



PILOT'S INFORMATION MANUAL

TB 10



TB10

from S/N 948

P/N : T00. 18430310E3

PILOT'S INFORMATION MANUAL

CAUTION

**THIS INFORMATION MANUAL IS A NON-OFFICIAL COPY OF THE PILOT'S
OPERATING HANDBOOK AND MAY BE USED FOR GENERAL INFORMATION
PURPOSES ONLY.**

**IT IS NOT KEPT CURRENT AND THEREFORE CANNOT BE USED AS A SUBSTITUTE
FOR AIRWORTHINESS AUTHORITIES APPROVED MANUAL WHICH IS THE ONLY ONE
INTENDED FOR OPERATION OF THE AIRPLANE.**

The content of this document is the property of SOCATA. It is supplied in confidence and commercial security of its contents must be maintained. It must not be used for any purpose other than that for which it is supplied, nor may information contained in it be disclosed to unauthorized persons. It must not be reproduced nor transmitted in any form in whole or in part without permission in writing from the owners of the Copyright.
Information in this document is subject to change without notice.

© 1989 to 2003 – SOCATA – All rights reserved

For any information concerning this document, please contact :

EADS SOCATA

**DIRECTION DES SERVICES
65921 TARBES CEDEX 9
FRANCE**

TELEPHONE : 33 (0)5.62.41.73.00

TELEFAX : 33 (0)5.62.41.76.54

September 30, 1989 – E3R7

Printed in FRANCE

TABLE OF CONTENTS

	SECTION
GENERAL	1
LIMITATIONS	2
EMERGENCY PROCEDURES	3
NORMAL PROCEDURES	4
PERFORMANCE	5
WEIGHT AND BALANCE	6
DESCRIPTION	7
AIRPLANE HANDLING, SERVICING AND MAINTENANCE	8
SUPPLEMENTS	9

SECTION 1

GENERAL

TABLE OF CONTENTS

	Page
THREE VIEW DRAWING	1.2
GENERAL	1.3
DESCRIPTIVE DATA	1.3
ENGINE	1.3
PROPELLER	1.3
FUEL	1.4
OIL	1.4
MAXIMUM CERTIFICATED WEIGHTS	1.5
AIRPLANE WEIGHTS	1.5
CABIN AND ENTRY DIMENSIONS	1.5
BAGGAGE SPACE AND ENTRY DIMENSIONS	1.5A
SYMBOLS, ABBREVIATIONS AND TERMINOLOGY	1.6
GENERAL AIRSPEED TERMINOLOGY AND SYMBOLS	1.6
METEOROLOGICAL TERMINOLOGY	1.7
ENGINE POWER TERMINOLOGY	1.7
AIRPLANE PERFORMANCE AND FLIGHT PLANNING TERMINOLOGY ..	1.7
WEIGHT AND BALANCE TERMINOLOGY	1.8
GENERAL ABBREVIATIONS	1.9
RADIO ABBREVIATIONS	1.11
CONVERSION FACTORS	1.12
STANDARD ATMOSPHERE	1.12
CONVERSION TABLE	1.13

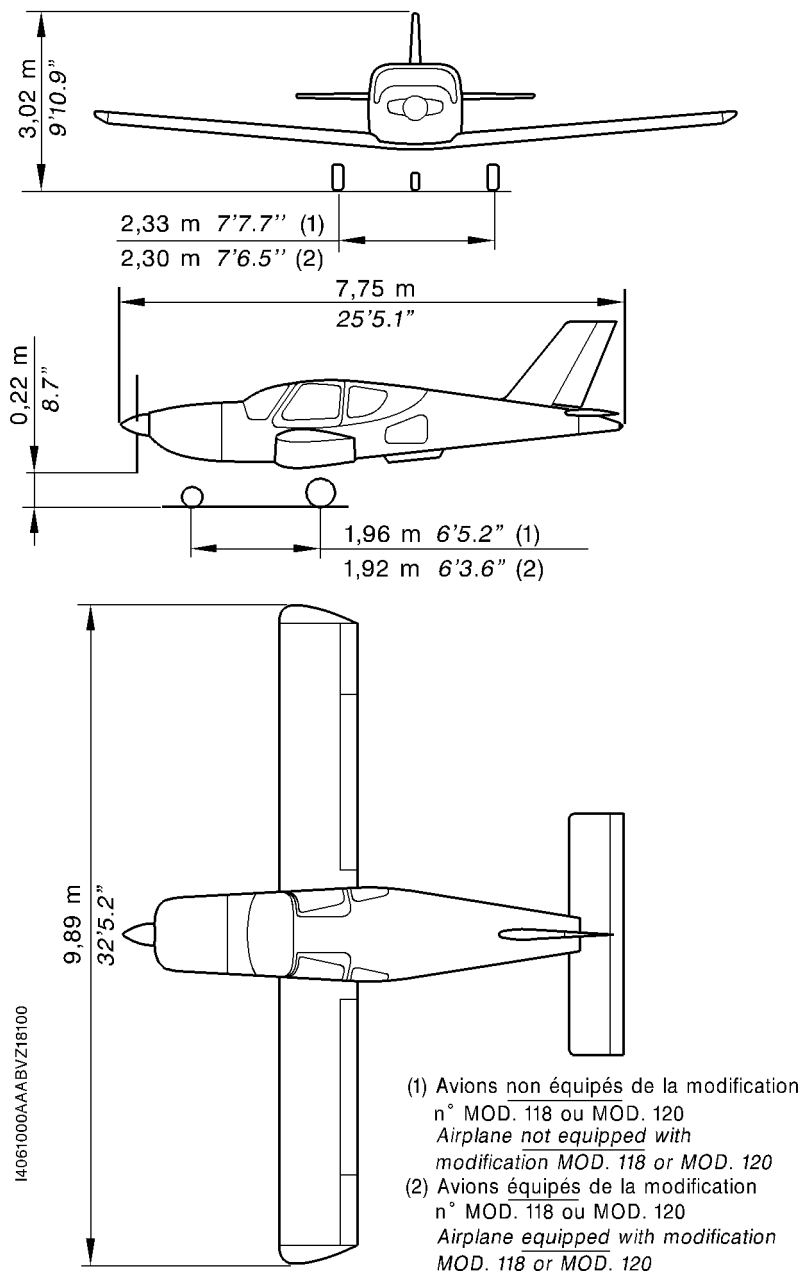

Figure 1.1 - THREE VIEW DRAWING

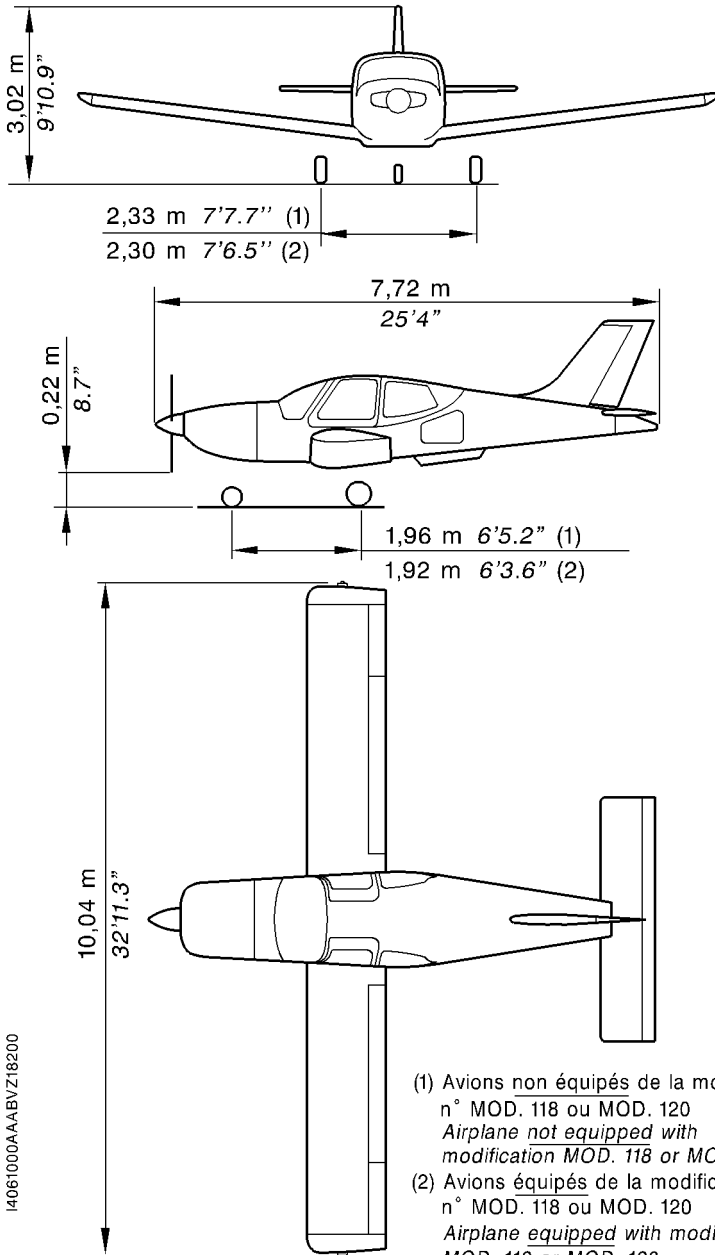

Figure 1.1A - THREE VIEW DRAWING

INTENTIONALLY LEFT BLANK

GENERAL

This handbook contains 9 sections, and includes the material required by FAR Part 23 to be furnished to the pilot for operation of SOCATA Model TB 10 airplane. It also contains supplemental data supplied by SOCATA.

This section provides basic data and information of general interest. It also contains definitions or explanations of abbreviations and terminology commonly used.

The general for optional systems are given in Section 9 "Supplements" of this Manual and any airplane/country specifics are given in Section "Specifics" hereto.

DESCRIPTIVE DATA

ENGINE

Number of engines : 1

Engine Manufacturer : AVCO LYCOMING

Engine Model Number : O-360-A1AD

Engine Type :

Four-cylinder, horizontally opposed, direct drive, air-cooled

Engine rated at 180 BHP at 2700 RPM.

PROPELLER

Number of propellers : 1

Propeller Manufacturer : HARTZELL

Propeller Model Number : HC-C2YK-1BF/F7666A-2

Number of blades : 2

Propeller Diameter :

Maximum : 74 inches (1.88 m)

Minimum : 72 inches (1.83 m)

Propeller Type :

Constant-speed, hydraulically-actuated

Propeller Governor : HARTZELL F4

FUEL

Approved Fuel Grades (and Colors) :

100 LL Grade Aviation Fuel (Blue)

100 (Formerly 100/130) Grade Aviation Fuel (Green)

Total capacity : 55.4 U.S Gallons (210 Litres)

Total capacity each tank : 27.7 U.S Gallons (105 Litres)

Total usable : 53.8 U.S Gallons (204 Litres)

NOTE :

Isopropyl alcohol or ethylene glycol monomethyl ether may be added to the fuel supply. Additive concentrations shall not exceed 1 % for isopropyl alcohol or 0.15 % for ethylene glycol monomethyl ether. Refer to Section 8 "Handling, servicing and maintenance" for additional information.

OIL

CAUTION

DO NOT MIX DIFFERENT BRANDS OR TYPES OF OIL

Oil grades (specifications) and Viscosity (Reference : TEXTRON LYCOMING Service Bulletin No. 480 at last revision) :

Outside Air Temperatures	MIL-L-6082 Spec. Mineral Grades 50 first hours	MIL-L-22851 Spec. Dispersant Grades after 50 hours
All temperatures	SAE 15W50 or SAE 20W50
Above 80°F (27°C)	SAE 60	SAE 60
Above 60°F (15°C)	SAE 50	SAE 40 or SAE 50
30°F (-1°C) to 90°F (32°C)	SAE 40	SAE 40
0°F (-18°C) to 70°F (21°C)	SAE 30	SAE 30, SAE 40 or SAE 20W40
0°F (-18°C) to 90°F (32°C)	SAE 20W50 or SAE 15W50
Below 10°F (-12°C)	SAE 20	SAE 30 or SAE 20W30

Oil Capacity :

Sump : 8 Quarts (7.6 Litres)

Total : 8.45 Quarts (8 Litres)

Maximum oil consumption : 0.8 qt/hr.

Do not operate on less than 4 U.S. qt (3.8 litres). To minimize loss of oil through breather, fill to 6 U.S. qt (5.7 litres) for normal flights of less than 3 hours. For extended flights, fill to 8 U.S. qt (7.6 litres). These quantities refer to oil dipstick level readings. During oil and filter changes 0.45 additional U.S. qt (0.4 litres) is required for the filter.

MAXIMUM CERTIFICATED WEIGHTS

	Normal category	Utility category
Take-off :	2535 lbs (1150 kg)	2359 lbs (1070 kg)
Landing :	2535 lbs (1150 kg)	2359 lbs (1070 kg)

Weight in Baggage Compartment : 143 lbs (65 kg) ; refer to Section 6 for cargo loading instructions.

AIRPLANE WEIGHTS

Refer to the Weight sheet included in the I.I.R. (Individual Inspection Record).

NOTE :

Maximum useful load of your airplane must be calculated according to the weight given on the Weight sheet.

CABIN AND ENTRY DIMENSIONS

	<u>Pre-MOD.151</u>	<u>Post-MOD.151</u>
Maximum Cabin Width :	4.20 ft (1.28 m)	4.20 ft (1.28 m)
Maximum Cabin Length :	8.30 ft (2.53 m)	8.30 ft (2.53 m)
Maximum Cabin Height :	3.67 ft (1.12 m)	3.94 ft (1.20 m)
Number of Cabin Entries :	2	2
Maximum Entry Width :	3.45 ft (1.05 m)	3.48 ft (1.06 m)
Minimum Entry Width :	2.62 ft (0.80 m)	2.82 ft (0.86 m)
Maximum Entry Height :	2.30 ft (0.70 m)	2.46 ft (0.75 m)

BAGGAGE SPACE AND ENTRY DIMENSIONS

	<u>Pre-MOD.151</u>	<u>Post-MOD.151</u>
Maximum Compartment Width :	4.10 ft (1.25 m)	4.10 ft (1.25 m)
Minimum Compartment Width :	3.45 ft (1.05 m)	3.45 ft (1.05 m)
Maximum Compartment Length :	2.95 ft (0.90 m)	2.95 ft (0.90 m)
Minimum Compartment Length :	2.20 ft (0.67 m)	2.20 ft (0.67 m)
Maximum Compartment Height :	2.03 ft (0.62 m)	2.03 ft (0.62 m)
Minimum Compartment Height :	1.35 ft (0.41 m)	1.35 ft (0.41 m)
Entry Width :	2.10 ft (0.64 m)	2.10 ft (0.64 m)
Entry Height :	1.44 ft (0.44 m)	1.80 ft (0.55 m)

INTENTIONALLY LEFT BLANK

SYMBOLS, ABBREVIATIONS AND TERMINOLOGY

GENERAL AIRSPEED TERMINOLOGY AND SYMBOLS

- KCAS** : ***Knots Calibrated Airspeed*** is indicated airspeed corrected for position and instrument error and expressed in knots. Knots calibrated airspeed is equal to KTAS in standard atmosphere at sea level.
- MPH CAS** : ***Miles per hour Calibrated Airspeed***
- KIAS** : ***Knots Indicated Airspeed*** is the speed shown on the airspeed indicator and expressed in knots.
- MPH IAS** : ***Miles per hour Indicated Airspeed***
- KTAS** : ***Knots True Airspeed*** is the airspeed expressed in knots relative to undisturbed air which is KCAS corrected for altitude, temperature and compressibility.
- V_A** : ***Maneuvering Speed*** is the maximum speed at which full or abrupt control movements may be used.
- V_{FE}** : ***Maximum Flap Extended Speed*** is the highest speed permissible with wing flaps in a prescribed extended position.
- V_{NE}** : ***Never Exceed Speed*** is the speed limit that may not be exceeded at any time.
- V_{NO}** : ***Maximum Structural Cruising Speed*** is the speed that should not be exceeded except in smooth air, and then only with caution.
- V_{SO}** : ***Stalling Speed or the minimum steady flight speed*** at which the airplane is controllable in the landing configuration.
- V_{S1}** : ***Stalling Speed or the minimum steady flight speed*** obtained in a specific configuration.

METEOROLOGICAL TERMINOLOGY

- ISA** : **International Standard Atmosphere** : Its temperature is 59°F (15°C) at sea level pressure altitude and decreases by 3.6°F (2°C) for each 1000 ft of altitude.
- OAT** : **Outside Air Temperature** is the free air static temperature. It is expressed in either degrees Celsius or degrees Fahrenheit.

Pressure Altitude :

Is the altitude read from an altimeter when the altimeter's barometric scale has been set to 29.92 inches of mercury (1013.2 hPa).

- QNH** : Setting at the pressure corresponding to the reading of actual airplane altitude

ENGINE POWER TERMINOLOGY

- BHP** : **Brake Horsepower** is the power developed by the engine.
- MP** : **Manifold Pressure** is a pressure measured in the engine's induction system and is expressed in inches of mercury (in.Hg).
- RPM** : **Revolutions Per Minute** is engine speed.

AIRPLANE PERFORMANCE AND FLIGHT PLANNING TERMINOLOGY

Climb Gradient :

Is the demonstrated ratio of the change in height during a portion of climb, to the horizontal distance traversed in the same time interval.

Demonstrated crosswind velocity :

Is the velocity of the crosswind component for which adequate control of the airplane during take-off and landing was actually demonstrated during certification tests. The value shown is not considered to be limiting.

- g** : Is acceleration due to gravity.

Unusable Fuel :

Fuel remaining after a runout test has been completed in accordance with governmental regulations.

WEIGHT AND BALANCE TERMINOLOGY

Reference Datum :

Is an imaginary vertical plane from which all horizontal distances are measured for balance purpose.

Arm : Is the horizontal distance from the reference datum to the center of gravity (C.G.) of an item.

Moment : Is the product of the weight of an item multiplied by its arm. (Moment divided by the constant 1000 is used in this handbook to simplify balance calculations by reducing the number of digits).

Center of gravity (C.G.) :

Is the point at which an airplane, or equipment, would balance if suspended. Its distance from the reference datum is found by dividing the total moment by the total weight of the airplane.

C.G. Limits : **Center of Gravity Limits** are the extreme center of gravity locations within which the airplane must be operated at a given weight.

Useful Load : Is the difference between take-off weight and the airplane empty weight.

Maximum Take-off Weight :

Is the maximum weight approved for the start of the take-off run.

Maximum Landing Weight :

Is the maximum weight approved for landing touch-down.

GENERAL ABBREVIATIONS

A	:	Ampere
ALT or ALTr	:	Alternator
ALTr FLD	:	Alternator field (energization)
A/P	:	Autopilot
BAT	:	Battery
C	:	Consumption
CHT	:	Cylinder head temperature
°C	:	Degree Celsius (Centigrade)
°F	:	Degree Fahrenheit
EGT	:	Exhaust gas temperature
EXC	:	Energization
F PRESS	:	Fuel pressure
ft	:	Foot (Feet)
ft/min	:	Feet per minute
HOR	:	Electric horizon
hPa	:	Hectopascal
hr	:	Hour
in	:	Inch
in.Hg	:	Inch of mercury
kg	:	Kilogram
kt	:	Knot (1 nautical mile/hr - 1852 m/hr)
l	:	Litre
lb	:	Pound
LDG	:	Landing gear
m	:	Metre
min	:	Minute
mm	:	Millimetre
P/N	:	Part Number
psi	:	Pounds per square inch
qt	:	Quart
QTY	:	Quantity
SM	:	Statute Mile
R.M. SWITCH	:	RADIO MASTER switch

GENERAL ABBREVIATIONS (Cont'd)

S/N : Serial Number
sq.ft : Square foot
Std : Standard
U.S Gal : U.S Gallon
V : Volt

RADIO ABBREVIATIONS

ADF	: Automatic Direction Finder System
ADI	: Attitude Director Indicator
ATC	: ATC transponder
COM	: Communications Transceivers
DME	: Distance Measuring Equipment
ELT	: Emergency Locator Transmitter
HF	: High Frequency
HSI	: Horizontal Situation Indicator
IFR	: Instrument Flight Rules
ILS	: Instrument Landing System
MKR	: Marker Radio Beacon
NAV	: Navigation Indicators and/or Receivers
RMI	: Radio Magnetic Indicator
UHF	: Ultra-High Frequency
VFR	: Visual Flight Rules
VHF	: Very High Frequency
VOR	: VHF Omnidirectional Range
VOR/LOC	: VHF Omnidirectional Range Localizer
VSI	: Vertical Speed Indicator
XPDR	: Transponder

CONVERSION FACTORS

IMPERIAL AND U.S. UNITS TO METRIC UNITS			METRIC UNITS TO IMPERIAL AND U.S. UNITS		
MULTIPLY	BY	TO OBTAIN	MULTIPLY	BY	TO OBTAIN
FEET	0.3048	METRE	METRE	3.2808	FEET
INCH	25.4	mm	mm	0.03937	INCH
Imp. Gal	4.546	Litre	Litre	0.220	Imp. Gal
U.S Gal	3.785	Litre	Litre	0.264	U.S Gal
lb	0.45359	kg	kg	2.2046	lb

STANDARD ATMOSPHERE

Pressure altitude (ft)	Pressure (hPa)	°C	°F
0	1013.2	+ 15.0	+ 59.0
2000	942.1	+ 11.0	+ 51.8
4000	875.0	+ 7.0	+ 44.6
6000	811.9	+ 3.1	+ 37.6
8000	752.6	- 0.8	+ 30.5
10000	696.8	- 4.8	+ 23.4
12000	644.3	- 8.7	+ 16.2
14000	595.2	- 12.7	+ 9.2
16000	549.1	- 16.6	+ 2.2
18000	505.9	- 20.6	- 5.0
20000	465.6	- 24.6	- 12.4

CONVERSION TABLE

NOTE :

The standard pressure of 1013.2 hPa is equal to 29.92 inches of mercury.

950 28.05	951 28.08	952 28.11	953 28.14	954 28.17	955 28.20	956 28.23	957 28.26	958 28.29	959 28.32
960 28.35	961 28.38	962 28.41	963 28.44	964 28.47	965 28.50	966 28.53	967 28.56	968 28.58	969 28.61
970 28.64	971 28.67	972 28.70	973 28.73	974 28.76	975 28.79	976 28.82	977 28.85	978 28.88	979 28.91
980 28.94	981 28.97	982 29.00	983 29.03	984 29.06	985 29.09	986 29.12	987 29.15	988 29.18	989 29.20
990 29.23	991 29.26	992 29.29	993 29.32	994 29.35	995 29.38	996 29.41	997 29.44	998 29.47	999 29.50
1000 29.53	1001 29.56	1002 29.59	1003 29.62	1004 29.65	1005 29.68	1006 29.71	1007 29.74	1008 29.77	1009 29.80
1010 29.83	1011 29.85	1012 29.88	1013 29.91	1014 29.94	1015 29.97	1016 30.00	1017 30.03	1018 30.06	1019 30.09
1020 30.12	1021 30.15	1022 30.18	1023 30.21	1024 30.24	1025 30.27	1026 30.30	1027 30.33	1028 30.36	1029 30.39
1030 30.42	1031 30.45	1032 30.47	1033 30.50	1034 30.53	1035 30.56	1036 30.59	1037 30.62	1038 30.65	1039 30.68
1040 30.71	1041 30.74	1042 30.77	1043 30.80	1044 30.83	1045 30.86	1046 30.89	1047 30.92	1048 30.95	1049 30.98

INTENTIONALLY LEFT BLANK

SECTION 2

LIMITATIONS

TABLE OF CONTENTS

	Page
GENERAL	2.3
AIRSPPEED LIMITATIONS	2.4
AIRSPPEED INDICATOR OR TRUE AIRSPPEED INDICATOR MARKINGS	2.5
POWER PLANT LIMITATIONS	2.6
STARTER OPERATION LIMITS	2.7
POWER PLANT INSTRUMENT MARKINGS	2.8
WEIGHT LIMITS	2.10
CENTER OF GRAVITY LIMITS	2.10
MANEUVER LIMITS	2.11
DESIGN LIMIT LOAD FACTORS	2.11
KINDS OF OPERATION LIMITS	2.12
FUEL LIMITATIONS	2.12
CREW LIMITATIONS	2.12
SEATING LIMITS	2.12
USE OF DOORS	2.13
VACUUM GAGE MARKINGS	2.13
PLACARDS	2.14

INTENTIONALLY LEFT BLANK

GENERAL

SOCATA Model TB 10 is certificated in the Normal and Utility Categories.

- Basic general technical conditions :
FAR 23 Regulations, amendments 1 to 16.

This airplane must be flown in compliance with the limits specified by placards or markings and with those given in this section and throughout this Manual.

This section of the airplane Pilot's Operating Handbook presents the various operating limitations, the significance of such limitations, instrument markings, color coding, and basic placards necessary for the safe operation of the airplane, its power plant and installed equipment.

The limitations for optional systems are given in Section 9 "Supplements" of this Manual and any airplane/country specifics are given in Section "Specifics" hereto.

AIRSPEED LIMITATIONS

Airspeed limitations and their operational significance are shown in Figure 2.1.

	SPEED	KCAS	KIAS	REMARKS
V_{NE}	Never Exceed Speed	165	165	Do not exceed this speed in any operation
V_{NO}	Maximal Structural Cruising Speed	128	128	Do not exceed this speed except in smooth air, and then only with care
V_A	Maneuvering Speed	122	122	Do not make abrupt or full control movements above this speed
V_{FE}	Maximum Flap Extended Speed	95	95	Do not exceed this speed with flaps extended

Figure 2.1 - AIRSPEED LIMITATIONS

AIRSPEED INDICATOR OR TRUE AIRSPEED INDICATOR MARKINGS

Airspeed indicator or true airspeed indicator markings and their color code significance are shown in Figure 2.2.

MARKING	KIAS VALUE OR RANGE	SIGNIFICANCE
White Arc	53 - 95	Full Flap Operating Range Lower limit is maximum weight V_{SO} in landing configuration. Upper limit is maximum speed permissible with flaps extended
Green Arc	60 - 128	Normal Operating Range Lower limit is maximum weight V_{S1} with flaps retracted. Upper limit is maximum structural cruising speed
Yellow Arc	128 - 165	Operations must be conducted with caution and only in smooth air
Red line	165	Maximum speed for all operations

Figure 2.2 - AIRSPEED INDICATOR OR TRUE AIRSPEED INDICATOR MARKINGS

POWER PLANT LIMITATIONS

Number of engines : 1

Engine Manufacturer : AVCO LYCOMING

Engine Model Number : O-360-A1AD

Engine Operating Limits for Take-off and Continuous Operations :

Maximum Power : 180 BHP

Maximum Engine Speed : 2700 RPM

Maximum Cylinder Head Temperature : 500°F (260°C)

Maximum Oil Temperature : 244°F (118°C)

Oil Pressure :

Minimum : 25 psi (1.7 bar)

Maximum : 115 psi (7.9 bars)

Fuel Pressure :

Minimum : 0.5 psi (34 hPa)

Fuel Grades : See Fuel Limitations

Oil Grades (Specification) :

MIL-L-6082 Aviation Grade Mineral Oil or

MIL-L-22851 Aviation Grade Dispersant Oil

Number of propellers : 1

Propeller Manufacturer : HARTZELL

Propeller Model Number : HC-C2YK-1BF/F7666A-2

Propeller Diameter :

Minimum : 72 inches (1.83 m)

Maximum : 74 inches (1.88 m)

Propeller Operating Limits :

Restricted Range for Continuous Operation : 2000 to 2250 RPM

STARTER OPERATION LIMITS

Starter operation sequence is limited to 10 seconds.

Should several sequences be necessary, respect following spacing :

1st sequence

wait 1 minute

2nd sequence

wait 1 minute

3rd sequence

wait 15 minutes

4th sequence

POWER PLANT INSTRUMENT MARKINGS

Power plant instrument markings and their color code significance are shown in Figure 2.3.

INSTRUMENT	Red Line or Arc ----- Minimum Limit	Yellow arc Red arc ----- Caution Range	Y R --- /	Green Arc ----- Normal Operating	Red Line or Arc ----- Maximum Limit
Tachometer	---	2000 to 2250 RPM	R	750 to 2000 RPM and 2250 to 2700 RPM	2700 RPM
Oil Temperature	---	Below 104°F (40°C)	Y	104 to 244°F (40 to 118°C)	244°F (118°C)
Fuel Pressure (1)	Below 0.5 psi	---	/	Above 0.5 psi	---
Fuel Pressure (2)	Below 0.5 psi	---	/	0.5 to 8 psi	Above 8 psi
Oil Pressure (1)	25 psi	25 to 60 psi and 90 to 100 psi	Y	60 to 90 psi	100 psi
Oil Pressure (2)	25 psi	25 to 55 psi and 95 to 115 psi	Y	55 to 95 psi	115 psi
Cylinder head temperature (3)	---	435 to 500°F (224 to 260°C) (4)	Y	200 to 435°F (93 to 224°C) (4)	500°F (260°C)
Carburated air temperature (3)	---	14 to 41°F (-10 to +5°C)	Y	---	---

(1) Alternative No. 1 Pre-MOD.87

(2) Alternative No. 2 Post-MOD.87 (Engine monito. cluster "PEINTATEC")

(3) If installed on airplane

(4) Optional marking (according to instrument model)

Figure 2.3 - POWER PLANT INSTRUMENT MARKINGS

POWER PLANT INSTRUMENT MARKINGS

Power plant instrument markings and their color code significance are shown in Figures 2.3A and 2.3B.

INSTRUMENT	Red Line or arc ----- Minimum Limit	Yellow arc Red arc ----- Caution Range	Y R --- / ---	Green Arc ----- Normal Operating	Red Line or arc ----- Maximum Limit
Tachometer	---	2000 to 2250 RPM	R	750 to 2000 RPM and 2250 to 2700 RPM	2700 RPM
Oil Temperature	---	Below 104°F (40°C)	Y	104 to 244°F (40 to 118°C)	244°F (118°C)
Oil Pressure	25 psi	25 to 55 psi and 95 to 115 psi	Y	55 to 95 psi	115 psi
Cylinder head temperature (1)	---	435 to 500°F (224 to 260°C) (2)	Y	200 to 435°F (93 to 224°C) (2)	500°F (260°C)
Carburated air temperature (1)	---	14 to 41°F (-10 to +5°C)	Y	---	---

(1) If installed on airplane

(2) Optional marking (according to instrument model)

Figure 2.3A - POWER PLANT INSTRUMENT MARKINGS

INSTRUMENT	Minimum Limit : Illuminated warning light	Normal Operating	Maximum Limit : Illuminated warning light
Fuel Pressure	Below 0.5 psi	0.5 to 8 psi	Above 8 psi

Figure 2.3B - POWER PLANT INSTRUMENT MARKINGS

WEIGHT LIMITS

Normal category

Maximum Take-off Weight : 2535 lbs (1150 kg)

Maximum Landing Weight : 2535 lbs (1150 kg)

Utility category

Maximum Take-off Weight : 2359 lbs (1070 kg)

Maximum Landing Weight : 2359 lbs (1070 kg)

Maximum Weight in Baggage Compartment for both categories : 143 lbs (65 kg) ; refer to Section 6 for cargo loading.

CENTER OF GRAVITY LIMITS

Normal category

Forward :

42.6 inches (1.083 m) aft of datum at 2535 lbs (1150 kg)

39.8 inches (1.010 m) aft of datum at 2359 lbs (1070 kg)

37.3 inches (0.949 m) aft of datum at 2138 lbs (970 kg) or less.

Utility category

Forward :

40.7 inches (1.035 m) aft of datum at 2359 lbs (1070 kg)

38.3 inches (0.974 m) aft of datum at 2249 lbs (1020 kg)

37.3 inches (0.949 m) aft of datum at 2138 lbs (970 kg) or less.

Aft :

47.4 inches (1.205 m) aft of datum at all weights and for both categories.

Reference datum : Front face of firewall.

Straight line variation between points.

Leveling point : Upper fuselage spar

NOTE :

It is the responsibility of the pilot to ensure that the airplane is properly loaded.

See Section 6 "Weight and Balance" for proper loading instructions.

MANEUVER LIMITS

This airplane is certificated in both normal and utility categories.

Normal category

The normal category is applicable to airplane intended for non-aerobatic operations.

These include any maneuvers incidental to normal flying, stalls (except whip stalls) and turns in which the angle of bank is no more than 60°.

Maximum Design Weight	2535 lbs (1150 kg)
Design Maneuvering Speed	122 KIAS (141 MPH IAS)

The TB 10 airplane is approved for the following normal category maneuvers : Lazy eights, chandelles, and steep turns in which the angle of bank is not more than 60°.

Utility category

This airplane is not designed for aerobatic flight. However, the utility category is applicable to airplane intended for limited aerobatic operations.

Maximum Design Weight	2359 lbs (1070 kg)
Design Maneuvering Speed	122 KIAS (141 MPH IAS)

No aerobatic maneuvers are approved except those listed below :

Maneuver	Recommended Entry Speed
Chandelles	135 KIAS (155 MPH IAS)
Lazy eights	130 KIAS (149 MPH IAS)
Steep turns	108 KIAS (124 MPH IAS)
Stalls (except whip stalls)	Slow Deceleration

Spins Prohibited

DESIGN LIMIT LOAD FACTORS

	Normal category	Utility category
Flaps up :	+ 3.8 g and - 1.5 g	+ 4.4 g and - 1.8 g
Flaps down :	+ 2.0 g and 0	+ 2.0 g and 0

CAUTION

INTENTIONAL NEGATIVE LOAD FACTORS ARE PROHIBITED

KINDS OF OPERATION LIMITS

The airplane is equipped for day VFR operations and may be equipped for night VFR and day & night IFR operations. See Supplements Section of this Manual.

Flight into known icing conditions is prohibited.

FUEL LIMITATIONS

2 Tanks :	27.7 U.S Gallons	(105 Litres) each
Total Fuel :	55.4 U.S Gallons	(210 Litres)
Usable Fuel :	53.8 U.S Gallons	(204 Litres)
Unusable Fuel :	1.6 U.S Gallons	(6 Litres)

NOTE :

Usable fuel (up to unusable fuel) can be safely used during all normal airplane maneuvers.

FOR STEEP NOSE DOWN ATTITUDE (rapid descent) select a fuel tank with at least 7 U.S Gallons (a quarter of tank capacity).

FOR PRONOUNCED OR LONG SIDE SLIPPING select the fuel tank (with usable fuel) at the opposite side of the low wing.

CREW LIMITATIONS

Minimum crew : 1 pilot
(1 pilot required at L.H. station)

SEATING LIMITS

Front seats :2

Rear seats : 2 when accommodated with 2 seat belts or
3 when accommodated with 3 seat belts
[maximum total weight on rear seats :
454 lbs (206 kg)]

USE OF DOORS

Flight with doors open or ajar is prohibited.

VACUUM GAGE MARKINGS (if installed)

MARKING	CORRESPONDING VALUE
Green	Normal operating from 4.4 to 5.2 in.Hg
Red lines	at 4.4 and 5.2 in.Hg

PLACARDS

NOTE :

The placards described in the Section 9 "Supplements" replace or supplement those described in this paragraph.

- (1) In full view of the pilot, forward of overhead lights

Placards in lbs :

THIS AIRPLANE MUST BE OPERATED AS A NORMAL AND UTILITY CATEGORIES AIRPLANE IN COMPLIANCE WITH THE OPERATING LIMITATIONS STATED IN THE FORM OF PLACARDS, MARKINGS AND MANUALS.

INVERTED FLIGHT	PROHIBITED
ACROBATIC MANEUVERS IN NORMAL CATEGORY	PROHIBITED
INTENTIONAL SPINS	PROHIBITED
ICING CONDITIONS	PROHIBITED

NORMAL CATEGORY

MAXIMUM TAKE-OFF AND LANDING WEIGHT	2535 lbs
MANEUVERING SPEED V_A	122 KIAS
NEVER EXCEED SPEED V_{NE}	165 KIAS
FLAP EXTENDED SPEED V_{FE}	95 KIAS
DESIGN LIMIT LOAD FACTOR	FLAPS RETRACTED + 3.8
	FLAPS EXTENDED + 2

UTILITY CATEGORY

MAXIMUM TAKE-OFF AND LANDING WEIGHT	2359 lbs
MANEUVERING SPEED V_A	122 KIAS
NEVER EXCEED SPEED V_{NE}	165 KIAS
FLAP EXTENDED SPEED V_{FE}	95 KIAS
DESIGN LIMIT LOAD FACTOR	FLAPS RETRACTED + 4.4
	FLAPS EXTENDED + 2

ENTRY SPEED

CHANDELLES	135 KIAS
LAZY EIGHT	130 KIAS
STEEP TURN	108 KIAS
STALLS	

Placard in kg :

THIS AIRPLANE MUST BE OPERATED AS A NORMAL AND UTILITY CATEGORIES AIRPLANE IN COMPLIANCE WITH THE OPERATING LIMITATIONS STATED IN THE FORM OF PLACARDS, MARKINGS AND MANUALS.

INVERTED FLIGHT	PROHIBITED
ACROBATIC MANEUVERS IN NORMAL CATEGORY	PROHIBITED
INTENTIONAL SPINS	PROHIBITED
ICING CONDITIONS	PROHIBITED

NORMAL CATEGORY

MAXIMUM TAKE-OFF AND LANDING WEIGHT	1150 kg
MANEUVERING SPEED V_A	122 KIAS
NEVER EXCEED SPEED V_{NE}	165 KIAS
FLAP EXTENDED SPEED V_{FE}	95 KIAS
DESIGN LIMIT LOAD FACTOR	FLAPS RETRACTED + 3.8
	FLAPS EXTENDED + 2

UTILITY CATEGORY

MAXIMUM TAKE-OFF AND LANDING WEIGHT	1150 kg
MANEUVERING SPEED V_A	122 KIAS
NEVER EXCEED SPEED V_{NE}	165 KIAS
FLAP EXTENDED SPEED V_{FE}	95 KIAS
DESIGN LIMIT LOAD FACTOR	FLAPS RETRACTED + 4.4
	FLAPS EXTENDED + 2

ENTRY SPEED

CHANDELLES	135 KIAS
LAZY EIGHT	130 KIAS
STEEP TURN	108 KIAS
STALLS	

FLIGHT CONDITIONS : DAY VFR
ICING CONDITIONS NOT ALLOWED

(2) Calibration chart on compass

I4113003AAADVZ8000A

For	N	30	60	E	120	150
Steer						
For	S	210	240	W	300	330
Steer						

DATE: _____ RADIO ON _____

(3) On Baggage door

I4113006AAADVZ8000A

65 kg - 143 lbs MAXIMUM
FOR LOADING INSTRUCTIONS
SEE "WEIGHT AND BALANCE
DATA" IN FLIGHT MANUAL

(4) Near fuel tank caps

I4112500AAAANWZ8200

CARBURANT
FUEL - KRAFTSTOFF

AVGAS 100 LL

26.⁹US _ 22.⁴UK. GAL

102 L

(5) On the back side of access door to oil filler cap

I4112102AAAABVZ8100

Oil system
capacity
8 l
8.4 qt

(6) On the fuel selector

Markings in U.S. Gallons :

I4113004AAAATVZ18300

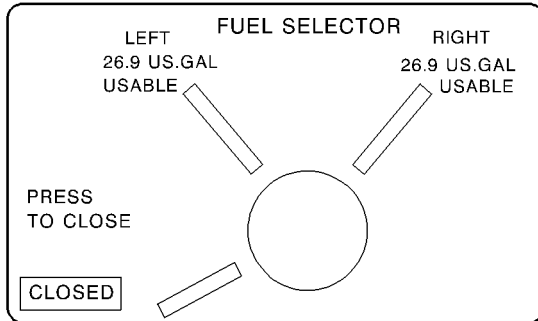

Markings in Litres :

I4113004AAAATVZ18100

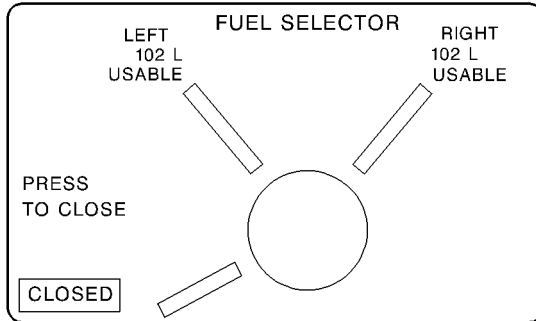

(7) Near the wing flap control

I4113004AAAEVZ8000A

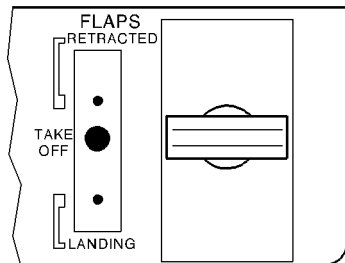

(8) Near the stabilator tab position indicator

I4113004AAA FVZ8201

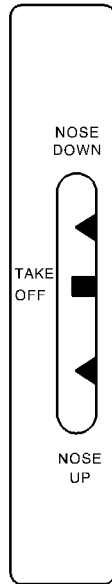

(9) If three belts are installed at the rear seats :

I4113002AAA AYZ8001

MASSE MAXI POUR 3 PASSAGERS AUX PLACES AR.	} 206 Kg
MAX GEWICHT FÜR 3 PASSAGIERE AUF DEM RÜCKSITZ	
MAX WEIGHT FOR 3 PASSENGERS ON REAR SEATS	

SECTION 3

EMERGENCY PROCEDURES

TABLE OF CONTENTS

	Page
GENERAL	3.3
AIRSPEDS FOR SAFE OPERATIONS (IAS)	3.3
ENGINE FAILURES	3.3
ENGINE FAILURE DURING TAKE-OFF RUN	3.3
ENGINE FAILURE IMMEDIATELY AFTER TAKE-OFF	3.4
ENGINE FAILURE IN FLIGHT	3.4
LOW OIL PRESSURE	3.5
LOW FUEL FLOW	3.5
ENGINE VIBRATION	3.5
PROPELLER GOVERNOR FAILURE	3.5
FORCED LANDINGS	3.6
EMERGENCY LANDING WITHOUT ENGINE POWER	3.6
PRECAUTIONARY LANDING WITH ENGINE POWER	3.6
DITCHING	3.7
FIRES	3.7
ENGINE FIRE DURING START	3.7
ENGINE FIRE IN FLIGHT	3.8
ELECTRICAL FIRE IN FLIGHT	3.8
CABIN FIRE	3.9
WING FIRE	3.9

TABLE OF CONTENTS
(Continued)

	Page
ICING	3.10
LANDING WITHOUT STABILATOR CONTROL	3.11
RADIO MASTER SWITCH FAILURE	3.11
AILERON CONTROL FAILURE	3.11
ELECTRICAL FAILURE : IMMEDIATE ACTION	3.12
ELECTRICAL EQUIPMENT FAILURE	3.12
ALTERNATOR FAILURE	3.12
ELECTRICAL FAILURE : CHECK-OUT PROCEDURE FOR NIGHT VFR AND IFR	3.13
ALTERNATOR FAILURE	3.13
BATTERY FAILURE	3.13
TOTAL ELECTRICAL FAILURE	3.13
AIRSPPEED INDICATING SYSTEM FAILURE	3.17
LANDING WITHOUT FLAPS	3.17
INVOLUNTARY SPIN	3.18
JAMMED DOORS	3.18
OPTIMUM GLIDE WITHOUT ENGINE RUNNING	3.19

GENERAL

This section provides the pilot with procedures that enable him to cope with emergencies that may be encountered in operating the SOCATA Model TB 10 airplane. If proper preflight inspections, operating procedures, and maintenance practices are used, emergencies due to airplane or engine malfunction should be rare. Likewise, careful flight planning and good pilot judgment can minimize enroute weather emergencies. However, should any emergency develop, the guidelines in this section should be considered and applied as necessary to correct the problem.

The emergency procedures for optional systems are given in Section 9 "Supplements" of this Manual and any airplane/country specifics are given in Section "Specifics" hereto.

AIRSPEEDS FOR SAFE OPERATIONS (IAS)

Engine failure after take-off	70 KIAS
Maneuvering speed	122 KIAS
Best glide speed	86 KIAS
Precautionary landing with engine power	65 / 70 KIAS

ENGINE FAILURES

ENGINE FAILURE DURING TAKE-OFF RUN

Throttle	REDUCED
Brakes	APPLY
Mixture	IDLE CUT-OFF
Magneto selector	OFF
Main switch	OFF
Fuel selector	OFF

ENGINE FAILURE IMMEDIATELY AFTER TAKE-OFF

Airspeed	70 KIAS
Mixture	FULL RICH
Fuel selector	SWITCH TANKS
Fuel pump	ON

If the engine does not start :

Mixture	IDLE CUT-OFF
Fuel selector	OFF
Fuel pump	OFF
Land	STRAIGHT AHEAD
Magneto selector	OFF
Main switch	OFF

WARNING

LANDING STRAIGHT AHEAD IS USUALLY ADVISABLE

ENGINE FAILURE IN FLIGHT

Glide speed	86 KIAS
Fuel pump	ON

If the engine does not start :

Mixture	IDLE CUT-OFF
Throttle	1/2 OPEN
Fuel gages	CHECK
Fuel selector	SWITCH TANKS
Magneto selector	BOTH
Starter	ENGAGE (if propeller stopped)
When the engine runs (windmilling)	SLOWLY ENRICH UNTIL RE-START

NOTE :

Engine re-starting can be performed without particular limitations in all airplane flight envelope.

If the engine does not start, get ready for an emergency landing without engine power.

NOTE :

Gliding distance - see Figure 3.4.

LOW OIL PRESSURE

Oil warning light	ON
Pressure indicator	IN RED LOW SECTOR
Throttle	REDUCE AS FAR AS POSSIBLE
Oil temperature	CHECKED
If oil temperature in red sector	REDUCE THROTTLE

Prepare for a forced landing and land as soon as possible.

LOW FUEL FLOW

Fuel pump	OPERATING
Fuel gages	CHECKED
Fuel selector	SWITCH TANKS

ENGINE VIBRATION

Engine vibration is generally due to carburetor icing (see § "Icing"), defective spark plugs or too rich a mixture.

Mixture	RESET
---------	-------

If vibration persist :

RPM	SET FOR MINIMUM VIBRATION RANGE
-----	---------------------------------

Land as soon as possible.

PROPELLER GOVERNOR FAILURE

In case of oil pressure drop in the governor system or pitch control failure, the propeller moves to low pitch.

Oil pressure	CHECKED
Oil temperature	CHECKED
Throttle	AS REQUIRED
Airspeed	REDUCED

Avoid rapid application of power.

CAUTION : MAXIMUM RPM : 2700

FORCED LANDINGS

EMERGENCY LANDING WITHOUT ENGINE POWER

Glide speed 86 KIAS
Radio TRANSMIT MAYDAY on 121.5 MHz
or on the appropriate frequency
giving location and intentions

Seats, seat belts,
shoulder harnesses ADJUSTED and SECURE
Mixture IDLE CUT-OFF
Fuel selector OFF
Magneto selector OFF
Flaps AS REQUIRED

When the landing is secured :

Flaps LANDING
Approach speed 65 / 70 KIAS
Main switch OFF

PRECAUTIONARY LANDING WITH ENGINE POWER

Flaps LANDING
Approach speed 65 / 70 KIAS
Radio ADVISE ATC OF INTENTIONS
Seats, seat belts,
shoulder harnesses ADJUSTED and SECURE
Field FLY OVER selected field
Main switch OFF
Touch-down FLARE OUT
and keep nose high
Mixture IDLE CUT-OFF
Fuel selector OFF
Magneto selector OFF
Brakes AS REQUIRED

DITCHING

Radio	TRANSMIT MAYDAY on 121.5 MHz or on the appropriate frequency giving location and intentions
Flaps	LANDING
Seats, seat belts, shoulder harnesses	ADJUSTED and SECURE
Airspeed	70 KIAS
Flight path	Parallel to swells
Before touch-down :	
■ Main switch	OFF
Magneto selector	OFF
Mixture	IDLE CUT-OFF
Fuel selector	OFF
Touch-down	FLARE OUT and keep nose high

FIRES

ENGINE FIRE DURING START

Mixture	IDLE CUT-OFF
Starter	GO ON STARTING
Throttle	FULL THROTTLE
Fuel selector	OFF
If fire goes on :	
Main switch	OFF
Magneto selector	OFF

Evacuate passengers and extinguish fire using all available means (fire extinguisher if installed).

ENGINE FIRE IN FLIGHT

Visual detection	SMOKE - FLAMES
Fuel selector	OFF
Mixture	IDLE CUT-OFF
Fuel pump	OFF
Throttle	FULL THROTTLE
Cabin air cooling & demisting	FIRE CUT-OFF (-)

After engine has stopped :

Magneto selector	OFF
"ALTr FLD" switch-breaker	OFF
Forced landing	EXECUTE (as described in "Emergency Landing without Engine Power")

WARNING

**NO ATTEMPT SHOULD BE MADE TO RESTART THE
ENGINE AFTER A FIRE**

ELECTRICAL FIRE IN FLIGHT

* *If FIRE is in ENGINE COMPARTMENT :*

Main switch	OFF
Cabin air cooling & demisting	FIRE CUT-OFF

Land as soon as possible.

* *If FIRE is in CABIN :*

Main switch	OFF
"ALTr FLD" switch-breaker	OFF
All electrical switches (except magnetos)	OFF
Cabin air cooling & demisting	FIRE CUT-OFF
Fire extinguisher (if installed)	ACTIVATE

* *If FIRE APPEARS TO BE OUT and electrical power is
necessary to continue flight :*

Main switch	ON
Circuit breakers	CHECK for faulty circuit do not close
Radio/electrical switches	ON, one at a time
Cabin air cooling	OPEN, when fire is out

CABIN FIRE

Main switch	OFF
Cabin air cooling & demisting	FIRE CUT-OFF
Fire extinguisher (if installed)	ACTIVATE

WARNING

**AFTER DISCHARGING A FIRE EXTINGUISHER
WITHIN A CLOSED CABIN, WHEN FIRE IS
EXTINGUISHED, PARTIALLY OPEN CABIN AIR
COOLING TO VENTILATE THE CABIN AND
PREVENT SUFFOCATION**

Land as soon as possible.

WING FIRE

Navigation and landing lights	OFF
Anticollision lights (if installed)	OFF
Pitot heat switch (if installed)	OFF

Land as soon as possible.

ICING

FLIGHT INTO KNOWN ICING CONDITIONS IS PROHIBITED

Carburetor icing leads to a power rating drop, a manifold pressure drop and slight vibration :

Carburetor heating ON

NOTE :

Pulling the carburetor heating control may cause the power rating to drop and increase the vibration level. After having pulled fully the carburetor heating control, it is mandatory to adjust the mixture to suppress vibration. The use of carburetor heating increases appreciably the hourly fuel consumption.

Cabin temperature FULL HOT

Pitot heating (if installed) ON

Demisting OPEN

Engine INCREASE POWER
and periodically change RPM to
minimize ice buildup on propeller

Carburated air thermometer
(if installed) + 41 to + 68°F (+ 5 to + 20°C)

Turn back or change altitude to obtain best outside air conditions.

After disappearing of icing conditions :

Carburetor heating OFF

If icing continues plan a landing at the nearest airport. With an extremely rapid ice build-up, select a suitable "off airport" landing site.

NOTE :

With an ice accumulation on or near the wing leading edges, a higher stalling speed may be expected. Plan all maneuvers accordingly.

LANDING WITHOUT STABILATOR CONTROL

Fly the airplane using pitch trim and throttle.

- *Long final* :

Airspeed	80 KIAS
Flaps	LANDING
Fuel pump	ON
Mixture	FULL RICH
Propeller	HIGH RPM
Throttle and pitch trim	ADJUST SO AS TO MAINTAIN A RATE OF DESCENT LOWER THAN 500 ft/min

- *Final* :

FLARE OUT near the ground with the pitch trim.

CAUTION

**REDUCE THROTTLE ONLY
AFTER TOUCH-DOWN**

RADIO MASTER SWITCH FAILURE (if installed)

When radio navigation equipment cannot be set under voltage due to RADIO MASTER switch malfunction :

“R.M. SWITCH” circuit breaker OPEN

Radionavigation equipment are supplied again and flight can go on normally.

AILERON CONTROL FAILURE

Should an aileron control efficiency loss occur (accidental disconnection), fly the airplane using rudder for lateral control.

If flaps are extended, set rapidly sufficient speed (70 KIAS at least) and retract flaps.

Land with retracted flaps at 80 KIAS.

ELECTRICAL FAILURE : IMMEDIATE ACTION

ELECTRICAL EQUIPMENT FAILURE

Check the circuit breakers panel.

If the circuit breaker is tripped, close it once only.

If it trips again, do not try to close the circuit breaker, the equipment has failed.

ALTERNATOR FAILURE (SIMPLIFIED PROCEDURE)

“ALTr” warning light (low voltage) ON

Pre-MOD.182

Voltmeter :

- Green sector CONTINUE FLYING

- Red/yellow sector :

“ALTr FLD” switch-breaker OFF then ON

Post-MOD.182

Voltmeter :

- $26 < V < 29$ CONTINUE FLYING

- < 26 :

“ALTr FLD” switch-breaker OFF then ON

All

“ALTr” warning light REMAINS ON

“ALTr FLD” switch-breaker OFF

Nonessential electrical load items OFF

CAUTION

**SEE HEREAFTER CHECK-OUT PROCEDURE FOR
NIGHT VFR OR IFR (see Figure 3.1)**

CAUTION

**CHECK BATTERY DISCHARGE IN THIS CASE,
ENDURANCE IS REDUCED AS ELECTRICAL
POWER IS ONLY SUPPLIED BY BATTERY**

Battery approximate duration : 40 min (Night IFR emergency conditions).

ELECTRICAL FAILURE : CHECK-OUT PROCEDURE FOR NIGHT VFR AND IFR

ALTERNATOR FAILURE (See Figure 3.1)

BATTERY FAILURE (See Figure 3.2)

TOTAL ELECTRICAL FAILURE (See Figure 3.3)

KEY: CB : Circuit breaker
PCB : Pull-off type circuit breaker
SB : Switch-breaker

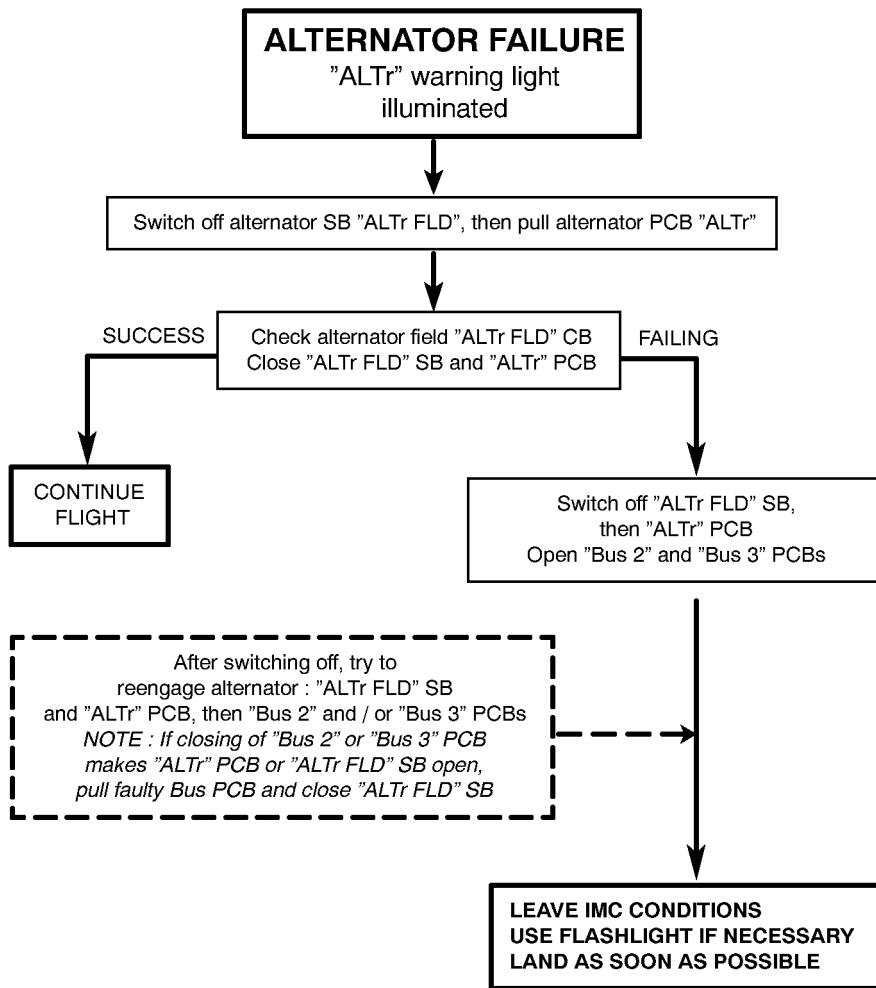

Figure 3.1 - ALTERNATOR FAILURE DIAGRAM

KEY: PCB : Pull-off type circuit breaker
SB : Switch-breaker

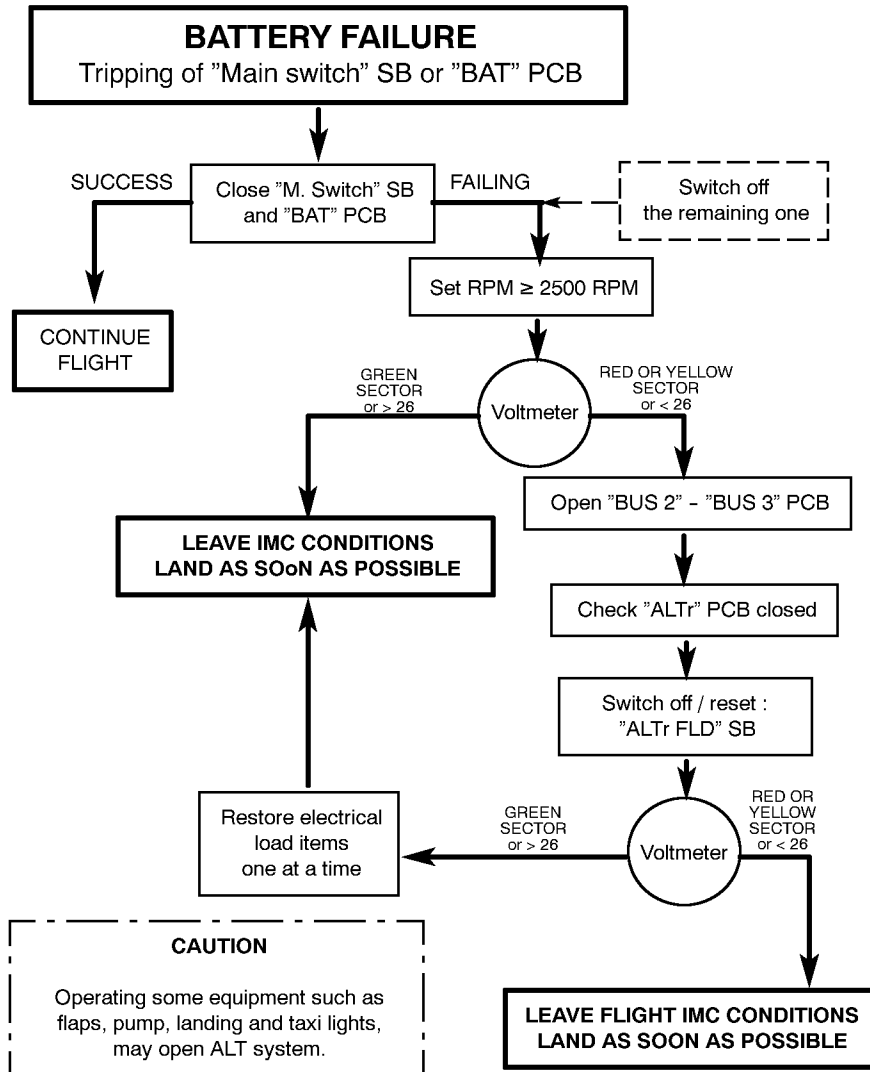

Figure 3.2 - BATTERY FAILURE DIAGRAM

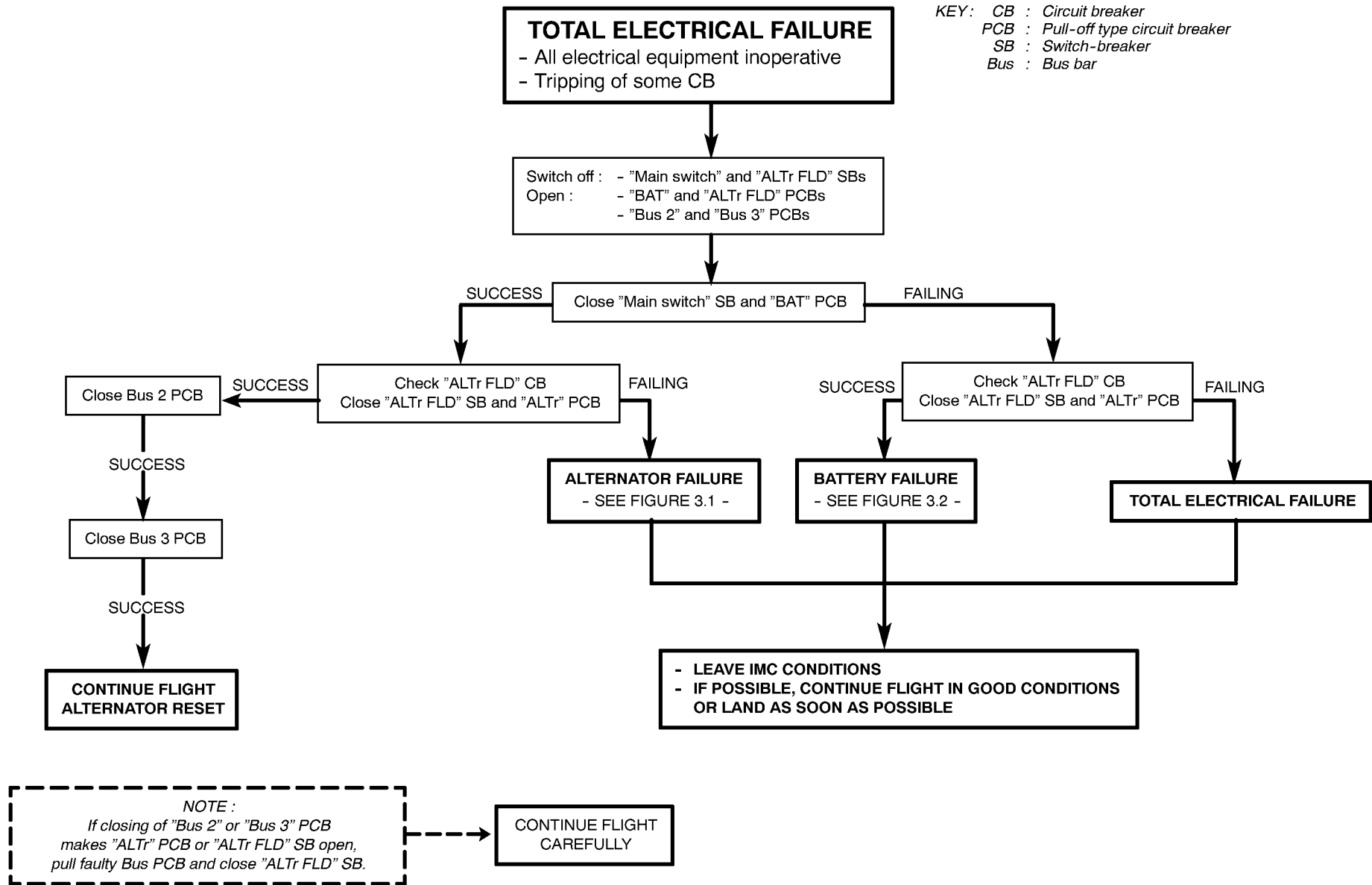

Figure 3.3 - TOTAL ELECTRICAL FAILURE DIAGRAM

AIRSPPEED INDICATING SYSTEM FAILURE

In case of erroneous indications in flight :

Pitot heating (if installed) ON

Alternate static source
(if installed) EMERGENCY (Pulled)

In case of alternate static source
utilization, open air outlets and/or actuate
cabin air selector flow lever to open
position. Then, airspeed indicator and
altimeter errors are not significant.

If erroneous indications persist, carry out a precautionary approach maintaining an adequate airspeed margin above stall warning activation speed.

Recommended parameters :

Propeller FULL FORWARD

Manifold pressure AS REQUIRED

(Approach : 15 in.Hg)

LANDING WITHOUT FLAPS (Flaps locked, retracted)

"FLAPS" circuit breaker OPEN

Flaps control ACTUATED

If the procedure is not successful, perform the same operations as for a normal landing and maintain a 80 KIAS approach speed.

Plan a landing distance increased by approximately 60 %.

For landing performance, refer to Section 5 "Performance".

INVOLUNTARY SPIN

INTENTIONAL SPINS ARE PROHIBITED

However, should inadvertent spin occur, the following recovery procedure is recommended :

Rapid and simultaneous action :

Throttle	REDUCED
Rudder control	HOLD OPPOSITE DIRECTION OF ROTATION
Stabilator control	FULL FORWARD
Ailerons	NEUTRAL

Spin with flaps :

Same procedure, except retract flaps as soon as possible.

When spinning stops, centralize rudders, level the wings and ease out of the ensuing dive.

JAMMED DOORS

Pre-MOD.151

In case of jammed doors and in case of emergency :
JETTISON REAR WINDOWS, kicking with foot on the upper part.

OPTIMUM GLIDE WITHOUT ENGINE RUNNING

- Speed 85 KIAS at maximum weight
- Propeller wind milling
- Flaps up
- Zero wind

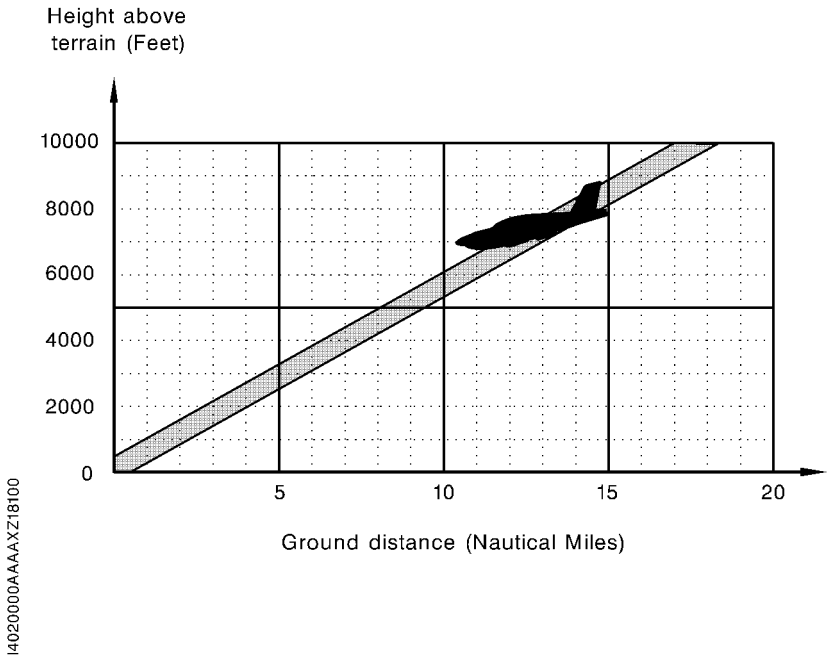

Figure 3.4 - OPTIMUM GLIDE WITHOUT ENGINE RUNNING

INTENTIONALLY LEFT BLANK

SECTION 4

NORMAL PROCEDURES

TABLE OF CONTENTS

	Page
GENERAL	4.3
AIRSPEEDS FOR SAFE OPERATIONS (IAS)	4.3
PREFLIGHT INSPECTIONS	4.5
AIRFRAME	4.5
ELECTRICAL SYSTEMS	4.8
BEFORE STARTING ENGINE	4.9
ENGINE STARTING	4.10
NORMAL PROCEDURE	4.10
HOT ENGINE PROCEDURE	4.10
COLD WEATHER PROCEDURE	4.11
FLOODED ENGINE PROCEDURE	4.12
AFTER STARTING ENGINE	4.13
TAXIING	4.13
ENGINE RUN-UP	4.14
BEFORE TAKE-OFF	4.15
TAKE-OFF	4.16
CLIMB	4.16
CRUISE	4.17
DESCENT	4.18
APPROACH - LANDING	4.18

TABLE OF CONTENTS
(Continued)

	Page
GO-AROUND	4.19
AFTER LANDING	4.19
SHUT-DOWN / SECURING AIRPLANE	4.20
PARTICULAR USES	4.21
STALLS	4.21
FLIGHT WITH CROSSWIND	4.21
FLIGHT IN TURBULENT AIR	4.22
USE OF DOORS	4.22

GENERAL

This section provides procedures for the conduct of normal operation of the SOCATA Model TB 10 airplane.

The normal procedures for optional systems are given in Section 9 "Supplements" of this Manual and any airplane/country specifics are given in Section "Specifics" hereto.

AIRSPEEDS FOR SAFE OPERATIONS (IAS)

Following speeds are those important for safe operation of airplane.

These data are valid for standard airplane used at maximum weight in normal conditions.

- Best rate of climb
 - . Flaps retracted 78 KIAS
 - . Flaps in landing position 70 KIAS
- Best angle of climb
 - . Flaps retracted 65 KIAS
 - . Flaps in landing position 58 KIAS
- Operating speed in turbulent air 122 KIAS
- Maximum speed with flaps in takeoff position 95 KIAS
- Maximum speed with flaps in landing position 95 KIAS
- Final approach speed (flaps in landing position) 72 KIAS
- Maximum demonstrated crosswind 25 kt

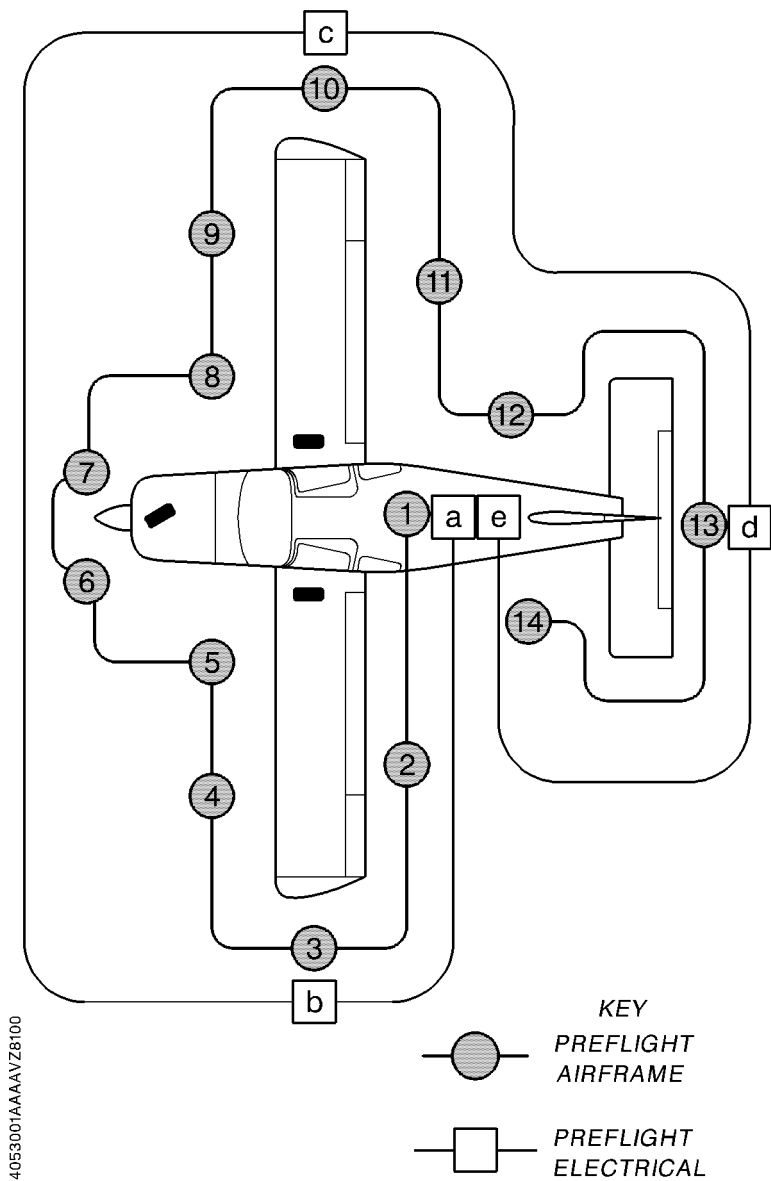

Figure 4.1 - PREFLIGHT INSPECTIONS

PREFLIGHT INSPECTIONS (See Figure 4.1)

AIRFRAME

1 - Cabin

Pilot door	OPEN
Control lock	REMOVED
Magneto selector	OFF
Mixture	IDLE CUT-OFF
Main switch	ON
Flaps	LANDING
Pitch trim	TAKE-OFF
Fire extinguisher	
(if installed)	Check pressure
Main switch	OFF
Fuel selector	OPEN (L.H.)

Proceed with the external preflight inspection moving clockwise around the airplane.

2 - L.H. wing trailing edge

Flap and aileron	Check controls, hinges, plays, deflections
------------------	---

3 - L.H. wing

Wing tip, lights and landing lights	Undamaged
--	-----------

4 - L.H. wing leading edge

Wing	Free from frost, snow, ice
Pitot	Cover removed, clean, unobstructed
Tie-down	REMOVED
Stall warning device	Clean, check deflection
Fuel tank	Check level
Fuel tank cap	SECURED
Fuel tank draining	Fuel free from water and sediment
Fuel tank drain	Check CLOSED

5 - L.H. main landing gear

Chocks	REMOVE
Tire	Check condition
Shock absorber	Normal position
Fairing	Check condition, cleanliness and normal position

6 - Forward fuselage

Windshield and window panels	Clean
Engine cowling attachment	Check
Oil	Check level and absence of leak
Propeller	Clean, good condition
Propeller cone	Check (no slack)
Air intakes	Clean
Oil pump breather	Unobstructed
Exhaust pipe	Check
Fuel filter draining	Fuel free from water and sediment
Fuel filter drain	Check CLOSED

7 - Nose landing gear

Towing fork	REMOVE
Tire	Check
Shock absorber	Normal position
Fairing	Check condition, cleanliness and normal position

8 - R.H. main landing gear

Chocks	REMOVE
Tire	Check condition
Shock absorber	Normal position
Fairing	Check condition, cleanliness and normal position

9 - R.H. wing leading edge

Fuel tank draining	Fuel free from water and sediment
Fuel tank drain	Check CLOSED
Fuel tank	Check level
Fuel tank cap	SECURED
Tie-down	REMOVED
Wing	Free from frost, snow and ice

10 - R.H. wing

Wing tip and lights	Undamaged
---------------------	-----------

11 - R.H. wing trailing edge

Flap and aileron	Check controls, hinges, plays, deflections
------------------	--

12 - R.H. rear fuselage

R.H. door lock	UNLOCKED
Static port	Cover removed, clean
Window panels	Clean

13 - Stabilizers

Fin	Check
Rudder	Check controls, hinges, plays, frictions
Stabilator and stabilator tab	Check controls, hinges, deflections, plays, frictions
Tail cone and navigation light <u>Pre-MOD.151</u>	Good condition

14 - L.H. rear fuselage

Static port	Cover removed, clean
Baggage compartment door	SECURED
Window panels	Clean

ELECTRICAL SYSTEMS

a - Cabin

“ALTr FLD” switch-breaker	OFF
Fuel pump	OFF
Main switch	ON
Engine monitoring cluster (<u>Post-MOD.182</u>)	Tested

NOTE :

Should the AMP lamp flash during test, contact your maintenance department as soon as possible (loss of one of the power supplies).

- V/A switch V

Advisory panel	Tested
Fuel gages	Check
Flaps	RETRACT
Instrument lights	ON
Navigation lights	ON
Anticollision lights (if installed)	ON
Strobe lights (if installed)	ON
Recognition lights (if installed) (<u>Post-MOD.151</u>)	ON
Pitot heating (if installed)	ON
Landing and taxi lights	ON

b - L.H. wing

Navigation light	Illuminated
Anticollision light (if installed)	Flashing
Recognition light (if installed) (<u>Post-MOD.151</u>)	Illuminated
Landing and taxi lights	Illuminated

WARNING

**DO NOT TOUCH PITOT DIRECTLY
 IT CAN BE HOT ENOUGH TO BURN SKIN**

Heated pitot (if installed)	Check heat
Stall warning device	Aural warning

NOTE :

Landing and taxi lights and Pitot heating “OFF” before carrying on inspection will prevent battery from being run down.

c - R.H. wing

Navigation light	Illuminated
Anticollision light (if installed)	Flashing
Recognition light (if installed) (<u>Post-MOD.151</u>)	Illuminated

d - Airplane rear part

Navigation light <u>Pre-MOD.151</u>	Illuminated
Strobe light (if installed)	Flashing
Anticollision light (if installed)	Flashing

e - Cabin

Navigation lights	OFF
Strobe lights (if installed)	OFF
Anticollision lights (if installed)	OFF
Recognition lights (if installed) (<u>Post-MOD.151</u>)	OFF
Pitot heating (if installed)	OFF
Landing and taxi lights	OFF
Instrument lights	OFF
Main switch	OFF

BEFORE STARTING ENGINE

Preflight inspection	Carried out
Doors	CLOSED, check catches in place
Main switch	OFF
Parking brake	Set
Seats, seat belts, shoulder harnesses	ADJUSTED and SECURE
Flight controls	Check operation
Pitch trim	Check deflection
Fuel selector	OPEN (L.H. or R.H.)
Circuit breakers (side panel)	Closed
Magneto selector	OFF
"Radio master" (if installed)	OFF
Alternate static source (if installed)	PUSHED

ENGINE STARTING

Main switch	ON
Parking brake light "PARK"	Illuminated
Anticollision lights (if installed)	ON

NORMAL PROCEDURE :

Carburetor heating	OFF
Propeller	FULL FORWARD
Mixture	FULL RICH
Fuel pump	ON
Pump warning light	ON
Fuel pressure or (<u>Post-MOD.182</u>)	Green Sector 0.5 psi < P < 8 psi
Injection	Throttle operated a few times
Throttle Area	1/4 OPEN Clear
Magneto/start selector	START (10 sec. maxi)

When the engine starts :

Magneto selector	BOTH
Oil pressure	Green Sector

If no oil pressure indication after 30 sec.,
shutdown engine.

Fuel pump	OFF
Engine	1000 to 1200 RPM during heating

HOT ENGINE PROCEDURE :

Same procedure as normal procedure, but without injection.

NOTE :

Refer to Section 2 "Limitations" for starter operation limits.

COLD WEATHER PROCEDURE :

Carburetor heating	OFF
Propeller	FULL FORWARD
Mixture	FULL RICH
Fuel pump	ON
Pump warning light	ON
Fuel pressure or (<u>Post-MOD.182</u>)	Green Sector 0.5 psi < P < 8 psi
Injection	Throttle operated 10 to 15 times
Throttle	1/4 OPEN
Area	Clear
Magneto / start selector	START (10 sec. maxi)

NOTE :

Refer to Section 2 "Limitations" for starter operation limits.

When the engine starts :

Magneto selector	BOTH
Oil pressure	Green Sector

If no oil pressure indication after 30 sec.,
shutdown engine.

Fuel pump	OFF
Engine	
- 1200 RPM until oil temperature pointer moves	
- 1500 RPM until oil temperature pointer reaches 50 % of yellow sector	
- 2000 RPM until oil temperature pointer reaches the green sector	

FLOODED ENGINE PROCEDURE :

NOTE :

Refer to Section 2 "Limitations" for starter operation limits.

Failed starting may be due to excess fuel resulting from repeated injection producing black smoke and back fire.

Proceed as follows :

Mixture	IDLE CUT-OFF
Throttle	FULL POWER
Magneto / start selector	START (10 sec. maxi)

Then, resume normal procedure without injection.

AFTER STARTING ENGINE

ELECTRICAL POWER CHECK :

“ALTr FLD” switch-breaker OFF

- “ALTr” warning light ON
- Voltmeter Yellow sector
or (Post-MOD.182) > 24

“ALTr FLD” switch-breaker ON

- “ALTr” warning light OFF
- Voltmeter Green sector
or (Post-MOD.182) 26 < V < 29

Turn-and-bank indicator (if installed) ON

Vacuum gage (if installed) Checked

Advisory panel test Positive

”Radio master” (if installed) ON

All radios and nav aids ON

Fuel selector Set to fullest tank

Flaps Checked and RETRACTED

TAXIING

Parking brake Release

Brakes Checked

Flight instruments Checked

Taxi light As required

Avoid exceeding 1200 RPM as long as the oil temperature indicator pointer is within yellow sector.

Steering the airplane with the rudder pedals only is generally sufficient. The combined use of the rudder pedals and the brakes permits, if necessary, tight turns.

Check operation of gyroscopic instruments (horizontal attitude, heading and turn-and-bank indicators) by means of alternate turns.

ENGINE RUN-UP

Parking brake	Set
Engine control friction	Adjusted
Oil temperature	Green sector
Oil pressure	Green sector
Fuel pressure	Green sector
or (Post-MOD.182) (warning light extinguished)	0.5 psi < P < 8 psi
Mixture	FULL RICH
Carburetor heating	OFF
Fuel selector	Set to fullest tank

PROPELLER CHECK :

Propeller	FULL FORWARD
Throttle	2000 RPM
Propeller	Cycle twice (maxi. 500 RPM drop) Return to high RPM (FULL FORWARD)

MAGNETO CHECK :

Throttle	2000 RPM
Magneto selector	L. then BOTH R. then BOTH
Maximum RPM drop on each magneto	175 RPM
Maximum difference between magnetos	50 RPM

CARBURETOR HEATING CHECK :

Carburetor heating	ON
Manifold pressure	Decrease
Carburetor temperature indicator (if installed)	Increase
Carburetor heating	OFF

MAXIMUM POWER CHECK :

Full throttle	2700 RPM
---------------	----------

BEFORE TAKE-OFF

Seats, seat belts, shoulder harnesses	Check
Doors	LOCKED
Controls	Free
Pitch trim	TAKE-OFF
Flaps	TAKE-OFF
Magneto selector	BOTH
Propeller	FULL FORWARD
Carburetor heating	OFF
Mixture	FULL RICH
Fuel selector	Check set to fullest tank
Fuel pump	ON
Oil temperature	Green sector
Oil pressure	Green sector
Fuel pressure	Green sector
or (<u>Post-MOD.182</u>) (warning light extinguished)	0.5 psi < P < 8 psi
Voltmeter	Green sector
or (<u>Post-MOD.182</u>)	26 < V < 29
Altimeter	Set
Heading indicator (if installed)	Set
Horizontal attitude gyro (if installed)	Set
Parking brake	RELEASE - Light OFF
Cabin blower (if installed)	OFF
Landing lights	As required
Navigation lights	As required
Pitot heating (if installed)	As required
Transponder (if installed)	As required

TAKE-OFF

Lined up on runway	Check heading gyro
	Check stand-by compass
Smoothly apply full power	
Engine parameters	Check
Airspeeds	See Section 5
	"Take-off performance"

STANDARD AIRSPEEDS :

Rotation	63 KIAS
Initial climb	70 KIAS

WHEN SAFELY AIRBORNE :

Brakes	Apply
AT 300 ft :	
Climb speed	73 KIAS
Flaps	RETRACT
AT 1000 ft :	
Fuel pump	OFF
External lights	As required

CLIMB

Mixture	FULL RICH
Throttle	FULL POWER
Propeller	FULL FORWARD (2700 RPM)
Optimum climb speed	80 KIAS

NOTE :

Climb can also be carried out at higher speeds (better visibility towards front, better engine cooling) and lower power ratings (lower noise level).

CAUTION

CLIMB AT BEST ANGLE OF CLIMB SHOULD BE USED ONLY IN EXCEPTIONAL CASES SINCE THE ENGINE IS LESS COOLED

CRUISE

Power	Adjusted
Pitch trim	Adjusted
Mixture	Adjusted

Normal cruise between 60 % and 75 %, see Section 5 "Performance".

Adjust mixture on "FULL RICH" for power higher than 75 %.

RECOMMENDATIONS :

In practice, it is recommended to change tank every half-hour when observing fuel pressure and not to exceed a fuel imbalance of 13.2 U.S Gallons (50 Litres).

During take-off from high elevation airport or during prolonged climbs, roughness or loss of power may result from overrichness.

In such a case, adjust mixture control only enough to obtain smooth operation and not for economy.

Rough operation due to overrich fuel / air mixture is most likely to be encountered at altitudes above 5000 ft.

CAUTION

ALWAYS ENRICH MIXTURE BEFORE INCREASING POWER

Flight into known icing conditions is PROHIBITED.

Unintentional icing conditions : see Section 3 "Emergency procedures", Paragraph "Icing".

Leave icing conditions as soon as possible.

Remember to replace the carburetor heating control in OFF position after leaving the icing area.

DESCENT

Power setting as required for descent.

Every 1500 ft, apply engine power to prevent excess engine cooling and spark plugs fouling.

If descent with reduced throttle :

Carburetor heating ON

Seats, seat belts,
shoulder harnesses ADJUSTED and SECURE

APPROACH - LANDING

FINAL :

Airspeed 78 KIAS

Flaps TAKE-OFF

Fuel pump ON

Mixture FULL RICH

Propeller FULL FORWARD

Carburetor heating ON or OFF

as required

Brakes Checked

Seats, seat belts,
shoulder harnesses ADJUSTED and SECURE

Landing lights ON

SHORT FINAL :

Flaps LANDING

Airspeed See Section 5

"Landing Performance"

Standard airspeeds 73 KIAS at 2535 lbs

GO-AROUND

Carburetor heating	OFF
Smoothly apply full power	
Airspeed	70 / 73 KIAS
When climb rate is positive :	
Flaps	TAKE-OFF
Airspeed	73 KIAS
Flaps	RETRACTED
Climb	78 KIAS

AFTER LANDING

Fuel pump	OFF
Flaps	RETRACTED
Landing light	OFF
Taxi light	As required
Trim	TAKE-OFF
Radio equipment	As required
Pitot heating (if installed)	OFF
Carburetor heating	OFF

SHUT-DOWN / SECURING AIRPLANE

Parking brake	Set
Turn and bank indicator (if installed)	OFF
Anticollision lights (if installed)	OFF
Taxi light	OFF
Lights	OFF
"Radio master" (if installed)	OFF
Throttle	REDUCED

WARNING

**THE TEST HEREAFTER MUST BE IMPERATIVELY
CARRIED OUT WITH ENGINE POWER LOWER
THAN 1000 RPM ; THE FAILURE TO OBSERVE THIS
RULE MAY LEAD TO EXHAUST SYSTEM DAMAGE**

Magnetos cut-off test (*)	OFF, then BOTH
Throttle	900 to 1000 RPM
Mixture	IDLE CUT-OFF

AFTER ENGINE STOPS :

Magneto selector	OFF
"ALTr FLD" switch-breaker	OFF
Main switch	OFF
Fuel selector	OFF
Protection for pitots and static ports	Installed
Control lock	Installed
Chocks/Tie-downs	If necessary

(*) Depending on the kind of operation, it is not necessary to perform this test more than once a day, but just before securing the airplane

PARTICULAR USES

STALLS

CAUTION

ATTEMPT PRACTICE STALLS ONLY WITH SUFFICIENT ALTITUDE FOR RECOVERY

Power-on stalls require an extremely steep pitch attitude. If the center of gravity is at or near its aft limit, a slight tendency toward wing rocking or a wing drop may occur when the stabilator is deflected near its stop.

Aerodynamic warning (pre-stall buffet) is low with power idle, and more pronounced at higher power settings. Stall recovery can be effected immediately by easing the stick forward. Altitude loss is minor in all cases and is minimized by prompt application of power at the onset of the stall.

The stall warning horn will sound from 5 to 10 knots before stall speed.

FLIGHT WITH CROSSWIND

TAKE-OFF :

Apply full power before brake release.

Aileron control moved into wind.

Keep the airplane on runway centerline using the rudder.

Maintain nose-wheel on ground up to 65 KIAS.

Lift-off cleanly in order to avoid subsequent touch-down.

LANDING :

When landing in a strong crosswind, use the landing flap setting.

Although the crab or combination method of drift correction may be used, the wing low method gives the best control. Maximum bank angle close to the ground is 15°.

After touch-down, keep the nose-wheel on the ground, hold a straight course using rudder pedals.

■ **FLIGHT IN TURBULENT AIR**

Maximum airspeed	128 KIAS
Recommended airspeed	108 KIAS
Seats, seat belts, shoulder harnesses	ADJUSTED and SECURE

USE OF DOORS

In windy or gusty conditions, the doors should be firmly held during opening and closing and should be closed and locked immediately after entering or leaving the airplane.

The doors must be closed and locked for all taxiing and flight operations.

SECTION 5

PERFORMANCE

TABLE OF CONTENTS

	Page
ACOUSTIC LIMITATION	5.3
AIRSPEED CALIBRATION	5.4
ALTITUDE COMPENSATION	5.4
STALLING SPEEDS	5.5
WIND COMPONENTS	5.6
NOTICE	5.7
TAKE-OFF PERFORMANCE	5.8
CLIMB PERFORMANCE	5.9
■ MAXIMUM PERFORMANCE ALTITUDE	5.11
ANTENNAS INFLUENCE ON PERFORMANCE	5.11
RATINGS TABLE	5.12
LEVEL FLIGHT PERFORMANCE	5.13
LANDING PERFORMANCE	5.24
CLIMB - FUEL CONSUMPTION - TIME - DISTANCE COVERED	5.28

INTENTIONALLY LEFT BLANK

ACOUSTIC LIMITATION

In compliance with decree dated 15th April 1977, the maximum noise level permissible for SOCATA Model TB 10 airplane corresponding to total maximum certification weight of 2535 lbs (1150 kg) is 75.3 d B (A).

The noise level which was determined in conditions stated by above-mentioned decree at maximum continuous power is 71.5 d B (A).

ICAO regulations

With a noise level lower than the limit noise level of 4.2 d B (A) the TB 10 airplane complies with Chapter 10, appendix 6, annex 16 of the agreement relative to International Civil Aviation Organization (ICAO).

The noise limit authorized in above-mentioned ICAO conditions is of 85.2 d B (A) at a maximum takeoff weight of 2535 lbs (1150 kg).

The noise level which was determined in above-mentioned ICAO conditions at maximum continuous power and at 2700 RPM is 81.0 d B (A).

In compliance with decree dated 30th July 1975, SOCATA Model TB 10 airplane has received the noise limitation type certificate Nr N165 dated 24th August 1979.

AIRSPPEED CALIBRATION

NORMAL STATIC SOURCE

$$\text{CAS} \approx \text{IAS}$$

Figure 5.1 - NORMAL STATIC SOURCE

NOTE :

The indicated airspeeds (IAS) suppose instrument error to be null.

ALTERNATE STATIC SOURCE

In case of alternate static source utilization, open air outlets and / or actuate cabin air selector flow lever to open position. Then, instrument error is slight.

ALTITUDE COMPENSATION

ALTERNATE STATIC SOURCE

In case of alternate static source utilization, open air outlets and / or actuate cabin air selector flow lever to open position. Then, instrument error is not significant.

STALLING SPEEDS

CONDITIONS : Weight : 2535 lbs (1150 kg)

Power OFF

CONFIGURATION	BANK					
	0°		30°		45°	
	KIAS	MPH IAS	KIAS	MPH IAS	KIAS	MPH IAS
FLAPS RETRACTED	60	70	65	75	72	83
FLAPS TAKE-OFF	57	66	62	71	68	78
FLAPS LANDING	53	61	57	66	63	73

NOTE :

The indicated airspeeds (IAS) suppose instrument error to be null.

Figure 5.2 - STALLING SPEEDS

WIND COMPONENTS

EXAMPLE: Wind speed : 20 kt
 Angle between wind direction and flight path : 50°
 Headwind : 13 kt
 Crosswind : 15 kt

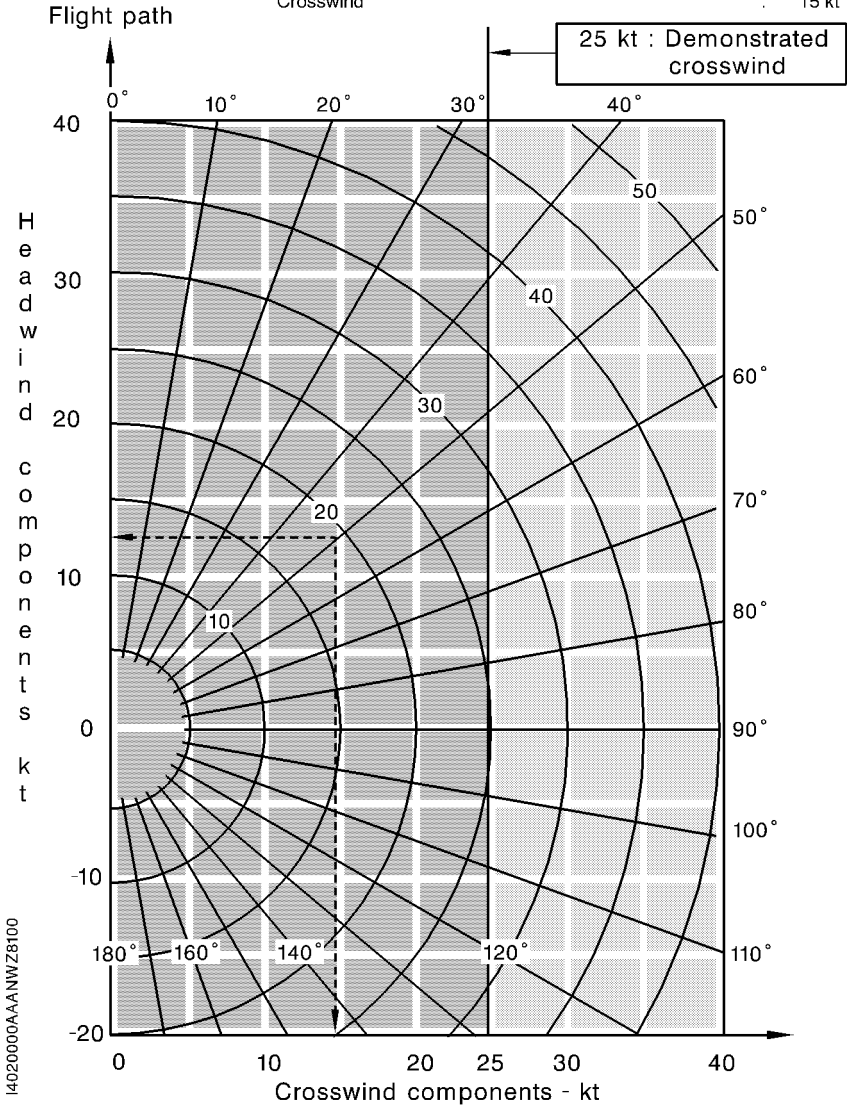

14020000AAAANWZ8100

Figure 5.3 - WIND COMPONENTS

NOTICE

Measurements were taken with zero wind condition on dry and hard runway.

The performance are presented as a function of the altitude in feet and the temperature at the considered altitude.

Take-off and landing performance figures are based on a dry hard surface runway.

The total take-off and landing distances (taxiing and clear 50 ft) will be corrected as follows :

- Influence of runway condition :
 - Increase by : 7 % on hard sod
 10 % on short grass
 25 % on high grass
- Influence of wind :
 - . Increase by 30 % for each 10 kt rear wind
 - . Reduce by 10 % for each 10 kt headwind.

TAKE-OFF PERFORMANCE

Flaps extended

The take-off runs correspond to tests conducted (in TARBES-OSSUN), on tarred runway and compensated for concrete runway.

TAKE-OFF PERFORMANCE

CONDITIONS : IAS : Lift off : 59 KIAS - 68 MPH IAS
 Clear 50 ft : 65 KIAS - 75 MPH IAS
 Weight : 2535 lbs (1150 kg)

NOTE :
 See Paragraph "NOTICE" for corrections due to wind and runway condition.

Temperature	Distance	Pressure altitude (ft)				
		0	2000	4000	6000	8000
- 4°F (-20°C)	Roll (ft)	837	1001	1214	1460	1755
	Clear 50 ft (ft)	1296	1558	1886	2329	2920
+ 32°F (0°C)	Roll (ft)	968	1165	1394	1690	2051
	Clear 50 ft (ft)	1476	1804	2198	2739	3478
+ 59°F (+ 15°C)	Roll (ft)	1066	1280	1542	1870	2297
	Clear 50 ft (ft)	1657	2001	2461	3084	4035
+ 86°F (+ 30°C)	Roll (ft)	1181	1427	1722	2297	2543
	Clear 50 ft (ft)	1837	2231	2756	3478	4626
+ 104°F (+ 40°C)	Roll (ft)	1280	1542	1837	2231	2707
	Clear 50 ft (ft)	1968	2411	2969	3789	5118

Figure 5.4 - TAKE-OFF PERFORMANCE

CLIMB PERFORMANCE

CONDITIONS : Climb speed : 78 KIAS - 90 MPH IAS
 Weight : 2535 lbs (1150 kg)
Airplane equipped with wheel fairings
 Flaps retracted

PRESSURE ALTITUDE (ft)	CLIMB SPEED									
	- 4°F (- 20°C)		+ 32°F (0°C)		+ 59°F (+ 15°C)		+ 86°F (+ 30°C)		+ 104°F (+ 40°C)	
	m/s	ft/min	m/s	ft/min	m/s	ft/min	m/s	ft/min	m/s	ft/min
0	4.68	921	4.29	844	4.00	787	3.72	732	3.54	697
2000	4.06	799	3.68	724	3.40	669	3.14	618	2.97	585
4000	3.41	671	3.04	598	2.78	547	2.53	498	2.36	465
6000	2.78	547	2.43	478	2.17	427	1.93	380	1.77	348
8000	2.17	427	1.84	362	1.59	313	1.35	266	1.20	236

Figure 5.5 - CLIMB PERFORMANCE

CLIMB PERFORMANCE

CONDITIONS : Climb speed : 78 KIAS - 90 MPH IAS
 Weight : 2535 lbs (1150 kg)
Airplane without wheel fairings : option Nr 525
 Flaps retracted

PRESSURE ALTITUDE (ft)	CLIMB SPEED									
	- 4°F (- 20°C)		+ 32°F (0°C)		+ 59°F (+ 15°C)		+ 86°F (+ 30°C)		+ 104°F (+ 40°C)	
	m/s	ft/min	m/s	ft/min	m/s	ft/min	m/s	ft/min	m/s	ft/min
0	4.02	792	3.68	726	3.44	677	3.19	630	3.04	599
2000	3.49	687	3.16	623	2.92	575	2.70	531	2.55	503
4000	2.93	577	2.61	514	2.39	470	2.17	428	2.02	400
6000	2.39	470	2.08	411	1.86	367	1.65	327	1.52	299
8000	1.86	367	1.58	311	1.36	269	1.16	229	1.03	203

Figure 5.6 - CLIMB PERFORMANCE

MAXIMUM PERFORMANCE ALTITUDE

Maximum performance altitude in standard temperature condition (ISA), corresponding to a vertical speed of 100 ft/min, is 13000 ft at take-off maximum weight.

ANTENNAS INFLUENCE ON PERFORMANCE

Installation of radio antennas reduces cruise performance as follows :

AERIAL	CRUISE SPEED		RANGE
	KIAS	MPH IAS	
VHF	- 0.48	- 0.56	- 0.30 %
VOR	- 0.59	- 0.68	- 0.37 %
Glide	- 0.32	- 0.37	- 0.20 %
ADF Loop antenna	- 0.75	- 0.87	- 0.47 %
ELT	- 0.16	- 0.19	- 0.10 %
Anticollision light	- 0.16	- 0.19	- 0.10 %
Strobe lights	- 0.43	- 0.50	- 0.27 %
Example : IFR	- 3.23	- 3.73	- 2 %

Figure 5.7 - ANTENNAS INFLUENCE ON PERFORMANCE

RATINGS TABLE - ENGINE LYCOMING O-360-A1AD

% BHP	PRESSURE ALTITUDE ft	MANIFOLD PRESSURE in.Hg		
		2350 RPM	2450 RPM	2700 RPM
75	0	24.6	24.1	23.1
	2000	24.1	23.6	22.4
	4000	23.6	23	22
	6000		22.5	21.5
	8000			21
65	0	22.2	21.8	20.7
	2000	21.7	21.2	20.3
	4000	21.2	20.7	19.8
	6000	20.7	20.2	19.4
	8000	20.2	19.7	19
55	0	21	20.6	
	2000	20.5	20.1	
	4000	20	19.6	/
	6000	19.5	19.1	
	8000	19	18.7	

Recommended values : **Italic numbers**

Add 0.5 in.Hg to manifold pressure per fraction of 18°F (10°C) above standard temperature.

Decrease manifold pressure by 0.5 in.Hg per fraction of 18°F (10°C) under standard temperature.

Figure 5.8 - RATINGS TABLE

LEVEL FLIGHT PERFORMANCE

Level flight performance are given for a take-off weight of 2535 lbs (1150 kg) and for setting "Best Power" obtained with an EGT indicator.

Fuel : 53.8 U.S Gal (204 litres) usable

Endurance without reserves

The endurances and ranges specified correspond to complete use of the fuel at the indicated altitude without allowing for take-off, climb, and so on...

Endurance with reserves

The endurances and ranges specified correspond to the use of the fuel allowing for take-off, climb, descent, indicated altitude and with a fuel reserve of 6.07 U.S Gal (23 litres) corresponding to 45 min flight at 50 % of the maximum power.

Various parameters such as the mixture setting, engine and propeller condition and the atmospheric conditions (wind, moisture, temperature, and so on...) may noticeably vary the endurance and range.

Performance with minimum consumption

- Decrease speeds by 2 KIAS - 2 MPH IAS
- Decrease fuel consumption by 1.32 U.S Gal/hr (5 litres/hr)
- Add 15 % to distance to be cleared.

Settings with an EGT indicator :

- Best economy mixture : from full rich, weaken slowly mixture until peak EGT.
- Best power mixture : From peak EGT, re-enrich until EGT temperature decreases by 75°F (3 divisions).

Settings without an EGT indicator :

- Best economy mixture : from full rich, weaken slowly until first engine malfunctioning signs (vibration) appear and then re-enrich slowly.

PRESSURE ALTITUDE : 2000 ft

ISA : 52°F (11°C)

Airplane with wheel fairings

N (RPM)	2700		2600		2500		2400		2300	
MP (in.Hg)	22.1		23.6		23.6		25		25	
	20.7		22.1		22.1		23.6		23.6	
	19.2		20.7		20.7		22.1		22.1	
			19.2		19.2		20.7		20.7	
% BHP (rounded)	73		78		76		81		78	
	67		72		70		74		72	
	60		65		63		68		66	
			58		57		62		60	
TAS	KTAS	MPH	KTAS	MPH	KTAS	MPH	KTAS	MPH	KTAS	MPH
	119	137	122	141	121	140	124	143	122	141
	114	132	118	136	117	135	120	138	118	136
	108	124	113	130	112	129	115	133	113	130
		106	122	104	119	110	127	108	124	
C (U.S Gal/hr)	11.4		11.7		11		11.5		11.1	
	10.4		10.6		10		10.5		10.1	
	9.4		9.6		9.1		9.6		9.2	
			8.8		8.4		8.7		8.4	
Distance to be cleared without reserves	h.min	SM	h.min	SM	h.min	SM	h.min	SM	h.min	SM
	4.42	646	4.37	649	4.53	684	4.40	665	4.41	662
	5.12	687	5.05	690	5.22	724	5.07	708	5.20	727
	5.43	711	5.36	727	5.54	758	5.38	749	5.51	764
		6.06	743	6.25	764	6.10	783	6.23	792	
Distance to be cleared with reserves	h.min	SM	h.min	SM	h.min	SM	h.min	SM	h.min	SM
	4.07	562	4.02	565	4.17	593	4.11	593	4.14	593
	4.32	597	4.26	600	4.42	631	4.29	615	4.39	531
	5.00	618	4.53	631	5.06	657	4.49	649	5.06	662
		5.19	646	5.35	665	5.23	677	5.34	690	

Figure 5.9 - LEVEL FLIGHT PERFORMANCE (2000 ft)

PRESSURE ALTITUDE : 2000 ft

ISA : 52°F (11°C)

Airplane without wheel fairings : option Nr 525

N (RPM)	2700		2600		2500		2400		2300	
MP (in.Hg)	22.1		23.6		23.6		25		25	
	20.7		22.1		22.1		23.6		23.6	
	19.2		20.7		20.7		22.1		22.1	
% BHP (rounded)	73		78		76		81		78	
	67		72		70		74		72	
	60		65		63		68		66	
TAS	KTAS	MPH	KTAS	MPH	KTAS	MPH	KTAS	MPH	KTAS	MPH
	110	127	113	130	112	129	114	132	113	130
	106	122	108	125	108	124	111	127	109	126
	99	114	104	119	103	118	106	122	105	121
			97	112	96	110	101	117	99	114
C (U.S Gal/hr)	11.4		11.7		11		11.5		11.1	
	10.4		10.6		10		10.5		10.1	
	9.4		9.6		9.1		9.6		9.2	
			8.8		8.4		8.7		8.4	
Distance to be cleared without reserves	h.min	SM	h.min	SM	h.min	SM	h.min	SM	h.min	SM
	4.42	597	4.37	600	4.53	630	4.40	613	4.41	609
	5.12	634	5.05	635	5.22	665	5.07	650	5.20	672
	5.43	652	5.36	666	5.54	696	5.38	687	5.51	708
			6.06	683	6.25	706	6.10	722	6.23	728
Distance to be cleared with reserves	h.min	SM	h.min	SM	h.min	SM	h.min	SM	h.min	SM
	4.07	518	4.02	519	4.17	547	4.11	544	4.14	546
	4.32	549	4.26	550	4.42	580	4.29	565	4.39	580
	5.00	568	4.53	577	5.06	602	4.49	588	5.06	608
			5.19	593	5.35	612	5.23	621	5.34	633

Figure 5.10 - LEVEL FLIGHT PERFORMANCE (2000 ft)

PRESSURE ALTITUDE : 4000 ft

ISA : 45°F (7°C)

Airplane with wheel fairings

N (RPM)	2700		2600		2500		2400		2300	
MP (in.Hg)	22.1		23.6		23.6		23.6		23.6	
	20.7		22.1		22.1		22.1		22.1	
	19.2		20.7		20.7		20.7		20.7	
% BHP (rounded)	76		80		79		77		74	
	69		74		72		70		68	
	62		67		66		64		62	
TAS	KTAS	MPH	KTAS	MPH	KTAS	MPH	KTAS	MPH	KTAS	MPH
	123	142	126	145	125	144	124	142	122	140
	118	136	122	140	120	139	119	137	117	135
	112	129	117	135	115	132	113	130	111	128
C (U.S Gal/hr)	11.8		12.1		11.4		10.9		10.4	
	10.7		11		10.3		9.9		9.6	
	9.7		9.9		9.7		9		8.7	
			9.1		8.5		8.3			
Distance to be cleared without reserves	h.min	SM	h.min	SM	h.min	SM	h.min	SM	h.min	SM
	4.32	640	4.27	646	4.43	677	4.57	702	5.09	724
	5.02	684	4.55	690	5.13	721	5.27	746	5.40	764
	5.34	715	5.25	730	5.32	733	6.00	783	6.12	792
Distance to be cleared with reserves	h.min	SM	h.min	SM	h.min	SM	h.min	SM	h.min	SM
	3.58	550	3.53	553	4.07	581	4.19	603	4.29	618
	4.28	587	4.17	590	4.32	618	4.44	637	4.54	652
	4.49	612	4.42	624	4.48	624	5.11	668	5.23	677
		5.08	640	5.26	665	5.35	671			

Figure 5.11 - LEVEL FLIGHT PERFORMANCE (4000 ft)

PRESSURE ALTITUDE : 4000 ft

ISA : 45°F (7°C)

Airplane without wheel fairings : option Nr 525

N (RPM)	2700		2600		2500		2400		2300	
MP (in.Hg)	22.1		23.6		23.6		23.6		23.6	
	20.7		22.1		22.1		22.1		22.1	
	19.2		20.7		20.7		20.7		20.7	
% BHP (rounded)	76		80		79		77		74	
	69		74		72		70		68	
	62		67		66		64		62	
TAS	KTAS	MPH	KTAS	MPH	KTAS	MPH	KTAS	MPH	KTAS	MPH
	113	130	116	134	115	132	114	131	112	129
	108	125	112	129	111	127	110	126	108	124
	103	118	108	124	106	122	104	120	103	118
C (U.S Gal/hr)	11.9		12.1		11.4		10.9		10.4	
	10.7		11		10.3		9.9		9.6	
	9.7		9.9		9.7		9		8.7	
			9.1		8.5		8.3			
Distance to be cleared without reserves	h.min	SM	h.min	SM	h.min	SM	h.min	SM	h.min	SM
	4.32	589	4.27	685	4.43	623	4.57	648	5.09	664
	5.02	629	4.55	634	5.13	663	5.27	687	5.40	703
	5.34	657	5.25	672	5.32	655	6.00	720	6.12	732
Distance to be cleared with reserves	h.min	SM	h.min	SM	h.min	SM	h.min	SM	h.min	SM
	3.58	508	3.53	506	4.07	534	4.19	553	4.29	571
	4.28	537	4.17	540	4.32	568	4.44	587	4.54	602
	4.49	562	4.42	574	4.48	574	5.11	618	5.23	621
		5.08	587	5.26	612	5.35	621			

Figure 5.12 - LEVEL FLIGHT PERFORMANCE (4000 ft)

PRESSURE ALTITUDE : 6000 ft

ISA : 37°F (3°C)

Airplane with wheel fairings

N (RPM)	2700		2600		2500		2400		2300	
MP (in.Hg)	22.1		22.1		22.1		22.1		22.1	
	20.7		20.7		20.7		20.7		20.7	
	19.2		19.2		19.2		19.2		19.2	
% BHP (rounded)	78		76		74		73		70	
	71		69		68		66		64	
	64		63		61		60		58	
TAS	KTAS	MPH	KTAS	MPH	KTAS	MPH	KTAS	MPH	KTAS	MPH
	127	146	125	144	125	144	123	142	121	139
	122	140	120	139	119	137	117	135	115	132
	115	132	113	130	111	128	109	126	105	121
C (U.S Gal/hr)	12.2		11.3		10.7		10.2		9.9	
	11.1		10.3		9.7		9.3		8.9	
	9.9		9.3		8.9		8.5		8.2	
Distance to be cleared without reserves	h.min	SM	h.min	SM	h.min	SM	h.min	SM	h.min	SM
	4.25	643	4.46	687	5.02	721	5.16	746	5.28	761
	4.52	684	5.14	724	5.33	761	5.48	783	6.00	792
	5.25	718	5.48	755	6.06	783	6.21	795	6.32	789
Distance to be cleared with reserves	h.min	SM	h.min	SM	h.min	SM	h.min	SM	h.min	SM
	3.53	550	4.10	587	4.23	615	4.35	634	4.44	646
	4.15	581	4.33	618	4.49	646	5.01	665	5.11	671
	4.42	612	5.00	640	5.16	665	5.28	671	5.37	668

Figure 5.13 - LEVEL FLIGHT PERFORMANCE (6000 ft)

PRESSURE ALTITUDE : 6000 ft

ISA : 37°F (3°C)

Airplane without wheel fairings : option Nr 525

N (RPM)	2700		2600		2500		2400		2300	
MP (in.Hg)	22.1		22.1		22.1		22.1		22.1	
	20.7		20.7		20.7		20.7		20.7	
	19.2		19.2		19.2		19.2		19.2	
% BHP (rounded)	78		76		74		73		70	
	71		69		68		66		64	
	64		63		61		60		58	
TAS	KTAS	MPH	KTAS	MPH	KTAS	MPH	KTAS	MPH	KTAS	MPH
	117	134	115	133	115	132	113	130	111	128
	112	129	111	127	110	126	108	124	106	122
	106	122	104	120	103	118	100	116	97	111
C (U.S Gal/hr)	12.2		11.3		10.7		10.2		9.9	
	11.1		10.3		9.7		9.3		8.9	
	9.9		9.3		8.9		8.5		8.2	
Distance to be cleared without reserves	h.min	SM	h.min	SM	h.min	SM	h.min	SM	h.min	SM
	4.25	592	4.46	634	5.02	664	5.16	685	5.28	700
	4.52	628	5.14	665	5.33	699	5.48	719	6.00	732
	5.25	661	5.48	696	6.06	720	6.21	735	6.32	725
Distance to be cleared with reserves	h.min	SM	h.min	SM	h.min	SM	h.min	SM	h.min	SM
	3.53	506	4.10	537	4.23	568	4.35	580	4.44	593
	4.15	534	4.33	565	4.49	593	5.01	612	5.11	615
	4.42	562	5.00	587	5.16	608	5.28	615	5.37	621

Figure 5.14 - LEVEL FLIGHT PERFORMANCE (6000 ft)

PRESSURE ALTITUDE : 8000 ft

ISA : 30°F (- 1°C)

Airplane with wheel fairings

N (RPM)	2700		2600		2500		2400		2300	
MP (in.Hg)	20.7		20.7		20.7		20.7		20.7	
	19.2		19.2		19.2		19.2		19.2	
	17.7		17.7							
% BHP (rounded)	74		72		70		68		66	
	66		65		63		62		60	
	59		58							
TAS	KTAS	MPH	KTAS	MPH	KTAS	MPH	KTAS	MPH	KTAS	MPH
	125	144	124	143	122	141	121	139	119	137
	119	137	117	134	115	132	112	129	109	126
	107	123	103	118						
C (U.S Gal/hr)	11.4		10.6		10		9.6		9.2	
	10.2		9.6		9.1		8.7		8.5	
	9.3		8.7							
Distance to be cleared without reserves	h.min	SM	h.min	SM	h.min	SM	h.min	SM	h.min	SM
	4.42	677	5.05	727	5.22	758	5.37	780	5.49	798
	5.15	718	5.37	752	5.55	783	6.10	798	6.22	798
	5.48	715	6.09	727						
Distance to be cleared with reserves	h.min	SM	h.min	SM	h.min	SM	h.min	SM	h.min	SM
	4.09	575	4.27	612	4.41	637	4.52	656	5.02	668
	4.35	606	4.52	634	5.07	659	5.19	671	5.28	671
	5.02	603	5.18	615						

Figure 5.15 - LEVEL FLIGHT PERFORMANCE (8000 ft)

PRESSURE ALTITUDE : 8000 ft

ISA : 30°F (- 1°C)

Airplane without wheel fairings : option Nr 525

N (RPM)	2700		2600		2500		2400		2300	
MP (in.Hg)	20.7		20.7		20.7		20.7		20.7	
	19.2		19.2		19.2		19.2		19.2	
	17.7		17.7							
% BHP (rounded)	74		72		70		68		66	
	66		65		63		62		60	
	59		58							
TAS	KTAS	MPH	KTAS	MPH	KTAS	MPH	KTAS	MPH	KTAS	MPH
	115	132	114	132	113	130	111	128	110	126
	110	126	107	124	106	122	104	119	100	116
	99	114	94	109						
C (U.S Gal/hr)	11.4		10.6		10		9.6		9.2	
	10.2		9.6		9.1		8.7		8.5	
	9.3		8.7							
Distance to be cleared without reserves	h.min	SM	h.min	SM	h.min	SM	h.min	SM	h.min	SM
	4.42	620	5.05	671	5.22	698	5.37	719	5.49	733
	5.15	662	5.37	696	5.55	722	6.10	734	6.22	739
	5.48	661	6.09	670						
Distance to be cleared with reserves	h.min	SM	h.min	SM	h.min	SM	h.min	SM	h.min	SM
	4.09	528	4.27	562	4.41	584	4.52	600	5.02	612
	4.35	526	4.52	581	5.07	603	5.19	615	5.28	615
	5.02	553	5.18	565						

Figure 5.16 - LEVEL FLIGHT PERFORMANCE (8000 ft)

PRESSURE ALTITUDE : 10000 ft

ISA : 23°F (- 5°C)

Airplane with wheel fairings

N (RPM)	2700		2600		2500		2400		2300	
MP (in.Hg)	19.2 17.7		19.2		19.2		19.2		19.2	
% BHP (rounded)	68 61		67		65		64		62	
TAS	KTAS	MPH	KTAS	MPH	KTAS	MPH	KTAS	MPH	KTAS	MPH
	122 110	141 127	120	139	119	137	116	134	113	130
C (U.S Gal/hr)	10.6 9.5		9.9		9.4		9		8.7	
Distance to be cleared without reserves	h.min	SM	h.min	SM	h.min	SM	h.min	SM	h.min	SM
	5.06 5.40	718 718	5.28	758	5.45	786	6.00	802	6.10	802
Distance to be cleared with reserves	h.min	SM	h.min	SM	h.min	SM	h.min	SM	h.min	SM
	4.30 4.56	603 603	4.47	634	5.01	656	5.11	668	5.20	668

Figure 5.17 - LEVEL FLIGHT PERFORMANCE (10000 ft)

PRESSURE ALTITUDE : 10000 ft

ISA : 23°F (- 5°C)

Airplane without wheel fairings :option Nr 525

N (RPM)	2700		2600		2500		2400		2300	
MP (in.Hg)	19.2 17.7		19.2		19.2		19.2		19.2	
% BHP (rounded)	68 61		67		65		64		62	
TAS	KTAS	MPH	KTAS	MPH	KTAS	MPH	KTAS	MPH	KTAS	MPH
	113 101	130 117	111	128	109	126	107	123	104	119
C (U.S Gal/hr)	10.6 9.5		9.9		9.4		9		8.7	
Distance to be cleared without reserves	h.min	SM	h.min	SM	h.min	SM	h.min	SM	h.min	SM
	5.06 5.40	663 663	5.28	700	5.45	725	6.00	738	6.10	734
Distance to be cleared with reserves	h.min	SM	h.min	SM	h.min	SM	h.min	SM	h.min	SM
	4.30 4.56	553 553	4.47	581	5.01	597	5.11	612	5.20	612

Figure 5.18 - LEVEL FLIGHT PERFORMANCE (10000 ft)

LANDING PERFORMANCE

WEIGHT : 2407 lbs (1092 kg)

CONDITIONS : Clear 50 ft : 72 KIAS – 83 MPH IAS
Flaps in landing position

NOTE :

See Paragraph "NOTICE" for corrections due to wind and runway condition.

Temperature	Distance	Pressure altitude (ft)				
		0	2000	4000	6000	8000
- 4°F (- 20°C)	Roll (ft)	560	610	660	715	765
	Clear 50 ft (ft)	1275	1355	1440	1545	1665
+ 32°F (0°C)	Roll (ft)	610	660	715	765	830
	Clear 50 ft (ft)	1360	1460	1545	1665	1765
+ 59°F (+ 15°C)	Roll (ft)	650	695	745	815	880
	Clear 50 ft (ft)	1425	1525	1630	1730	1835
+ 86°F (+ 30°C)	Roll (ft)	680	730	780	850	917
	Clear 50 ft (ft)	1495	1595	1695	1815	1935
+ 104°F (+ 40°C)	Roll (ft)	695	745	815	880	950
	Clear 50 ft (ft)	1545	1630	1750	1865	1985

Figure 5.19 - LANDING PERFORMANCE [2407 lbs (1092 kg)]
(Flaps in landing position)

LANDING PERFORMANCE

WEIGHT : 2535 lbs (1150 kg)

CONDITIONS : Clear 50 ft : 73 KIAS - 84 MPH IAS
Flaps in landing position

NOTE :

See Paragraph "NOTICE" for corrections due to wind and runway condition.

Temperature	Distance	Pressure altitude (ft)				
		0	2000	4000	6000	8000
- 4°F (- 20°C)	Roll (ft)	591	640	689	738	787
	Clear 50 ft (ft)	1345	1427	1526	1624	1739
+ 32°F (0°C)	Roll (ft)	640	689	738	787	886
	Clear 50 ft (ft)	1427	1542	1624	1739	1870
+ 59°F (+ 15°C)	Roll (ft)	673	722	771	869	935
	Clear 50 ft (ft)	1509	1608	1706	1821	1936
+ 86°F (+ 30°C)	Roll (ft)	705	755	837	902	968
	Clear 50 ft (ft)	1575	1673	1772	1919	2034
+ 104°F (+ 40°C)	Roll (ft)	722	787	869	935	1001
	Clear 50 ft (ft)	1624	1706	1854	1969	2083

Figure 5.20 - LANDING PERFORMANCE [2535 lbs (1150 kg)]
(Flaps in landing position)

LANDING PERFORMANCE

WEIGHT : 2407 lbs (1092 kg)

CONDITIONS : Clear 50 ft : 78 KIAS – 90 MPH IAS
Flaps retracted

NOTE :

See Paragraph "NOTICE" for corrections due to wind and runway condition.

Temperature	Distance	Pressure altitude (ft)				
		0	2000	4000	6000	8000
- 4°F (- 20°C)	Roll (ft)	676	739	800	861	922
	Clear 50 ft (ft)	1537	1640	1742	1866	2010
+ 32°F (0°C)	Roll (ft)	739	800	861	922	1005
	Clear 50 ft (ft)	1640	1764	1866	2010	2132
+ 59°F (+ 15°C)	Roll (ft)	779	841	902	974	1052
	Clear 50 ft (ft)	1722	1845	1969	2091	2215
+ 86°F (+ 30°C)	Roll (ft)	820	881	944	1025	1107
	Clear 50 ft (ft)	1805	1927	2050	2194	2337
+ 104°F (+ 40°C)	Roll (ft)	855	920	984	1066	1149
	Clear 50 ft (ft)	1866	1969	2112	2255	2399

Figure 5.21 - LANDING PERFORMANCE [2407 lbs (1092 kg)]
(Flaps retracted)

LANDING PERFORMANCE

WEIGHT : 2535 lbs (1150 kg)

CONDITIONS : Clear 50 ft : 80 KIAS - 92 MPH IAS
Flaps retracted

NOTE :

See Paragraph "NOTICE" for corrections due to wind and runway condition.

Temperature	Distance	Pressure altitude (ft)				
		0	2000	4000	6000	8000
- 4°F (- 20°C)	Roll (ft)	711	777	842	906	970
	Clear 50 ft (ft)	1617	1725	1833	1963	2115
+ 32°F (0°C)	Roll (ft)	777	842	906	970	1057
	Clear 50 ft (ft)	1725	1858	1963	2115	2243
+ 59°F (+ 15°C)	Roll (ft)	820	885	949	1020	1121
	Clear 50 ft (ft)	1812	1941	2071	2200	2330
+ 86°F (+ 30°C)	Roll (ft)	863	927	993	1078	1165
	Clear 50 ft (ft)	1899	2027	2157	2308	2459
+ 104°F (+ 40°C)	Roll (ft)	885	949	1035	1121	1209
	Clear 50 ft (ft)	1963	2071	2222	2372	2524

Figure 5.22 - LANDING PERFORMANCE [2535 lbs (1150 kg)]
(Flaps retracted)

CLIMB - CONSUMPTION - TIME - DISTANCE COVERED

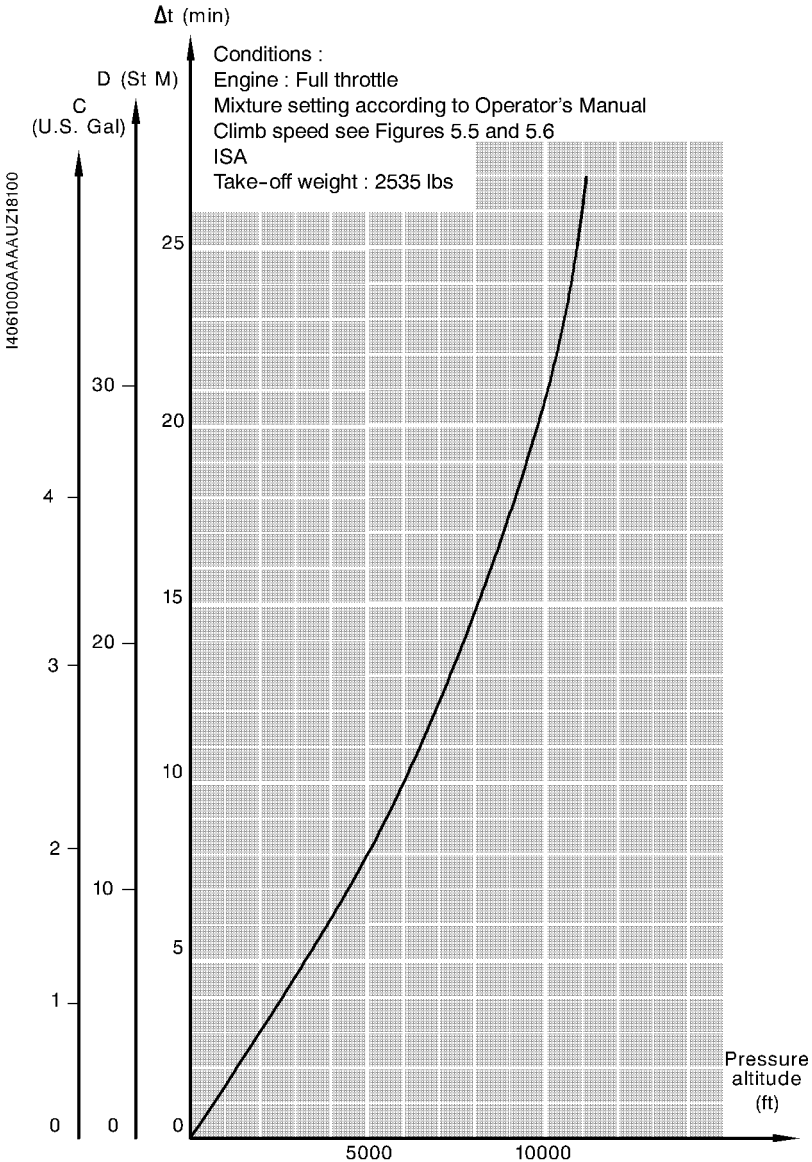

Figure 5.23 - CLIMB - CONSUMPTION - TIME - DISTANCE COVERED

SECTION 6

WEIGHT AND BALANCE

TABLE OF CONTENTS

	Page
GENERAL	6.2
AIRPLANE WEIGHING PROCEDURES	6.2
BAGGAGE/CARGO LOADING	6.2
BAGGAGE	6.2
CARGO	6.3
DETERMINING WEIGHT AND BALANCE	6.5
GENERAL	6.5
UTILIZATION OF WEIGHT/MOMENT GRAPH	6.5
EQUIPMENT LIST	6.12
<u>Pre-MOD.151</u>	6.13
<u>Post-MOD.151</u>	6.13A

GENERAL

This section contains the procedure for determining the basic empty weight and moment of SOCATA Model TB 10 airplane. Procedures for calculating the weight and moment for various operations are also provided. A list of equipment available for this airplane is included at the back of this section.

It should be noted that the list of specific optional equipment installed on your airplane as delivered from the factory can be found in the records carried in the airplane.

IT IS THE RESPONSIBILITY OF THE PILOT TO ENSURE THAT THE AIRPLANE IS LOADED PROPERLY.

AIRPLANE WEIGHING PROCEDURES

Refer to Maintenance Manual for the procedures to be used.

NOTE :

Weighing carried out at the factory takes into account all items of equipment installed on the airplane. The list of these items of equipment and the weighing result are noted in the Individual Inspection Record.

BAGGAGE/CARGO LOADING

BAGGAGE

The baggage compartment is located at the back of rear passengers bench or, Post-MOD.151, seats. Loading can either be carried out through baggage compartment access door provided with a locking device, located on L.H. side of the airplane, or from the inside of the cabin, on upper part of the back of the bench or, Post-MOD.151, of the rear seats. In this case, a zip fastener allows folding the sound-proofing cloth.

Tie-down straps are provided for securing baggage on compartment floor.

CARGO

To facilitate the carrying of equipment, large or bulky items, the rear bench or, Post-MOD.151, the rear seats may be removed from the airplane.

To remove rear bench or seats : See Figure 6.1 (A, B, C)

- Lift up seating (Item 6) (kept in position with "Velcro" straps) of rear bench or, Post-MOD.151, of rear seats then, in this case, remove arm rest.
- If you want to free the back from its support plate, lift it up about 1.5 inch (3 cm) at both ends and pull it forward so that both attaching pins free from apertures.
- To remove the support plate (Item 5) and back (Item 1) :
 - . Unfasten attachments of sound-proofing cloth on cross-beam (Item 2)
 - . Pushing, unscrew $\frac{1}{4}$ turn both attaching pins of air regulation duct on rear floor (Item 4)
 - . Pull both latches inwards (Item 3)
 - . Lift up support plate (Item 5) to disengage it forward.

NOTE :

To reinstall rear bench or, Post-MOD.151, rear seats - see Figure 6.1 (a, b, c) reverse removal instructions.

IMPERATIVELY RESPECT WEIGHT AND BALANCE LIMITS

THE PILOT IS RESPONSIBLE FOR CORRECT BAGGAGE AND / OR CARGO LOADING. PRIOR TO ANY FLIGHT HE MUST MAKE SURE THAT WEIGHT, BALANCE AND TIE-DOWN ARE CORRECT.

- **Baggage weight :**
Maximum 143 lbs (65 kg) at 102.36 in. (2.600 m)
- **Cargo weight (without baggage) :**
Maximum 573 lbs (260 kg) at 74.80 in. (1.900 m)

CAUTION

WHEN IN CARGO CONFIGURATION, NO PASSENGERS ARE ALLOWED IN THE CARGO AREA

- KEY
- ➔ REMOVAL
 - ⇨ INSTALLATION

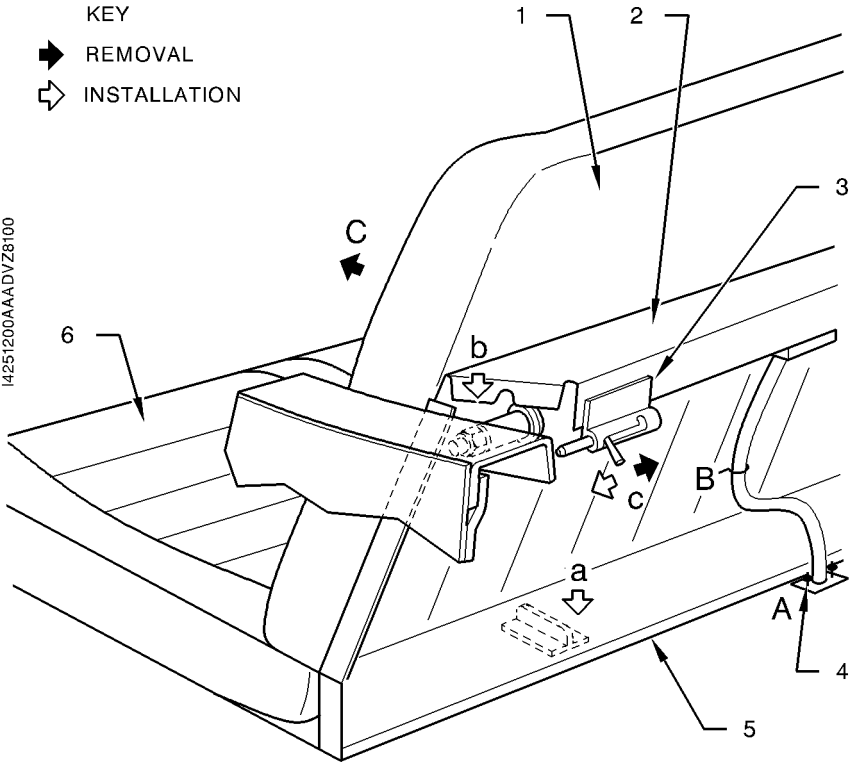

Figure 6.1 - REMOVAL AND INSTALLATION OF REAR BENCH OR, Post-MOD.151, REAR SEATS

DETERMINING WEIGHT AND BALANCE

GENERAL

This paragraph is intended to provide the pilot with a simple means of determining weight and balance of his airplane with regard to its empty characteristics and loading. The empty weight to be considered is the one noted on the last weighing form.

The data concerning loading are given on following graphs :

- Loading graph : see Figure 6.4
- Weight / Moment envelope : see Figure 6.5

To determine airplane loading within a given flight configuration, you only have to add up weights and moments of the various loads recorded and to add them to empty airplane data.

These values carried forward on weight / moment envelope must give a point within the limits drawn with continuous line.

If that is the case, loading is acceptable.

NOTE :

If moment is not directly known (optional equipment for example), determine it multiplying weight [lbs (kg)] by arm [in. (m)].

UTILIZATION OF WEIGHT / MOMENT GRAPH

Extract translucent Figure 6.5 from the manual and take a pencil.

- On Figure 6.5, place point A (1) corresponding to your empty airplane [Our sample loading : 1554 lbs (705 kg) - 59.17 lb.in / 1000 (662 m.kg)]
- Superpose point A (1) and point A of graph ① Figure 6.4.
- Draw on weight / moment envelope the pilot + front passenger straight line to get point A (2) corresponding to front seats loading. [Our sample loading : 2 persons 340 lbs (154 kg)].

- Superpose point A (2) and point A of graph ①, draw the rear passengers straight line to get point B (1) related to rear seat loading.
[Our sample loading : 2 persons 340 lbs (154 kg)]
- Superpose point B (1) and point B of graph ②, draw the fuel straight line to get point B (2).
[Our sample loading : 249 lbs (113 kg) - 41.45 U.S Gal (157 litres) fuel]
- Superpose point B (2) and point B of graph ②, draw the baggage straight line to get point M.
[Our sample loading : 33 lbs (15 kg) baggage]

Since point M falls within weight / moment envelope, the loading is acceptable.

NOTE :

Option No. 080000 M "L.H. or R.H. front seat back-off installation", option No. 080010 M "L.H. front seat back-off installation" and/or option No. 080020 M "R.H. front seat back-off installation" are marked on your airplane by a color ring (yellow / green) located on the 2 front supports (tubes) of each seat.

For C.G. location calculation, take 2-inch (50 mm) L.H. front seat or L.H. and R.H. front seats back-off installation into account.

SAMPLE WEIGHT AND BALANCE RECORD												
CONTINUOUS HISTORY OF CHANGES IN STRUCTURE OR EQUIPMENT AFFECTING WEIGHT AND BALANCE												
AIRPLANE MODEL :						SERIAL NUMBER :			PAGE NUMBER :			
DATE	ITEM No		DESCRIPTION OF EQUIPEMENT OR MODIFICATION	WEIGHT CHANGE						RUNNING BASIC EMPTYWEIGHT		
	IN	OUT		ADDED (+)			REMOVED (-)			WEIGHT lb	MOMENT lb.in/1000	
				WEIGHT lb	ARM in.	MOMENT lb.in/1000	WEIGHT lb	ARM in.	MOMENT lb.in/1000			
			As delivered									

Figure 6.2 - SAMPLE WEIGHT AND BALANCE RECORD

	SAMPLE AIRPLANE			YOUR AIRPLANE			Ref. on chart Figure 6.6
	Weight lb	Lever arm in.	Moment lb.in / 1000	Weight lb	Lever arm in.	Moment lb.in / 1000	
Empty weight	1554		59.17				A(1)
Pilot (without Opt. 0800)	170	45.38	7.71				} A(2)
Pilot (with Opt. 0800)	/	47.44	/				
Front passenger (without Opt. 0800)	170	45.38	7.71				
Front passenger (with Opt. 0800)	/	47.44	/				
Rear seat passengers	340	82.48	28.04				B(1)
Fuel (41.45 U.S Gal.)	249	42.32	10.54				B(2)
Baggage	33	97.05	3.20				
TOTAL WEIGHT AND MOMENT	2516		116.37				M

Figure 6.3 - SAMPLE LOADING

CAUTION

**OPTION(S) No. 080000 M (Qty 1 or 2) OR 080010 M AND 080020 M (See NOTE on page 6.6) :
2-in. (50 mm) back-off installation for L.H. and/or R.H. front seat(s)**

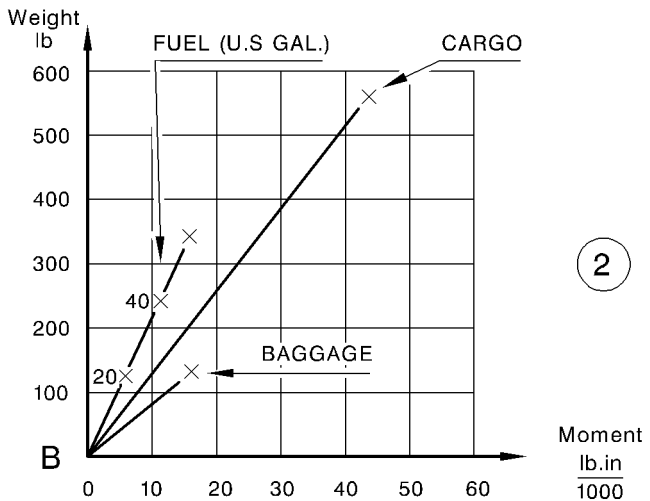
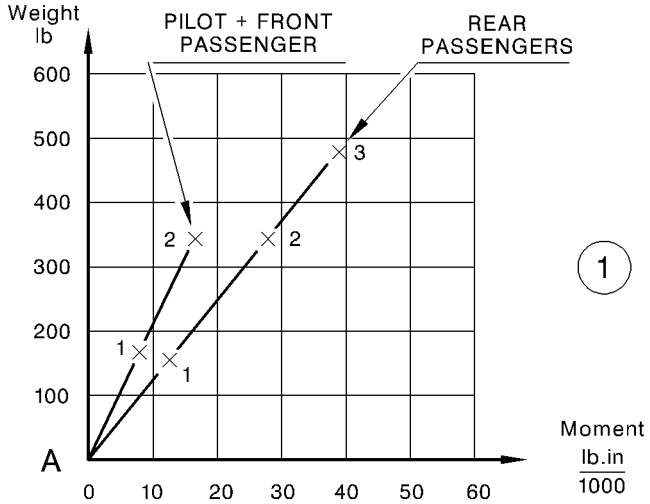

14081000AAACVZ18100

Figure 6.4 - LOADING GRAPHS

INTENTIONALLY LEFT BLANK

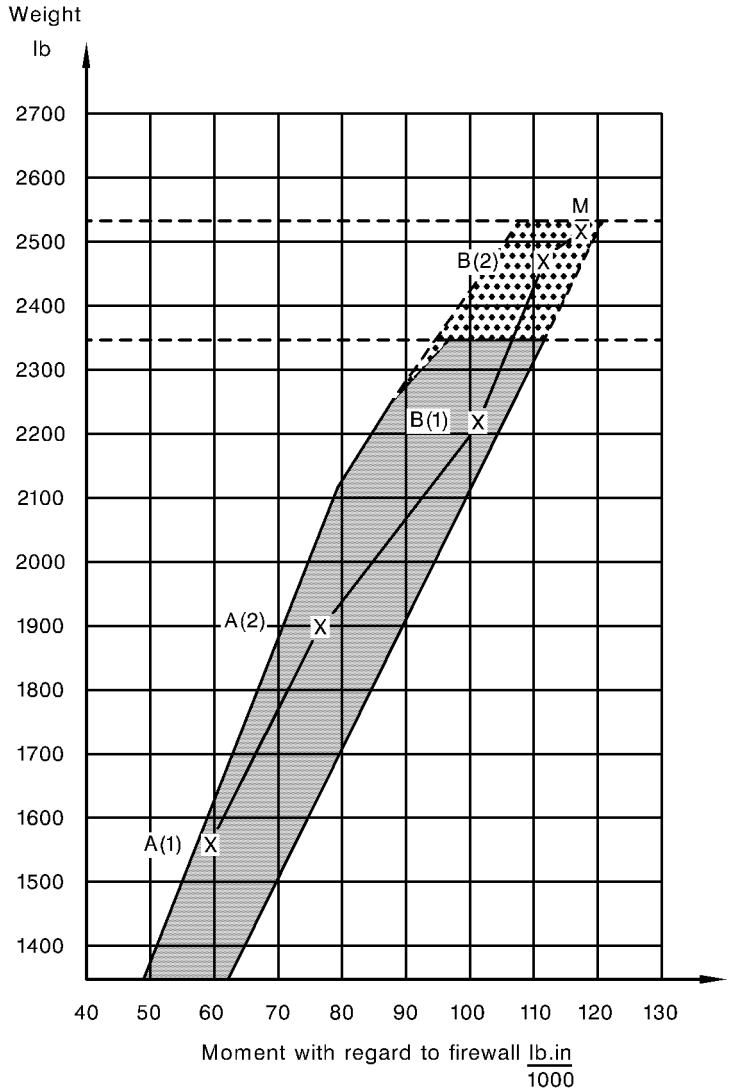

14080000AAADVZ18100

Figure 6.6 - LOADING SAMPLE

EQUIPMENT LIST

The following equipment list contains standard equipment installed on each airplane and available optional equipment.

A separate equipment list of items installed at the factory in your specific airplane is provided in your airplane file.

Columns showing weight (in pounds) and arm (in inches) provide the weight and center of gravity location for the equipment.

The equipment list provides the following information :

■ - Required or Standard items

- . A letter "R" or "S" allows classifying of the equipment :
 - "R" : equipment items required for certification
 - "S" : standard equipment items

■ - Optional equipment (not restrictive list)

- . A letter "O" or "A" allows classifying of the equipment :
 - "O" : optional equipment items replacing required or standard items
 - "A" : optional equipment items which are in addition to required or standard items
- . In the following column, an item number allows identification of the optional equipment.
- . The column marked "*" will be used to tick off the optional equipment installed on your airplane.

■ NOTE 1 :

Unless otherwise indicated (-), arms are positive values.

Positive arms are distances aft of the airplane datum ; negative arms are distances forward of the datum.

■ NOTE 2 :

Equipment list with "Pre-MOD. 151" validity :

S/N 948 to 1999, except S/N 1900

Equipment list with "Post-MOD. 151" validity :

S/N 2000 to 9999, plus S/N 1900

S/ R/ A/ O	ITEM OPT10	REQUIRED (R) OR STANDARD (S) OR OPTIONAL (A or O) EQUIPMENT	*	WEIGHT per unit lb (kg)	ARM in. (m)
		01 - SPECIFIC OPTIONAL EQUIPMENT			
A	H615 20M	Additional equipment for IFR France "Grey" - Up to S/N 1269 - From S/N 1270		0.441 /	25.59 /
A	H616 20M	Additional equipment for night VFR France "Grey"		0.441	25.59

S/ R/ A/ O	ITEM OPT10	REQUIRED (R) OR STANDARD (S) OR OPTIONAL (A or O) EQUIPMENT	*	WEIGHT per unit lb (kg)	ARM in. (m)
		21 - ENVIRONMENTAL SYSTEM			
		21-40 - Heating			
A	C598 00M	Radio console ventilation		1.543	6.30
A	C869 00M	Radio console forced ventilation (blower KING KA 33)		1.543	4.33
A	C869 20M	Radio console forced ventilation (blower KING KA 33)		1.543	12.99
A	F822 00M	Forced ventilation, rear passengers VETUS		2.756	136.61
A	F822 10M	Forced ventilation, rear passengers VETUS		2.756	136.61
A	F822 20M	Forced ventilation, rear passengers VETUS		2.756	136.61

S/ R/ A/ O	ITEM OPT10	REQUIRED (R) OR STANDARD (S) OR OPTIONAL (A or O) EQUIPMENT	*	WEIGHT per unit lb (kg)	ARM in. (m)
		22 - AUTO FLIGHT			
		22-12 - Autopilot			
A	D675 00M	Altitude and vertical speed preselector KAS 297B KING		1.764	21.65
A	D675 10M	Altitude and vertical speed preselector KAS 297B KING (on R.H. instrument panel)		1.764	21.65
A	D675 20M	Altitude and vertical speed preselector KAS 297B KING (on radio console)		1.764	21.65
A	G668 00M	A/P KAP 100 KING		11.442	35.43
A	G668 10M	A/P KAP 100 KING with electrical pitch trim		17.659	67.72
A	G669 00M	A/P KAP 150 KING		21.363	76.38
A	G670 00M	A/P KFC 150 KING		21.561	75.59
A	G810 00M	Remote A/P modes annunciator KA 185-03 for KAP 150		0.661	23.62
A	G810 10M	Remote A/P modes annunciator KA 185-01 for KFC 150		0.661	23.62

SECTION 6
WEIGHT AND BALANCE

SOCATA
MODEL TB 10

S/ R/ A/ O	ITEM OPT10	REQUIRED (R) OR STANDARD (S) OR OPTIONAL (A or O) EQUIPMENT	*	WEIGHT per unit lb (kg)	ARM in. (m)
		23 - COMMUNICATIONS			
		23-10 - Speech communications			
		23-11 - VHF capability			
A	23-001A	Audio selector/Intercom system PMA 7000MS PS ENGINEERING (stereo wiring)		3.814	26.77
A	23-001B	Audio selector/Intercom system PMA 7000MS PS ENGINEERING (mono wiring)		3.814	26.77
A	23-002A	Audio selector/Intercom system GMA 340 GARMIN		4.189	27.56
A	34-503A	Boom microphone headset AHX-05 Serie X BOSE		1.235	55.12
		- Pilot		0.683	55.12
		- Front passenger			
A	J524 30M	Interphone		0.441	11.81
A	J539 00M	VHF/COM capability (Loud-speaker "SONAVOX")		3.395	47.24
A	J539 20M	VHF/COM capability (Loud-speaker "AUDAX")		2.998	45.28
A	J688 00M	Boom microphone headset PELTOR		0.992	55.12
A	J827 00M	Intercommunication system SPA 400 ICS SIGTRONICS (Front and rear seats)		0.750	32.28
A	J827 10M	Intercommunication system SPA 400 AV SIGTRONICS (Front seats)		0.750	32.28
A	J893 00M	Headset (noise reducer) HDCII BOSE (pilot and front passenger)		4.189	55.12
A	J893 10M	Headset (noise reducer) HDCII BOSE (pilot)		2.094	55.12
A	J894 00M	VHF/COM capability		3.219	45.27
A	J894 20M	VHF/COM capability		3.219	45.27

S/ R/ A/ O	ITEM OPT10	REQUIRED (R) OR STANDARD (S) OR OPTIONAL (A or O) EQUIPMENT	*	WEIGHT per unit lb (kg)	ARM in. (m)
A	J912 00M	Boom microphone headset H10-13-4 DAVID CLARK		0.838	55.12
A	J928 00M	Boom microphone headset HMEC 25-KA SENNHEISER : Pilot and front passenger Rear passengers		0.661 0.661	55.12 94.49
A	J928 10M	Boom microphone headset HMEC 25-KAS SENNHEISER : Pilot and front passenger Rear passengers		0.661 0.661	55.12 94.49
A	K807 00M	Audio control box KMA 24H52 KING with interphone		2.205	27.56
A	K809 00M	Audio control box KMA 24H70 KING with audio selector threshold (4 transmitters/receivers)		2.381	31.50
A	K809 10M	Audio control box KMA 24H71 KING with audio selector threshold (5 transmitters/receivers)		2.381	31.50
A	K815 00M	Audio selection box KMA 24-02 KING		2.910	22.44
A	K815 10M	Audio selection box KMA 24-02 KING		2.910	22.44
A	052300 M	Boom microphone headset H10-30 DAVID CLARK 23-12 - COM 1 installation		1.190	55.12
A	K805 20M	VHF 1 KY 196 A 30 KING + KMA 24-02 (with VHF capability)		7.231	32.28
A	K805 30M	VHF 1 KY 196 A 30 KING (without VHF capability)		3.858	18.11
A	054910 M	VHF 1 faired antenna DMC 70 1/AX or DMC 70 1/A DORNE & MARGOLIN		0.661	127.32

S/ R/ A/ O	ITEM OPT10	REQUIRED (R) OR STANDARD (S) OR OPTIONAL (A or O) EQUIPMENT	*	WEIGHT per unit lb (kg)	ARM in. (m)
23-13 - COM 2 installation					
A	K805 00M	VHF 2 KY 196 A 30 KING		3.825	22.83
A	054920 M	VHF 2 faired antenna DMC 70 1/AX or DMC 70 1/A DORNE & MARGOLIN		0.661	57.95
23-60 - Static dischargers					
A	J884 00M	ESD protection		/	/

S/ R/ A/ O	ITEM OPT10	REQUIRED (R) OR STANDARD (S) OR OPTIONAL (A or O) EQUIPMENT	*	WEIGHT per unit lb (kg)	ARM in. (m)
		24 - ELECTRICAL POWER			
		24-30 - DC generation			
R		Alternator 70A ALU 8421 or ALU 8521 PRESTOLITE/ELECTROSYSTEMS or LW 14324 LYCOMING		12.985	- 37.80
R		Battery G242-10AH GILL		26.962	- 2.76
R		Battery relay 70 117 221.5 ESSEX		0.772	- 1.18
R		Voltage regulator TB20 61215 P/N BOO 368.5 LAMAR		0.375	3.94
A	C839 00M	Converter 28 V - 14 V LT- 71A KGS		1.653	39.37
A	D689 10M	Ammeter 28 V (with 60A shunt)		0.551	28.74
A	D907 00M	Voltmeter-ammeter indicator ELECTRONICS INTERNATIONAL		0.805	26.77
		24-40 - External power supply			
A	C825 00M	Ground power receptacle		3.527	47.24
A	C835 00M	Ground power receptacle (NATO)		3.682	49.61
A	C841 00M	Ground power extension (With option C835 00M)		4.740	91.73

SECTION 6
WEIGHT AND BALANCE

SOCATA
MODEL TB 10

S/ R/ A/ O	ITEM OPT10	REQUIRED (R) OR STANDARD (S) OR OPTIONAL (A or O) EQUIPMENT	*	WEIGHT per unit lb (kg)	ARM in. (m)
25 - EQUIPMENT AND FURNISHINGS					
25-10 - Cockpit					
O	F778 00M	Leather seats assembly "Grey 95" PMV with head-rests (F778 15M) : - Front seats (Qty 2) PMV - Rear seat PMV		58.598 17.064	49.21 84.65
O	F778 10M	Leather seats assembly "Chanel 95" PMV with head-rests (F778 25M) : - Front seats (Qty 2) PMV - Rear seat PMV		58.598 17.064	49.21 84.65
A	F779 15M	Front head-rests "Blue 90" (Qty 2)		3.417	51.18
A	F879 15M	Front head-rests "Blue 95" (Qty 2) PMV		3.461	55.12
A	F879 25M	Front head-rests "Ficelle 95" (Qty 2) PMV		3.461	55.12
A	F879 35M	Rear head-rests "Blue 95" (Qty 2) PMV		3.461	90.55
A	F879 45M	Rear head-rests "Ficelle 95" (Qty 2) PMV		3.461	90.55
O	067800 M	Leather seats assembly "Grey" PMV with head-rests (067815 M) : - Front seats (Qty 2) PMV - Rear seat PMV		48.060 19.555	49.21 84.65
O	067810 M	Leather seats assembly "Chanel" PMV with head-rests (067825 M) - Front seats (Qty 2) PMV - Rear seat PMV		48.060 19.555	49.21 84.65
A	067815 M	Leather head-rests "Grey" (Qty 2)		3.086	55.12 or 90.55
O	067820 M	Leather seats assembly "Grey" PMV with head-rests (067815 M) (Extended version) : - Front seats (Qty 2) PMV - Rear seat PMV		48.060 19.555	49.21 84.65

S/ R/ A/ O	ITEM OPT10	REQUIRED (R) OR STANDARD (S) OR OPTIONAL (A or O) EQUIPMENT	*	WEIGHT per unit lb (kg)	ARM in. (m)
A	067825 M	Leather head-rests "Chanel" (Qty 2)		3.086	55.12 or 90.55
O	067830 M	Leather seats assembly "Chanel" PMV with head-rests (067825M) (Extended version) : - Front seats (Qty 2) PMV - Rear seat PMV		48.060 19.555	49.21 84.65
A	067915 M	Head-rests "Cendre" (Qty 2)		2.161	55.12 or 90.55
A	067925 M	Head-rests "Sable" (Qty 2)		2.161	55.12 or 90.55
A	067935 M	Head-rests "Blue 95" (Qty 2) PMV		2.161	55.12 or 90.55
A	067945 M	Head-rests "Ficelle 95" (Qty 2) PMV		2.161	55.12 or 90.55
A	067955 M	Rear head-rests "Blue 95" (Qty 2) PMV		3.461	90.55
A	067965 M	Rear head-rests "Ficelle 95" (Qty 2) PMV		3.461	90.55
		25-11 - Front seats			
R		Front seats TB10 74030		18.298	51.18
R		Front seats TB10 74095		23.622	51.18
R		Front seats TB10 74106x00/01		24.625	49.21
R		Front seats TB10 74106x02/03		25.055	49.21
O	F779 00M	Front seats "Blue 90" (Qty 2)		52.117	49.21
O	F879 00M	Front seats "Blue 95" (Qty 2) PMV		52.976	49.21
O	F879 10M	Front seats "Ficelle 95" (Qty 2) PMV		52.976	49.21

SECTION 6
WEIGHT AND BALANCE

SOCATA
MODEL TB 10

S/ R/ A/ O	ITEM OPT10	REQUIRED (R) OR STANDARD (S) OR OPTIONAL (A or O) EQUIPMENT	*	WEIGHT per unit lb (kg)	ARM in. (m)
O	067900 M	Front seats "Cendre" (Qty 2) with head-rests (067915 M)		45.194	49.21
O	067910 M	Front seats "Sable" (Qty 2) with head-rests (067925M)		45.194	49.21
O	067940 M	Front seats "Blue 95" (Qty 2) PMV with head-rests (067935 M)		45.194	49.21
O	067950 M	Front seats "Ficelle 95" (Qty 2) PMV with head-rests (067945 M)		45.194	49.21
O	067980 M	Front seats "Blue 95" (Qty 2) PMV with head-rests (067935 M)		52.271	49.21
O	067990 M	Front seats "Ficelle 95" (Qty 2) PMV with head-rests (067945 M)		52.271	49.21
O	080000 M	L.H. or R.H. front seat back-off installation (Pre-MOD.89)		0.331	37.80
O	080010 M	L.H. front seat back-off installation (Post-MOD.89)		0.882	37.80
O	080020 M	R.H. front seat back-off installation (Post-MOD.89)		0.882	37.80
		25-12 - Rear bench			
R		Rear seat : Back + seating TB10 74027		13.448	84.65
R		Rear seat : Back + seating TB10 74107		14.616	84.65
O	F879 20M	Rear seat "Blue 95" PMV		18.144	84.65
O	F879 30M	Rear seat "Ficelle 95" PMV		18.144	84.65
O	F899 00M	Rear bench "Blue 95" with arm-rest "LUXE" (Post-MOD.90)		15.939	84.65
O	F899 10M	Rear bench "Ficelle 95" with arm-rest "LUXE" (Post-MOD.90)		15.939	84.65
O	067920 M	Rear seat "Cendre" with head-rests (067915 M)		17.064	84.65
O	067930 M	Rear seat "Sable" with head-rests (067925 M)		17.064	84.65

S/ R/ A/ O	ITEM OPT10	REQUIRED (R) OR STANDARD (S) OR OPTIONAL (A or O) EQUIPMENT	*	WEIGHT per unit lb (kg)	ARM in. (m)
O	067960 M	Rear seat "Blue 95" PMV with head-rests (067935 M)		17.064	84.65
O	067970 M	Rear seat "Ficelle 95" PMV with head-rests (067945 M)		17.064	84.65
O	079900 M	Rear seat "Cendre" with central arm-rest		13.338	84.65
O	079910 M	Rear seat "Sable" with central arm-rest		13.338	84.65
O	079920 M	Rear seat "Blue 95" PMV with central arm-rest		13.338	84.65
O	079930 M	Rear seat "Ficelle 95" PMV with central arm-rest		13.338	84.65
		25-13 - Safety and harnesses belts			
R		Front seat belt TB10 79013 SECURAIGLON		2.646	47.24
R		Front seat belt TB10 79013 TRW REPA		2.646	47.24
R		Front seat belt TB10 79013 P/N 10.4022.000.002 ANJOU AERO		2.646	47.24
R		Rear seat belt TB10 79014 P/N 344.22.070.04.300 AIGLON		1.124	94.49
A	050210 M	3rd rear safety belt "Black"		0.882	84.65
O	056320 M	Rear reel safety belt		2.646	106.30
A	063700 M	Rear seat shoulder harness (Qty 2)		2.249	94.49
A	064000 M	3rd rear reel safety belt		1.918	106.30
A	064100 M	3rd rear seat shoulder harness		1.124	94.49
		25-14 - Central pedestal			
S		Lighter R.V.I : - Plug 5000 361 037 R.V.I - Fixed part 5000 361 635 R.V.I - Light 5000 462 170 R.V.I		0.154	37.80

SECTION 6
WEIGHT AND BALANCE

SOCATA
MODEL TB 10

S/ R/ A/ O	ITEM OPT10	REQUIRED (R) OR STANDARD (S) OR OPTIONAL (A or O) EQUIPMENT	*	WEIGHT per unit lb (kg)	ARM in. (m)
S		Front ash-tray		0.882	43.31
S		Rear ash-tray		0.353	65.35
		25-15 - Upper duct			
A	052630 M	Sun visor PLEXIGLAS - Model 86		0.683	41.34
A	052640 M	Sun visor PLEXIGLAS - Model 91		0.683	41.34
		25-17 - Instrument panel			
O	057730 M	R.H. large instrument panel		4.740	23.62
O	057740 M	R.H. large instrument panel		4.740	23.62
		25-60 - Emergency equipment			
A	F902 00M	Axe		2.535	37.40
A	F903 00M	Life jackets (Qty 4)		8.818	124.80
A	H881 00M	First aid case		4.409	90.95
		25-61 - Emergency locator transmitter			
A	25-001A	Emergency locator transmitter ELT 91 SOCATA P/N ELT 91A 2560 000 000 (TSO)		3.351	103.15
A	J908 00M	Three-frequency emergency locator transmitter ELT 96 SOCATA (EUROCAE)		3.638	106.30
A	J924 00M	Emergency locator transmitter ELT 90 SOCATA (EUROCAE)		3.351	103.15
A	J931 00M	Emergency locator transmitter ELT 200 ARTEX (For export only)		2.866	103.15
A	J931 50M	Provisions assy for ELT 200 ARTEX (For export only)		0.220	103.15
A	J933 00M	Three-frequency emergency locator transmitter ELT 97 SOCATA (TSO)		3.638	106.30

S/ R/ A/ O	ITEM OPT10	REQUIRED (R) OR STANDARD (S) OR OPTIONAL (A or O) EQUIPMENT	*	WEIGHT per unit lb (kg)	ARM in. (m)
A	051700 M	Emergency locator transmitter ELT 10 NARCO		3.307	119.29
A	051710 M	Emergency locator transmitter JOLLIET (aft baggage compartment)		3.086	119.29
A	051730 M	Emergency locator transmitter JE2 NG JOLLIET (forward baggage compartment)		3.086	109.45

S/ R/ A/ O	ITEM OPT10	REQUIRED (R) OR STANDARD (S) OR OPTIONAL (A or O) EQUIPMENT	*	WEIGHT per unit lb (kg)	ARM in. (m)
26 - FIRE PROTECTION					
A	F823 00M	Cabin halon extinguisher FH 15N AREOFEU		4.409	37.80
A	F823 10M	Cabin halon extinguisher H1-10 AIR MAIP		4.850	37.80
A	F823 20M	Cabin halon extinguisher H1-10 AIR MAIP (with special support)		5.313	37.80
A	F823 30M	Cabin halon extinguisher L'HOTELLIER		3.638	37.68
A	F883 00M	Cabin powder extinguisher AFT 15N AREOFEU		4.608	37.80
A	052800 M	Cabin fire extinguisher		2.822	36.22

S/ R/ A/ O	ITEM OPT10	REQUIRED (R) OR STANDARD (S) OR OPTIONAL (A or O) EQUIPMENT	*	WEIGHT per unit lb (kg)	ARM in. (m)
		27 - FLIGHT CONTROLS			
		27-20 - Yaw control			
A	059700 M	Yaw, roll controls interconnection		2.138	16.14
		27-50 - Wing flaps (control)			
R		Flaps actuator TB10 61235 P/N 8375 AVIAC		5.071	61.81
R		Flaps actuator TB10 61235 P/N 700-239 LPMI		4.365	61.81
R		Flaps actuator TB10 61237 P/N 8308 AVIAC		5.534	61.81
O	C569 00M	Flaps preselection		0.220	39.37
O	C569 10M	Flaps preselection (with new switch)		0.220	39.37

S/ R/ A/ O	ITEM OPT10	REQUIRED (R) OR STANDARD (S) OR OPTIONAL (A or O) EQUIPMENT	*	WEIGHT per unit lb (kg)	ARM in. (m)
		28 - FUEL SYSTEM			
		28-10 - Fuel tanks			
A	058030 M	Ferry fuel tank (TB20 52925)		63.933	78.35
A	058040 M	Ferry fuel tank (TB20 52925)		63.933	78.35
		28-20 - Fuel supply			
R		Fuel electric pump TB10 61218000 P/N 476284 FACET/BENDIX or P/N 476284E FACET (PUROLATOR)		1.653 1.587	- 0.79 - 0.79
R		Fuel selector/filter TB20 52026		1.301	44.49
		28-40 - Fuel indication			
O	C866 00M	Fuel low level warning		0.728	33.46

S/ R/ A/ O	ITEM OPT10	REQUIRED (R) OR STANDARD (S) OR OPTIONAL (A or O) EQUIPMENT	* WEIGHT per unit lb (kg)	ARM in. (m)
		31 - INDICATING/RECORDING SYSTEMS		
		31-10 - Control and indicating panels		
R		Engine and fuel controls TB10 76201	1.102	24.80
O	F634 00M	Raised radio console	3.131	23.62
		31-20 - Independent instruments		
A	D516 00M	Stop watch DODANE	0.441	35.43
A	D571 00M	Hourmeter DATCON	0.551	23.62
A	D638 00M	Digital chronometer (L.H. station) ASTROTECH	0.507	35.43
A	D638 10M	Digital chronometer (R.H. station) ASTROTECH	0.507	35.43
A	D638 20M	Digital chronometer (R.H. station) ASTROTECH	0.507	35.43
A	D680 00M	Quartz chronometer THOMMEN (60 minutes elapsed time indicator) P/N Q18.945.22.28.1KB or Q18.945.22.28.1ME	0.485	35.43
A	D680 10M	Quartz chronometer THOMMEN (60 minutes elapsed time indicator) P/N Q18.945.22.28.1KB or Q18.945.22.28.1ME (R.H. station)	0.485	35.43
A	D680 20M	Quartz chronometer THOMMEN (60 minutes elapsed time indicator) P/N Q18.945.22.28.1KB or Q18.945.22.28.1ME	0.485	35.43
A	D680 30M	Quartz chronometer THOMMEN (12 minutes elapsed time indicator) P/N Q18.948.22.28.1ME	0.485	35.43
A	D806 00M	Three-axis accelerometer	0.992	23.62
A	D829 00M	Mechanical chronometer THOMMEN P/N B18.945.22.28.1K	0.485	35.43

S/ R/ A/ O	ITEM OPT10	REQUIRED (R) OR STANDARD (S) OR OPTIONAL (A or O) EQUIPMENT	*	WEIGHT per unit lb (kg)	ARM in. (m)
A	D829 10M	Mechanical chronometer THOMMEN P/N B18.945.22.28.1K (R.H. station)		0.485	35.43
A	D833 00M	Digital clock/chronometer LC2 ASTROTECH		0.331	23.62
A	D844 00M	Mechanical chronometer Type 11.1 BREGUET		0.441	35.43
O	D911 00M	Hourmeter "Flight duration" DATCON NOTE : Tachometer-Hourmeter, refer to ATA 77		0.661	31.50
		31-50 - Central warning systems			
R		Advisory panel TB20 61222 (if GPS installed, refer to ATA 34)		0.397	22.83
A	C561 00M	Starter warning light		0.132	39.37
O	C900 00M	Advisory panel (extended) (Not valid for U.K. aircraft)		0.529	23.62

S/ R/ A/ O	ITEM OPT10	REQUIRED (R) OR STANDARD (S) OR OPTIONAL (A or O) EQUIPMENT	*	WEIGHT per unit lb (kg)	ARM in. (m)
		32 - LANDING GEARS			
		32-10 - Main landing gear			
S		L.H. fairing TB10 48012006		11.905	62.20
S		R.H. fairing TB10 48012007		11.905	62.20
		32-20 - Nose landing gear			
S		Front fairing TB10 48014004 Rear fairing TB10 48014005		6.173	- 10.24
O	052500 M	Airplane without LDG fairings		- 29.983	47.24
		32-40 - Wheels and brakes			
R		Main LDG wheel assy (2) 40-97E Type III CLEVELAND		5.842	59.84
R		Main LDG wheel assy (2) 40-97F CLEVELAND		6.482	59.84
R		Main LDG brake assy (2) 91.50 CLEVELAND		1.918	59.84
R		Main LDG tire (2) 6.00-6 6 PLYS GOODYEAR (Pre-MOD.118 or MOD.120)		8.818	59.84
R		Main LDG tire (2) 6.00-6 6 PR TT DUNLOP (Pre-MOD.118 or MOD.120)		8.818	59.84
R		Main LDG tire (2) 6.00-6 6 PR P/N 606C61.6 GOODYEAR (Post-MOD.118 or MOD.120)		8.818	59.84
R		Main LDG tire (2) 6.00-6 6 120TT MICHELIN (Post-MOD.118 or MOD.120)		8.818	59.84
R		Main LDG tube (2) 6.00-6 DUNLOP (Pre-MOD.118 or MOD.120)		1.653	59.84
R		Main LDG tube (2) P/N 092-315-0 MICHELIN (Post-MOD.118 or MOD.120)		2.425	59.84
R		Main LDG tube (2) 15.6.00-6 TR GOODYEAR (Post-MOD.118 or MOD.120)		1.653	59.84
R		Nose LDG wheel assy 40-77 B CLEVELAND		2.822	- 16.93

SECTION 6
WEIGHT AND BALANCE

SOCATA
MODEL TB 10

S/ R/ A/ O	ITEM OPT10	REQUIRED (R) OR STANDARD (S) OR OPTIONAL (A or O) EQUIPMENT	*	WEIGHT per unit lb (kg)	ARM in. (m)
R		Nose LDG tire 5.00-5 6 PRTT DUNLOP		6.393 or 5.798	- 16.93
R		Nose LDG tire 5.00-5 6 120TT MICHELIN		6.393	- 16.93
R		Nose LDG tire 5.00-5 6 120TT AVIATOR		5.489	- 16.93
R		Nose LDG tire 5.00-5 6 PR P/N 505C61.8 GOODYEAR		5.291	- 16.93
R		Nose LDG tube 5.00-5 DUNLOP		1.455	- 16.93
R		Nose LDG tube TR67A P/N 092-308-0 MICHELIN		1.455	- 16.93
R		Nose LDG tube 5.00-5 TR67 GOODYEAR		1.455	- 16.93
A	052100 M	Braking control (R.H. post)		3.307	11.81
		32-60 - Position indicating system and alarms			
A	B877 00M	LDG simulator assy		0.595	23.62

S/ R/ A/ O	ITEM OPT10	REQUIRED (R) OR STANDARD (S) OR OPTIONAL (A or O) EQUIPMENT	* WEIGHT per unit lb (kg)	ARM in. (m)
		33 - LIGHTS		
		33-10 - Cockpit		
S		Rear cabin lighting TB20 64200	0.507	65.35
S		Instrument panel lighting TB20 64201	0.485	23.62
S		Front cabin lighting (emerg.) TB20 64200	0.220	44.09
A	E588 00M	Maps reading light	0.176	25.59
A	E873 00M	Emergency lighting system	4.079	104.72
		33-40 - External lighting		
S		Landing light G.E. 4591	0.353	35.43
S		Taxi light G.E. 4626	0.353	35.43
S		L.H. navigation light 3131 LABINAL	0.198	34.65
S		R.H. navigation light 3133 LABINAL	0.198	34.65
S		L.H. navigation light W1250 PR WHELEN	0.198	34.65
S		R.H. navigation light W1250 PG WHELEN	0.198	34.65
S		Rear navigation light 3175 LABINAL	0.154	239.76
S		Rear navigation light A555A-V-28V WHELEN	0.132	239.76
A	E537 00M	Strobe light JPC on vertical stabilizer	1.874	145.67
A	E537 10M	Strobe lights JPC on vertical stabilizer and under fuselage	3.197	140.55
A	E537 20M	Strobe light JPC on vertical stabilizer (red glass)	1.874	145.67
A	E824 00M	Anticollision lights WHELEN (wing tips) A490A TS DF 14-28 - Light A625	5.423	107.48

SECTION 6
WEIGHT AND BALANCE

SOCATA
MODEL TB 10

S/ R/ A/ O	ITEM OPT10	REQUIRED (R) OR STANDARD (S) OR OPTIONAL (A or O) EQUIPMENT	*	WEIGHT per unit lb (kg)	ARM in. (m)
A	E824 10M	Anticollision lights WHELEN (wing tips) A490A TS CF 14-28 - Light A625		5.423	107.48
A	E824 20M	Anticollision lights WHELEN (wing tips) A490A TS DF 14-28 - Light A625D		5.423	107.48
A	E824 30M	Anticollision lights WHELEN (wing tips) A490A TS CF 14-28 - Light A625D		5.423	107.48
A	E824 40M	Anticollision lights WHELEN (wing tips) A490A TS CF 14-28 - Light A625 P/N 01-077058-15		5.423	107.48
O	E826 00M	Strobe light WHELEN (tail) A490A TS DF 14-28 - Light A500 ASP		2.094	145.67
O	E826 10M	Strobe light WHELEN (tail) A490A TS CF 14-28 - Light A500 SP		2.094	145.67
O	E826 20M	Strobe light WHELEN (tail) A490A TS CF 14-28 - Light A500A		2.094	145.67
O	E848 00M	Light control box JX 128 FLASHELEK		0.551	55.31

S/ R/ A/ O	ITEM OPT10	REQUIRED (R) OR STANDARD (S) OR OPTIONAL (A or O) EQUIPMENT	* WEIGHT per unit lb (kg)	ARM in. (m)
		34 - NAVIGATION		
		34-10 - Flight environment data		
		34-11 - Air data systems		
R		Altimeter TB20 76222 P/N 5934 PD3 Code A253 UNITED INSTRUMENTS	0.816	25.59
R		True airspeed indicator with integrated lighting TB10 76223 P/N 8100 Code B603 UNITED INSTRUMENTS	0.728	24.80
R		True airspeed indicator with integrated lighting T200 76003 P/N 8100 Code B675 UNITED INSTRUMENTS	0.728	24.80
O	C515 10M	Heated pitot (Not valid for Russian & Ukrainian aircraft)	1.190	53.15
A	C635 00M	2nd heated pitot (R.H. wing)	1.190	47.24
A	D681 00M	2nd altimeter 20000 ft	1.433	19.69
A	D682 00M	Vertical speed indicator with integrated lighting P/N 7000 Code C83 UNITED INSTRUMENTS	1.014	23.62
A	D803 10M	Installation of 2nd airspeed indicator	1.213	23.62
A	D811 00M	Alti-coder KE 127 KING	1.433	17.72
A	D830 00M	Alti-coder 20000 ft TRANSCALL	1.433	17.72
A	D831 00M	Alti-coder 30000 ft TRANSCALL	1.433	17.72
A	D832 00M	2nd altimeter 35000 ft	1.433	19.69
A	D897 00M	2nd vertical speed indicator (R.H. station) P/N 7000 C83 UNITED INSTRUMENTS	1.521	23.62
A	D915 00M	Metric altimeter # 3 P/N 5940 UNITED INSTRUMENTS	0.926	23.62
O	K608 20M	Alti-coder KEA 130A (35000 ft) KING	1.764	21.65

SECTION 6
WEIGHT AND BALANCE

SOCATA
MODEL TB 10

S/ R/ A/ O	ITEM OPT10	REQUIRED (R) OR STANDARD (S) OR OPTIONAL (A or O) EQUIPMENT	*	WEIGHT per unit lb (kg)	ARM in. (m)
O	K608 30M	Alti-coder 20000 ft UNITED INSTRUMENTS		1.764	21.65
A	N846 00M	Altitude encoder AR850 NARCO		1.323	19.69
A	051100 M	Alternate static source (in cabin)		0.331	23.62
		34-13 - Outside temperature			
A	D804 00M	Outside air temperature indicator (standard connector on sensor)		0.551	23.62
A	D804 10M	Outside air temperature indicator (water-tight connector on sensor)		0.551	23.62
A	D804 20M	Outside air temperature indicator (water-tight connector on sensor) (OPT10 D804 10M retrofit)		0.551	23.62
A	D910 00M	Outside air temperature indicator (standard connector on sensor) DAVTRON		0.551	23.62
A	D910 10M	Outside air temperature indicator (water-tight connector on sensor) DAVTRON		0.551	23.62
A	D910 20M	Outside air temperature indicator (water-tight connector on sensor) DAVTRON		0.551	23.62
		34-20 - Attitude and direction			
		34-21 - Heading reference system			
A	34-302A	HSI assy KCS 55A HONEYWELL		12.721	67.32
A	D683 40M	Air-driven heading indicator AID		2.888	21.65
A	D914 00M	Heading gyro indicator SIGMA-TEK (on L.H. instrument panel)		2.668	23.62
A	D914 10M	Heading gyro indicator SIGMA-TEK (on R.H. instrument panel)		2.976	19.69
A	D922 00M	Electric heading gyro indicator 205-1BL		3.219	23.62
A	K660 00M	HSI assy KING without heading recopy		12.720	67.32

S/ R/ A/ O	ITEM OPT10	REQUIRED (R) OR STANDARD (S) OR OPTIONAL (A or O) EQUIPMENT	*	WEIGHT per unit lb (kg)	ARM in. (m)
A	K660 10M	HSI assy KING with heading recopy capability		12.720	67.32
A	K660 20M	HSI assy KING with heading recopy capability (30/400 Hz) with vertical KA 51B		12.720	67.32
A	K660 30M	HSI assy KING with heading recopy capability (30/400 Hz) with horizontal KA 51B		12.720	67.32
A	K660 40M	HSI assy KING with heading recopy capability (30/400 Hz) (lighting control at R.H. station)		12.720	67.32
A	K660 50M	HSI assy KING with horizontal KA 51B (if GPS KLN 90B installed)		12.720	67.32
A	K660 60M	HSI assy KING with vertical KA 51B (if GPS KLN 90B installed)		12.720	67.32
A	067140 M	Heading indicator KG 107		2.690	20.47
		34-22 - Turn and bank indication			
R		Slip indicator Type 57 AIR PRECISION		0.110	23.62
R		Slip indicator P/N 35216 WINTER		0.110	23.62
O	34-002A	Electrical turn coordinator UNITED INSTRUMENTS		1.323	23.62
O	D691 00M	Turn-and-bank indicator UNITED INSTRUMENTS		1.675	23.62
O	D697 00M	Electrical turn coordinator CASTLEBERRY		1.698	23.62
A	D818 10M	Slip indicator (R.H. station) UNITED INSTRUMENTS		1.675	23.62
		34-23 - Magnetic compass			
R		Compass TB20 76229 P/N C2400 L 4P (28 V) AIRPATH		0.595	20.47
		34-24 - ADI and standby horizon			
A	34-001A	Electrical attitude gyro indicator 1100-28L(5F) BFG (Not valid for U.K. aircraft)		2.866	24.41

SECTION 6
WEIGHT AND BALANCE

SOCATA
MODEL TB 10

S/ R/ A/ O	ITEM OPT10	REQUIRED (R) OR STANDARD (S) OR OPTIONAL (A or O) EQUIPMENT	*	WEIGHT per unit lb (kg)	ARM in. (m)
A	34-001C	Electrical attitude gyro indicator 1100-28LS(5F) BFG (on L.H. instrument panel) (Not valid for U.K. aircraft)		2.866	24.41
A	34-001D	Electrical attitude gyro indicator 1100-28LS(5F) BFG (on L.H. instrument panel) (Not valid for U.K. aircraft)		2.866	24.41
A	D683 00M	Attitude gyro and heading gyro indicators AID (Not valid for U.K. aircraft)		5.093	21.65
A	D683 20M	Attitude gyro indicator AID (Not valid for U.K. aircraft)		2.205	21.65
A	D802 00M	Electrical attitude gyro indicator 305-2BL (on L.H. instrument panel) (Not valid for U.K. aircraft)		2.690	23.62
A	D802 10M	Electrical attitude gyro indicator 305-2BL-S (Not valid for U.K. aircraft)		2.690	23.62
A	D802 20M	Electrical attitude gyro indicator 305-2BL-S (Not valid for U.K. aircraft)		2.690	23.62
A	D802 40M	Electrical attitude gyro indicator 305-2BL (on R.H. instrument panel) (Not valid for U.K. aircraft)		2.690	23.62
A	D802 60M	Electrical attitude gyro indicator B305-2BL (on R.H. instrument panel) (Not valid for U.K. aircraft)		2.690	23.62
A	D867 00M	Electric attitude gyro indicator RCA26 BK-12 (R.H. seat) RC ALLEN (Not valid for U.K. aircraft)		2.315	21.65
A	D913 00M	Attitude gyro indicator SIGMA-TEK (Not valid for U.K. aircraft)		2.161	23.62
A	067130 M	Attitude gyro indicator KG 258 for KAP 100 (Not valid for U.K. aircraft)		3.086	20.47
A	067230 M	Attitude gyro indicator KG 258 for KAP 150 (Not valid for U.K. aircraft)		3.086	20.47
A	067330 M	Attitude gyro indicator with Flight Director KI 256 for KFC 150		3.285	20.47

S/ R/ A/ O	ITEM OPT10	REQUIRED (R) OR STANDARD (S) OR OPTIONAL (A or O) EQUIPMENT	*	WEIGHT per unit lb (kg)	ARM in. (m)
		34-25 - Radio magnetic indication			
A	K584 00M	RMI KI 22900 (without switching) KING		3.086	21.65
A	K584 10M	RMI KI 22900 (with switching) KING		3.307	21.65
A	K819 00M	RMI KNI 582 KING		3.417	21.65
		34-30 - Landing and taxiing aids			
		34-31 - Marker			
A	K676 00M	Marker receiver indicator KR 21 KING		1.257	21.65
		34-40 - Independent position determining			
		34-41 - Stormscope			
A	34-502A	Stormscope WX 500 BFG		4.960	117.32
A	J820 00M	Stormscope WX 1000 BFG (on panel strip)		15.432	83.07
A	J820 10M	Stormscope WX 1000 BFG (on R.H. instrument panel)		15.432	83.07
A	J828 00M	Stormscope WX 1000 + BFG		15.432	83.07
A	J828 10M	Stormscope WX 1000 + BFG (with converter assy)		15.432	83.07
A	J918 00M	Stormscope WX-900 BFG		4.806	85.43
		34-50 - Dependent position determining			
		34-51 - NAV 1 installation			
A	K654 00M	Receiver VOR KN 53 NAV 1 VOR/ILS KING		5.026	68.11
A	K654 10M	Receiver VOR KN 53 NAV 1 VOR/LOC KING		6.790	55.12
A	K662 00M	NAV system KNS 81-10 KING		7.496	52.76

SECTION 6
WEIGHT AND BALANCE

SOCATA
MODEL TB 10

S/ R/ A/ O	ITEM OPT10	REQUIRED (R) OR STANDARD (S) OR OPTIONAL (A or O) EQUIPMENT	*	WEIGHT per unit lb (kg)	ARM in. (m)
A	K662 20M	NAV system KNS 81-12 KING		7.496	52.76
A	K663 00M	VHF assy COM1/NAV1 (VOR/LOC) KX 155 with audio amplifier (with VHF capability) KING		11.486	35.43
A	K663 10M	VHF assy COM1/NAV1 (VOR/ILS) KX 155 (with VHF capability) KING		11.596	48.82
A	K663 40M	VHF assy COM1/NAV1 (VOR/LOC) KX 155 (with VHF capability) KING		11.486	35.43
A	K663 50M	VHF assy COM1/NAV1 (VOR/LOC) KX 155 (without VHF capability) KING		8.091	30.71
A	K663 60M	VHF assy COM1/NAV1 (VOR/ILS) KX 155 (without VHF capability) KING		8.201	49.21
A	K663 70M	VHF assy COM1/NAV1 (VOR/LOC) KX 155 with audio amplifier (without VHF capability) KING		8.091	30.71
A	K666 00M	VHF 1 VOR/LOC KX165-25 KING		12.566	39.37
A	K666 10M	VHF 1 VOR/ILS KX165-25 KING		14.087	35.43
A	K667 00M	NAV system KNS 80 KING		8.598	54.33
A	K812 00M	VHF assy COM1/NAV1 (VOR/ILS) KX 165 (with VHF capability) KING		11.118	49.61
A	K812 20M	VHF assy COM1/NAV1 (VOR/LOC) KX 165 (with VHF capability) KING		11.552	35.43
A	K812 50M	VHF assy COM1/NAV1 (VOR/LOC) KX 165 (without VHF capability) KING		8.157	30.71
A	K812 60M	VHF assy COM1/NAV1 (VOR/ILS) KX 165 (without VHF capability) KING		7.782	50.39
A	K813 00M	VOR/ILS indicator KI 206-04 KING		1.631	21.65
A	K813 10M	VOR/ILS indicator KI 206-05 KING		1.764	21.65
A	K814 00M	VOR/ILS indicator KI 204 KING		1.918	21.65
A	K847 00M	Converter VOR/LOC KN 72 KING		1.653	43.31

S/ R/ A/ O	ITEM OPT10	REQUIRED (R) OR STANDARD (S) OR OPTIONAL (A or O) EQUIPMENT	*	WEIGHT per unit lb (kg)	ARM in. (m)
34-52 - NAV 2 installation					
A	K654 20M	Receiver VOR KN 53 NAV 2 VOR/ILS KING		5.379	63.78
A	K654 30M	Receiver VOR KN 53 NAV 2 VOR/LOC KING		6.967	59.05
A	K663 20M	VHF assy COM2/NAV2 (VOR/LOC) KX 155 KING		7.760	24.80
A	K663 30M	VHF assy COM2/NAV2 (VOR/ILS) KX 155 KING		6.900	24.80
A	K666 20M	VHF 2 VOR/LOC KX165-25 KING		5.335	39.37
A	K666 30M	VHF 2 VOR/ILS KX165-25 KING		8.818	48.82
A	K812 10M	VHF assy COM2/NAV2 (VOR/ILS) KX 165 KING		6.482	24.80
A	K812 30M	VHF assy COM2/NAV2 (VOR/LOC) KX 165 KING		7.716	24.80
A	K813 00M	VOR/ILS indicator KI 206-04 KING		1.631	21.65
A	K813 10M	VOR/ILS indicator KI 206-05 KING		1.764	21.65
A	K814 00M	VOR/ILS indicator KI 204 KING		1.918	21.65
34-53 - Transponder					
A	34-501A	Transponder GTX 320 GARMIN		3.086	29.53
A	34-504A	Transponder GTX 327 GARMIN		3.968	21.65
A	K656 00M	ATC KT 76 A KING on radio console		3.682	20.08
A	K656 20M	ATC KT 76 A KING on R.H. panel strip (with support)		3.836	21.65
A	K876 00M	Transponder ATC KT 71 KING		4.630	22.44
A	K876 10M	Transponder ATC KT 71 KING (on R.H. panel strip)		4.630	22.44
A	K929 00M	Transponder ATC KT 76C KING (on R.H. panel strip)		3.527	23.62

S/ R/ A/ O	ITEM OPT10	REQUIRED (R) OR STANDARD (S) OR OPTIONAL (A or O) EQUIPMENT	*	WEIGHT per unit lb (kg)	ARM in. (m)
34-54 - Automatic Direction Finder (ADF)					
A	34-300A	ADF assy KR 87 SC+ (Indicator KI 227.01) HONEYWELL		8.885	90.16
A	34-300B	ADF assy KR 87 SC+ (Indicator KI 227.00) HONEYWELL		8.885	90.16
A	34-300C	ADF assy KR 87 SC+ (Indicator KI 229) HONEYWELL		11.045	76.77
A	34-300D	ADF assy KR 87 SC+ (Indicator KNI 582) HONEYWELL		11.177	76.77
A	K655 00M	ADF KR 87.01/04 (Indicator KI 227.00) KING (on radio console)		8.730	90.16
A	K655 10M	ADF KR 87.01/04 (Indicator KI 227.01) KING (on radio console)		8.730	90.16
A	K655 20M	ADF KR 87 KING		8.025	96.06
A	K655 40M	ADF KR 87 (Indicator KI 227.01) KING (on R.H. panel strip)		8.730	90.16
A	K917 00M	ADF2 KR 87 KING		9.436	94.49
34-55 - DME installation					
A	34-305A	DME KN 62A SC+ HONEYWELL		3.527	30.71
A	K657 00M	DME KN 62A KING		3.682	21.26
A	K657 10M	DME KN 64 KING		3.682	21.26
A	K664 00M	DME KN 63 KING		5.489	40.94
34-57 - Global Positioning System (GPS)					
A	34-500A	Color Skymap capability CM 2000 SKYFORCE		0.970	30.51
A	J870 00M	GPS 100 AVD-140 GARMIN interfaced with HSI and A/P (VFR use only), including advisory panel TB20 61760 (For export only)		4.145	22.44

S/ R/ A/ O	ITEM OPT10	REQUIRED (R) OR STANDARD (S) OR OPTIONAL (A or O) EQUIPMENT	*	WEIGHT per unit lb (kg)	ARM in. (m)
A	J870 10M	GPS 100 AVD-140 GARMIN "Stand alone"		3.593	22.44
A	J870 20M	GPS 100 AVD-140 GARMIN "Stand alone", with audio attenuation, including extended advisory panel		3.593	22.44
A	J870 30M	GPS 100 AVD-140 GARMIN interfaced with HSI and A/P, with audio attenuation (VFR use only), including advisory panel (For export only)		4.145	22.44
A	J870 40M	GPS 100 AVD-140 GARMIN interfaced with HSI, with audio attenuation (VFR use only), including advisory panel (For export only)		4.145	22.44
A	J925 00M	GPS 150 GARMIN "Stand alone"		4.696	25.60
A	K860 00M	GPS KLN 90A KING "Stand alone"		8.466	22.44
A	K860 10M	GPS KLN 90A KING interfaced with HSI and A/P, with RMI		9.171	21.65
A	K860 20M	GPS KLN 90A KING "Stand alone" with extended advisory panel		8.466	22.44
A	K860 30M	GPS KLN 90A KING interfaced with HSI, with RMI		9.171	21.65
A	K860 40M	GPS KLN 90A KING interfaced with HSI and A/P, without RMI (For export only)		9.171	21.65
A	K899 00M	GPS KLN 90B KING interfaced with HSI and A/P, without RMI (KA91 antenna) (For export only)		9.943	21.26
A	K899 10M	GPS KLN 90B KING interfaced with HSI and A/P, without RMI (KA92 antenna) (For export only)		9.943	21.26

SECTION 6
WEIGHT AND BALANCE

SOCATA
MODEL TB 10

S/ R/ A/ O	ITEM OPT10	REQUIRED (R) OR STANDARD (S) OR OPTIONAL (A or O) EQUIPMENT	*	WEIGHT per unit lb (kg)	ARM in. (m)
A	K899 30M	GPS KLN 90B KING interfaced with HSI and A/P, with RMI (KA92 antenna) (English-speaking countries)		9.943	21.26
A	K920 00M	GPS KLN 89B KING "Stand alone"		4.519	25.20
A	K926 00M	GPS KLN 89B KING interfaced with HSI KI 525A (KCS 55A compass system)		5.578	22.83
A	K927 00M	GPS KLN 90B KING interfaced with HSI and A/P, without RMI (KA92 antenna)		9.943	21.26
		34-60 - Flight management computing			
		34-62 - Multifunction display			
A	34-304A	MFD KMD 550 HONEYWELL		6.614	21.65

S/ R/ A/ O	ITEM OPT10	REQUIRED (R) OR STANDARD (S) OR OPTIONAL (A or O) EQUIPMENT	*	WEIGHT per unit lb (kg)	ARM in. (m)
		37 - VACUUM			
		37-11 - Distribution (normal)			
A	A816 00M	Vacuum system with : Pump AIRBORNE 211CC or Pump AIRBORNE 215CC or Pump CHAMPION CH215CC (with AIRBORNE filter) or Pump AERO ACCESSORIES AA215CC (with AIRBORNE filter)		4.784 2.205 3.285 3.285	0 0 - 15.75 - 15.75
A	A904 00M	Vacuum pump SIGMA-TEK (with filter)		5.225	- 3.54
A	A904 10M	Vacuum pump SIGMA-TEK (with filter) (when stormscope installed, refer to ATA 34)		5.225	- 3.54
A	067150 M	Vacuum system (without attitude gyro indicator, nor heading, nor HSI)		2.579	10.24
		37-12 - Distribution (emergency)			
A	C632 00M	Auxiliary dry air pump		12.456	30.31
		37-20 - Indicating			
A	063100 M	Vacuum system warning light		0.198	0.39

S/ R/ A/ O	ITEM OPT10	REQUIRED (R) OR STANDARD (S) OR OPTIONAL (A or O) EQUIPMENT	*	WEIGHT per unit lb (kg)	ARM in. (m)
		52 - DOORS 52-10 - Access doors			
A	H889 00M	Door stop system (metallic doors)		1.653	49.21

S/ R/ A/ O	ITEM OPT10	REQUIRED (R) OR STANDARD (S) OR OPTIONAL (A or O) EQUIPMENT	*	WEIGHT per unit lb (kg)	ARM in. (m)
A	B896 00M	<p>53 - FUSELAGE</p> <p>Tail cone protection</p>		0.661	215.67

S/ R/ A/ O	ITEM OPT10	REQUIRED (R) OR STANDARD (S) OR OPTIONAL (A or O) EQUIPMENT	*	WEIGHT per unit lb (kg)	ARM in. (m)
		56 - WINDOWS			
S		Colourless windows assy : - Windshield TB21 24001 - Door windows TB10 25030 - Rear side windows TB10 22030		27.558 11.023 8.598 7.937	53.15 27.56 55.12 86.61
O	058520 M	Tinted windows assy : - Windshield TB21 24001 - Door windows TB10 25030 - Rear side windows TB10 22030		27.558 11.023 8.598 7.937	53.15 27.56 55.12 86.61
A	056200 M	L.H. little window		0.750	39.37
A	056210 M	R.H. little window		0.750	39.37
A	056220 M	L.H. tinted little window		0.750	39.37
A	056230 M	R.H. tinted little window		0.750	39.37
A	F868 00M	Ventilation scoops		0.220	79.53

S/ R/ A/ O	ITEM OPT10	REQUIRED (R) OR STANDARD (S) OR OPTIONAL (A or O) EQUIPMENT	*	WEIGHT per unit lb (kg)	ARM in. (m)
R		61 - PROPELLER Propeller HC-C2YK-1BF/F 7666 A-2 HARTZELL		54.233	- 47.64
R		61-20 - Controls Propeller governor F4 HARTZELL		5.731	- 14.96

SECTION 6
WEIGHT AND BALANCE

SOCATA
MODEL TB 10

S/ R/ A/ O	ITEM OPT10	REQUIRED (R) OR STANDARD (S) OR OPTIONAL (A or O) EQUIPMENT	*	WEIGHT per unit lb (kg)	ARM in. (m)
R		72 - PISTON ENGINE Engine O-360-A1AD LYCOMING		287.70	- 27.95

S/ R/ A/ O	ITEM OPT10	REQUIRED (R) OR STANDARD (S) OR OPTIONAL (A or O) EQUIPMENT	*	WEIGHT per unit lb (kg)	ARM in. (m)
R		74 - IGNITION 74-10 - Electric generation system Dual magneto D4LN 3000 BENDIX		10.582	- 17.32

S/ R/ A/ O	ITEM OPT10	REQUIRED (R) OR STANDARD (S) OR OPTIONAL (A or O) EQUIPMENT	*	WEIGHT per unit lb (kg)	ARM in. (m)
		77 - ENGINE INDICATING			
		77-10 - Power			
R		Tachometer TB10 76206 P/N LM 82 LMI		1.014	25.59
R		Manifold pressure TB10 76224 P/N 6111 Code D73 UNITED INSTRUMENTS		0.948	25.59
O	D863 00M	Tachometer-Hourmeter NRF 80 LM 03 LMI		0.860	23.62
		77-20 - Temperature			
A	D536 00M	Exhaust gas temperature (EGT) ALCOR		0.882	21.65
A	D684 00M	Carburetor temperature		0.331	23.62
A	D684 10M	Carburetor temperature (without cover on R.H. instrument panel)		0.331	23.62
A	D685	EGT/CHT - Probe on all cylinders		3.307	3.94
A	D685 00M	EGT/CHT - Probe on cylinder No. 3		1.323	19.69

S/ R/ A/ O	ITEM OPT10	REQUIRED (R) OR STANDARD (S) OR OPTIONAL (A or O) EQUIPMENT	*	WEIGHT per unit lb (kg)	ARM in. (m)
A	A887 00M	<p>78 - EXHAUST</p> <p>Low noise exhaust</p>		15.432	15.75

S/ R/ A/ O	ITEM OPT10	REQUIRED (R) OR STANDARD (S) OR OPTIONAL (A or O) EQUIPMENT	*	WEIGHT per unit lb (kg)	ARM in. (m)
		79 - LUBRICATION			
		79-10 - Storage			
A	065810 M	Oil drain door		0.220	- 25.59
		79-20 - Distribution			
R		Oil cooler 20002A NDM		1.742	- 20.47

S/ R/ A/ O	ITEM OPT10	REQUIRED (R) OR STANDARD (S) OR OPTIONAL (A or O) EQUIPMENT	*	WEIGHT per unit lb (kg)	ARM in. (m)
		80 - STARTING			
R		Starter : - PRESTOLITE/ELECTROSYSTEMS MHB 4016 or MHB 6016 or - LYCOMING LW 15572 or 31B22474		17.990 8.091	- 39.37 - 37.40
R		Starter 31B 21064 LYCOMING		11.376	- 39.37
R		Starter relay CE 1971 060 F PARIS RHONE		1.499	- 1.18

INTENTIONALLY LEFT BLANK

S/ R/ A/ O	ITEM OPT10	REQUIRED (R) OR STANDARD (S) OR OPTIONAL (A or O) EQUIPMENT	*	WEIGHT per unit lb (kg)	ARM in. (m)
		01 - SPECIFIC OPTIONAL EQUIPMENT			
A	H615 20M	Additional equipment for IFR France "Grey"		/	/
A	H616 20M	Additional equipment for night VFR France "Grey"		0.441	25.59

SECTION 6
WEIGHT AND BALANCE

SOCATA
MODEL TB 10

S/ R/ A/ O	ITEM OPT10	REQUIRED (R) OR STANDARD (S) OR OPTIONAL (A or O) EQUIPMENT	*	WEIGHT per unit lb (kg)	ARM in. (m)
		21 - ENVIRONMENTAL SYSTEM			
		21-40 - Heating			
A	C869 20M	Radio console forced ventilation (blower KING KA 33)		1.543	12.99
A	F822 20M	Forced ventilation, rear passengers VETUS		2.756	136.61

S/ R/ A/ O	ITEM OPT10	REQUIRED (R) OR STANDARD (S) OR OPTIONAL (A or O) EQUIPMENT	*	WEIGHT per unit lb (kg)	ARM in. (m)
22 - AUTO FLIGHT					
22-12 - Autopilot					
A	D675 00M	Altitude and vertical speed preselector KAS 297B KING		1.764	21.65
A	D675 10M	Altitude and vertical speed preselector KAS 297B KING (on R.H. instrument panel)		1.764	21.65
A	D675 20M	Altitude and vertical speed preselector KAS 297B KING (on radio console)		1.764	21.65
A	G668 00M	A/P KAP 100 KING		11.442	35.43
A	G668 10M	A/P KAP 100 KING with electrical pitch trim		17.659	67.72
A	G669 00M	A/P KAP 150 KING		21.363	76.38
A	G670 00M	A/P KFC 150 KING		21.561	75.59
A	G810 00M	Remote A/P modes annunciator KA 185-03 for KAP 150		0.661	23.62
A	G810 10M	Remote A/P modes annunciator KA 185-01 for KFC 150		0.661	23.62

SECTION 6
WEIGHT AND BALANCE

SOCATA
MODEL TB 10

S/ R/ A/ O	ITEM OPT10	REQUIRED (R) OR STANDARD (S) OR OPTIONAL (A or O) EQUIPMENT	*	WEIGHT per unit lb (kg)	ARM in. (m)
		23 - COMMUNICATIONS			
		23-10 - Speech communications			
		23-11 - VHF capability			
S		VHF/COM capability TB10 65216 : - Loud-speaker - Hand microphone - Radio master switch		3.219	45.27
A	23-001A	Audio selector/Intercom system PMA 7000MS PS ENGINEERING (stereo wiring)		3.814	26.77
A	23-001B	Audio selector/Intercom system PMA 7000MS PS ENGINEERING (mono wiring)		3.814	26.77
A	23-002A	Audio selector/Intercom system GMA 340 GARMIN		4.189	27.56
A	34-503A	Boom microphone headset AHX-05 Serie X BOSE - Pilot - Front passenger		1.235 0.683	55.12 55.12
A	J912 00M	Boom microphone headset H10-13-4 DAVID CLARK		0.838	55.12
A	J928 00M	Boom microphone headset HMEC 25-KA SENNHEISER : Pilot and front passenger Rear passengers		0.661 0.661	55.12 94.49
A	J928 10M	Boom microphone headset HMEC 25-KAS SENNHEISER : Pilot and front passenger Rear passengers		0.661 0.661	55.12 94.49
A	K807 00M	Audio control box KMA 24H52 KING with interphone		2.205	27.56
A	K809 00M	Audio control box KMA 24H70 KING with audio selector threshold (4 transmitters/receivers)		2.381	31.50

S/ R/ A/ O	ITEM OPT10	REQUIRED (R) OR STANDARD (S) OR OPTIONAL (A or O) EQUIPMENT	*	WEIGHT per unit lb (kg)	ARM in. (m)
A	K809 10M	Audio control box KMA 24H71 KING with audio selector threshold (5 transmitters/receivers)		2.381	31.50
A	K815 10M	Audio selection box KMA 24-02 KING		2.910	22.44
A	052300 M	Boom microphone headset H10-30 DAVID CLARK		1.190	55.12
		23-12 - COM 1 installation			
S		Faired antenna VHF 1 DMC 70 1/A DORNE & MARGOLIN		0.661	127.17
A	23-003A	VHF COM/NAV GPS#1 GNS 430 GARMIN interfaced with GI 106A		9.700	24.80
A	23-005A	COM1/NAV1 KX 155A VOR/ILS HONEYWELL (KN 72 and HSI indicator)		6.945	26.38
A	23-005D	COM1/NAV1 KX 155A VOR/ILS HONEYWELL (KI 204 indicator)		7.518	22.44
A	23-006A	COM1/NAV1/GPS1 GNS 430 #1 GARMIN interfaced with HSI		8.157	25.59
A	23-007A	COM1/NAV1/GPS1 GNS 530 GARMIN interfaced with HSI		10.141	23.23
A	K805	VHF 1 KY 196 A 30 KING		3.858	18.11
A	054910 M	VHF 1 faired antenna DMC 70 1/AX DORNE & MARGOLIN		0.661	127.32
		23-13 - COM 2 installation			
A	23-004	COM2/NAV2/GPS2 GNS 430 #2 GARMIN interfaced with GI 106A		9.700	25.20
A	23-005B	COM2/NAV2 KX 155A VOR/LOC HONEYWELL (KI 203 indicator)		6.945	22.44
A	23-005C	COM2/NAV2 KX 155A VOR/ILS HONEYWELL (KI 204 indicator)		7.474	22.44
A	K805 11M	VHF/COM 2 KY 196 A 30 HONEYWELL		5.071	28.74

SECTION 6
WEIGHT AND BALANCE

SOCATA
MODEL TB 10

S/ R/ A/ O	ITEM OPT10	REQUIRED (R) OR STANDARD (S) OR OPTIONAL (A or O) EQUIPMENT	*	WEIGHT per unit lb (kg)	ARM in. (m)
A	054930 M	VHF 2 faired antenna DMC 70 1/AX DORNE & MARGOLIN 23-60 - Static dischargers		1.246	46.18
A	J884 00M	ESD protection		/	/

S/ R/ A/ O	ITEM OPT10	REQUIRED (R) OR STANDARD (S) OR OPTIONAL (A or O) EQUIPMENT	*	WEIGHT per unit lb (kg)	ARM in. (m)
		24 - ELECTRICAL POWER			
		24-30 - DC generation			
R		Alternator 70A ALU 8421 or ALU 8521 PRESTOLITE/ELECTROSYSTEMS or LW 14324 LYCOMING		12.985	- 37.80
R		Battery G242-10AH GILL		26.962	- 2.76
R		Battery relay 70 117 221.5 ESSEX		0.772	- 1.18
R		Voltage regulator TB20 61215 P/N BOO 368.5 LAMAR		0.375	3.94
R		Pedestal electrical equipment TB10 61216		0.728	29.53
A	C839 00M	Converter 28 V - 14 V LT- 71A KGS		1.653	39.37
A	D907 00M	Voltmeter - ammeter indicator ELECTRONICS INTERNATIONAL		0.805	26.77
		24-40 - External power supply			
S		Ground power receptacle TB10 61830		3.682	49.61
A	C841 00M	Ground power extension		4.740	91.73
		24-50 - Distribution			
R		Standard circuit breakers panel TB10 61212		1.962	29.92
R		Printed circuits assembly on firewall TB20 61210 including fuses printed circuit, lights warning printed circuit, pitot and alternator output printed circuit		0.948	0.39

S/ R/ A/ O	ITEM OPT10	REQUIRED (R) OR STANDARD (S) OR OPTIONAL (A or O) EQUIPMENT	*	WEIGHT per unit lb (kg)	ARM in. (m)
		25 - EQUIPMENT AND FURNISHINGS			
		25-10 - Cockpit			
O	25-003A	Leather seats assembly with head-rests : - Front seats (Qty 2) PMV - Rear seat PMV		55.115 19.621	50.20 84.65
		25-11 - Front seats			
R		Front seats with head-rests TB10 74203		52.029	50.20
		25-12 - Rear bench			
R		Rear seats with head-rests TB10 74204		18.298	84.62
		25-13 - Safety and harnesses belts			
R		Front seat belt TB10 79013 P/N 10.4022.000.002 ANJOU AERO		2.646	47.24
S		Rear reel safety belt TB10 79000		2.646	106.30
A	064000 M	3rd rear reel safety belt		1.918	106.30
		25-14 - Central pedestal			
S		Lighter R.V.I : - Plug 5000 361 037 R.V.I - Fixed part 5000 361 635 R.V.I - Light 5000 462 170 R.V.I		0.154	37.80
S		Front ash-tray		0.882	43.31
S		Rear ash-tray		0.353	65.35
		25-15 - Upper duct			
S		Sun visor PLEXIGLAS		0.683	41.34
		25-17 - Instrument panel			
S		R.H. large instrument panel		4.740	23.62

S/ R/ A/ O	ITEM OPT10	REQUIRED (R) OR STANDARD (S) OR OPTIONAL (A or O) EQUIPMENT	*	WEIGHT per unit lb (kg)	ARM in. (m)
25-60 - Emergency equipment					
A	F902 00M	Axe		2.535	37.40
A	F903 00M	Life jackets (Qty 4)		8.818	124.80
A	H881 00M	First aid case		4.409	90.95
25-61 - Emergency locator transmitter					
A	25-001A	Emergency locator transmitter ELT 91 SOCATA P/N ELT 91A 2560 000 000 (TSO)		3.351	103.15
A	J908 00M	Three-frequency emergency locator transmitter ELT 96 SOCATA (EUROCAE)		3.638	106.30
A	J924 00M	Emergency locator transmitter ELT 90 SOCATA (EUROCAE)		3.351	103.15
A	J931 00M	Emergency locator transmitter ELT 200 ARTEX (For export only)		2.866	103.15
A	J931 50M	Provisions assy for ELT 200 ARTEX (For export only)		0.220	103.15
A	J933 00M	Three-frequency emergency locator transmitter ELT 97 SOCATA (TSO)		3.638	106.30
A	051730 M	Emergency locator transmitter JE2 NG JOLLIET (forward baggage compartment)		3.086	109.45

SECTION 6
WEIGHT AND BALANCE

SOCATA
MODEL TB 10

S/ R/ A/ O	ITEM OPT10	REQUIRED (R) OR STANDARD (S) OR OPTIONAL (A or O) EQUIPMENT	*	WEIGHT per unit lb (kg)	ARM in. (m)
26 - FIRE PROTECTION					
A	F823 00M	Cabin halon extinguisher FH 15N AREOFEU		4.409	37.80
A	F823 10M	Cabin halon extinguisher H1-10 AIR MAIP		4.850	37.80
A	F823 20M	Cabin halon extinguisher H1-10 AIR MAIP (with special support)		5.313	37.80
A	F823 30M	Cabin halon extinguisher L'HOTELLIER		3.638	37.68
A	F883 00M	Cabin powder extinguisher AFT 15N AREOFEU		4.608	37.80

S/ R/ A/ O	ITEM OPT10	REQUIRED (R) OR STANDARD (S) OR OPTIONAL (A or O) EQUIPMENT	*	WEIGHT per unit lb (kg)	ARM in. (m)
		27 - FLIGHT CONTROLS			
		27-20 - Yaw control			
A	059700 M	Yaw, roll controls interconnection		2.138	16.14
		27-50 - Wing flaps (control)			
R		Flaps actuator TB10 61206 P/N 700-239 LPMI		4.365	61.81
R		Flaps control selector TB10 61227		0.331	31.50
R		Flaps position indicator TB20 61232		0.132	31.50
R		Flaps relay + support TB10 61236 : - 2 relays HG2-24 VDC MATSUSHITA - 2 supports HG2 SS MATSUSHITA		0.551 0.110	78.35 78.35
O	C569 10M	Flaps preselection (with new switch)		0.220	39.37

SECTION 6
WEIGHT AND BALANCE

SOCATA
MODEL TB 10

S/ R/ A/ O	ITEM OPT10	REQUIRED (R) OR STANDARD (S) OR OPTIONAL (A or O) EQUIPMENT	*	WEIGHT per unit lb (kg)	ARM in. (m)
		28 - FUEL SYSTEM			
		28-10 - Fuel tanks			
A	058040 M	Ferry fuel tank (TB20 52925)		63.933	78.35
		28-20 - Fuel supply			
R		Fuel electric pump TB10 61218000 P/N 476284 FACET/BENDIX or P/N 476284E FACET (PUROLATOR)		1.653 1.587	- 0.79 - 0.79
R		Fuel selector/filter TB20 52026		1.301	44.49
		28-40 - Fuel indication			
S		Fuel low level warning		0.728	33.46

S/ R/ A/ O	ITEM OPT10	REQUIRED (R) OR STANDARD (S) OR OPTIONAL (A or O) EQUIPMENT	* WEIGHT per unit lb (kg)	ARM in. (m)
		31 - INDICATING/RECORDING SYSTEMS		
		31-10 - Control and indicating panels		
R		Engine and fuel controls PEINTATEC or MORITZ TB10 76201	1.102 2.998	24.80 24.80
O	F634 00M	Raised radio console	3.131	23.62
O	F634 10M	Raised radio console	1.014	23.62
		31-20 - Independent instruments		
A	D571 00M	Hourmeter DATCON	0.551	23.62
A	D638 00M	Digital chronometer (L.H. station) ASTROTECH	0.507	35.43
A	D638 10M	Digital chronometer (R.H. station) ASTROTECH	0.507	35.43
A	D638 20M	Digital chronometer (R.H. station) ASTROTECH	0.507	35.43
A	D680 00M	Quartz chronometer THOMMEN (60 minutes elapsed time indicator) P/N Q18.945.22.28.1KB or Q18.945.22.28.1ME	0.485	35.43
A	D680 10M	Quartz chronometer THOMMEN (60 minutes elapsed time indicator) P/N Q18.945.22.28.1KB or Q18.945.22.28.1ME (R.H. station)	0.485	35.43
A	D680 20M	Quartz chronometer THOMMEN (60 minutes elapsed time indicator) P/N Q18.945.22.28.1KB or Q18.945.22.28.1ME	0.485	35.43
A	D680 30M	Quartz chronometer THOMMEN (12 minutes elapsed time indicator) P/N Q18.948.22.28.1ME	0.485	35.43
A	D806 00M	Three-axis accelerometer	0.992	23.62

SECTION 6
WEIGHT AND BALANCE

SOCATA
MODEL TB 10

S/ R/ A/ O	ITEM OPT10	REQUIRED (R) OR STANDARD (S) OR OPTIONAL (A or O) EQUIPMENT	*	WEIGHT per unit lb (kg)	ARM in. (m)
A	D829 00M	Mechanical chronometer THOMMEN P/N B18.945.22.28.1K		0.485	35.43
A	D829 10M	Mechanical chronometer THOMMEN P/N B18.945.22.28.1K (R.H. station)		0.485	35.43
A	D833 00M	Digital clock/chronometer LC2 ASTROTECH		0.331	23.62
O	D911 00M	Hourmeter "Flight duration" DATCON NOTE : Tachometer-Hourmeter, refer to ATA 77		0.661	31.50
		31-50 - Central warning systems			
R		Advisory panel TB20 61285		0.529	23.62
A	C561 00M	Starter warning light		0.132	39.37

S/ R/ A/ O	ITEM OPT10	REQUIRED (R) OR STANDARD (S) OR OPTIONAL (A or O) EQUIPMENT	*	WEIGHT per unit lb (kg)	ARM in. (m)
		32 - LANDING GEARS			
		32-10 - Main landing gear			
S		L.H. fairing TB10 48012006		11.905	62.20
S		R.H. fairing TB10 48012007		11.905	62.20
		32-20 - Nose landing gear			
S		Front fairing TB10 48014004 Rear fairing TB10 48014005		6.173	- 10.24
O	052500 M	Airplane without LDG fairings		- 29.983	47.24
		32-40 - Wheels and brakes			
R		Main LDG wheel assy (2) 40-97E Type III CLEVELAND		5.842	59.84
R		Main LDG wheel assy (2) 40-97F CLEVELAND		6.482	59.84
R		Main LDG brake assy (2) 91.50 CLEVELAND		1.918	59.84
R		Main LDG tire (2) 6.00-6 6 PLYS GOODYEAR (Pre-MOD.118 or MOD.120)		8.818	59.84
R		Main LDG tire (2) 6.00-6 6 PR TT DUNLOP (Pre-MOD.118 or MOD.120)		8.818	59.84
R		Main LDG tire (2) 6.00-6 6 PR P/N 606C61.6 GOODYEAR (Post-MOD.118 or MOD.120)		8.818	59.84
R		Main LDG tire (2) 6.00-6 6 120TT MICHELIN (Post-MOD.118 or MOD.120)		8.818	59.84
R		Main LDG tube (2) 6.00-6 DUNLOP (Pre-MOD.118 or MOD.120)		1.653	59.84
R		Main LDG tube (2) P/N 092-315-0 MICHELIN (Post-MOD.118 or MOD.120)		2.425	59.84
R		Main LDG tube (2) 15.6.00-6 TR GOODYEAR (Post-MOD.118 or MOD.120)		1.653	59.84
R		Nose LDG wheel assy 40-77 B CLEVELAND		2.822	- 16.93

SECTION 6
WEIGHT AND BALANCE

SOCATA
MODEL TB 10

S/ R/ A/ O	ITEM OPT10	REQUIRED (R) OR STANDARD (S) OR OPTIONAL (A or O) EQUIPMENT	*	WEIGHT per unit lb (kg)	ARM in. (m)
R		Nose LDG tire 5.00-5 6 PRTT DUNLOP		6.393 or 5.798	- 16.93
R		Nose LDG tire 5.00-5 6 120TT MICHELIN		6.393	- 16.93
R		Nose LDG tire 5.00-5 6 120TT AVIATOR		5.489	- 16.93
R		Nose LDG tire 5.00-5 6 PR P/N 505C61.8 GOODYEAR		5.291	- 16.93
R		Nose LDG tube 5.00-5 DUNLOP		1.455	- 16.93
R		Nose LDG tube TR67A P/N 092-308-0 MICHELIN		1.455	- 16.93
R		Nose LDG tube 5.00-5 TR67 GOODYEAR		1.455	- 16.93
S		Braking control (R.H. post) TB10 45030		3.307	11.81
		32-60 - Position indicating system and alarms			
A	B877 00M	LDG simulator assy		0.595	23.62

S/ R/ A/ O	ITEM OPT10	REQUIRED (R) OR STANDARD (S) OR OPTIONAL (A or O) EQUIPMENT	*	WEIGHT per unit lb (kg)	ARM in. (m)
		33 - LIGHTS			
		33-10 - Cockpit			
S		Rear cabin lighting TB20 64202		0.220	65.35
S		Instrument panel lighting TB20 64201		0.485	23.62
S		Front cabin lighting (emerg.) TB20 64202		0.507	44.09
S		Maps reading light		0.176	25.59
A	E873 00M	Emergency lighting system		4.079	104.72
		33-40 - External lighting			
S		Landing light G.E. 4591		0.353	35.43
S		Taxi light G.E. 4626		0.353	35.43
S		Navigation and anticollision lights assy WHELEN TB20 63212		4.431	64.96
A	33-001A	Recognition lights WHELEN		0.463	33.46
A	E537 00M	Strobe light JPC on vertical stabilizer		1.874	145.67
A	E537 10M	Strobe lights JPC on vertical stabilizer and under fuselage		3.197	140.55
A	E537 20M	Strobe light JPC on vertical stabilizer (red glass)		1.874	145.67
O	E826	Strobe light WHELEN (tail)		2.094	145.67
O	E848 00M	Light control box JX 128 FLASHELEK		0.551	55.31

SECTION 6
WEIGHT AND BALANCE

SOCATA
MODEL TB 10

S/ R/ A/ O	ITEM OPT10	REQUIRED (R) OR STANDARD (S) OR OPTIONAL (A or O) EQUIPMENT	*	WEIGHT per unit lb (kg)	ARM in. (m)
		34 - NAVIGATION			
		34-10 - Flight environment data			
		34-11 - Air data systems			
R		Altimeter TB20 76222 P/N 5934 PD3 Code A253 UNITED INSTRUMENTS		0.816	25.59
R		True airspeed indicator with integrated lighting TB20 76223 P/N 8125 Code B605 UNITED INSTRUMENTS		0.728	24.80
S		Vertical speed indicator TB20 76224 P/N 7000 Code C83 UNITED INSTRUMENTS		1.014	23.62
S		Air data systems TB10 77200 : - Heated pitot - Alternate static source (in cabin)		1.190 0.331	53.15 23.62
A	C635 00M	2nd heated pitot (R.H. wing)		1.190	47.24
A	D681 00M	2nd altimeter 20000 ft		1.433	19.69
A	D803 10M	Installation of 2nd airspeed indicator		1.213	23.62
A	D811 00M	Alti-coder KE 127 KING		1.433	17.72
A	D830 00M	Alti-coder 20000 ft TRANSCALL		1.433	17.72
A	D831 00M	Alti-coder 30000 ft TRANSCALL		1.433	17.72
A	D832 00M	2nd altimeter 35000 ft		1.433	19.69
A	D897 00M	2nd vertical speed indicator (R.H. station) P/N 7000 C83 UNITED INSTRUMENTS		1.521	23.62
A	D915 00M	Metric altimeter # 3 P/N 5940 UNITED INSTRUMENTS		0.926	23.62
O	K608 20M	Alti-coder KEA 130A (35000 ft) KING		1.764	21.65
O	K608 30M	Alti-coder 20000 ft UNITED INSTRUMENTS		1.764	21.65

S/ R/ A/ O	ITEM OPT10	REQUIRED (R) OR STANDARD (S) OR OPTIONAL (A or O) EQUIPMENT	*	WEIGHT per unit lb (kg)	ARM in. (m)
A	N846 00M	Altitude encoder AR850 NARCO		1.323	19.69
		34-13 - Outside temperature			
S		Outside air temperature indicator (water-tight connector on sensor) TB10 76202		0.551	23.62
A	D804 20M	Outside air temperature indicator (water-tight connector on sensor) (OPT10 D804 10M retrofit)		0.551	23.62
A	D910 20M	Outside air temperature indicator (water-tight connector on sensor) DAVTRON		0.551	23.62
		34-20 - Attitude and direction			
		34-21 - Heading reference system			
A	34-302A	HSI assy KCS 55A HONEYWELL		12.721	67.32
A	D914 00M	Heading gyro indicator SIGMA-TEK (on L.H. instrument panel)		2.668	23.62
A	D914 10M	Heading gyro indicator SIGMA-TEK (on R.H. instrument panel)		2.976	19.69
A	D922 00M	Electric heading gyro indicator 205-1BL		3.219	23.62
A	K660 20M	HSI assy KING with heading recopy capability (30/400 Hz) with vertical KA 51B		12.720	67.32
A	K660 30M	HSI assy KING with heading recopy capability (30/400 Hz) with horizontal KA 51B		12.720	67.32
A	K660 50M	HSI assy KING with horizontal KA 51B (if GPS KLN 90B installed)		12.720	67.32
A	K660 60M	HSI assy KING with vertical KA 51B (if GPS KLN 90B installed)		12.720	67.32
A	067140 M	Heading indicator KG 107		2.690	20.47

SECTION 6
WEIGHT AND BALANCE

SOCATA
MODEL TB 10

S/ R/ A/ O	ITEM OPT10	REQUIRED (R) OR STANDARD (S) OR OPTIONAL (A or O) EQUIPMENT	*	WEIGHT per unit lb (kg)	ARM in. (m)
		34-22 - Turn and bank indication			
R		Turn-and-bank indicator TB20 76825 UNITED INSTRUMENTS		1.675	23.62
O	34-002A	Electrical turn coordinator UNITED INSTRUMENTS		1.323	23.62
O	D697 00M	Electrical turn coordinator CASTLEBERRY		1.698	23.62
A	D818 10M	Slip indicator (R.H. station) UNITED INSTRUMENTS		1.675	23.62
		34-23 - Magnetic compass			
R		Compass TB20 76229 P/N C2400 L 4P (28 V) AIRPATH		0.595	20.47
		34-24 - ADI and standby horizon			
A	34-001A	Electrical attitude gyro indicator 1100-28L(5F) BFG (Not valid for U.K. aircraft)		2.866	24.41
A	34-001C	Electrical attitude gyro indicator 1100-28LS(5F) BFG (on L.H. instrument panel) (Not valid for U.K. aircraft)		2.866	24.41
A	34-001D	Electrical attitude gyro indicator 1100-28LS(5F) BFG (on L.H. instrument panel) (Not valid for U.K. aircraft)		2.866	24.41
A	067230 M	Attitude gyro indicator KG 258 for KAP 150 (Not valid for U.K. aircraft)		3.086	20.47
A	067330 M	Attitude gyro indicator with Flight Director KI 256 for KFC 150		3.285	20.47
		34-25 - Radio magnetic indication			
A	K584 00M	RMI KI 22900 (without switching) KING		3.086	21.65
A	K584 10M	RMI KI 22900 (with switching) KING		3.307	21.65
A	K819 00M	RMI KNI 582 KING		3.417	21.65

S/ R/ A/ O	ITEM OPT10	REQUIRED (R) OR STANDARD (S) OR OPTIONAL (A or O) EQUIPMENT	*	WEIGHT per unit lb (kg)	ARM in. (m)
		34-30 - Landing and taxiing aids			
		34-31 - Marker			
A	K676 00M	Marker receiver indicator KR 21 KING		1.257	21.65
		34-40 - Independent position determining			
		34-41 - Stormscope			
A	34-502A	Stormscope WX 500 BFG		4.960	117.32
A	J820 00M	Stormscope WX 1000 BFG (on panel strip)		15.432	83.07
A	J820 10M	Stormscope WX 1000 BFG (on R.H. instrument panel)		15.432	83.07
A	J828 10M	Stormscope WX 1000 + BFG		15.432	83.07
A	J918 00M	Stormscope WX-900 BFG		4.806	85.43
		34-50 - Dependent position determining			
		34-51 - NAV 1 installation			
A	K663 51M	VHF assy COM1/NAV1 (VOR/LOC) KX 155 KING		7.100	23.23
A	K663 61M	VHF assy COM1/NAV1 (VOR/ILS) KX 155 KING		6.173	23.23
A	K663 71M	VHF assy COM1/NAV1 (VOR/LOC) KX 155 with audio amplifier KING		7.870	24.80
A	K812 51M	VHF assy COM1/NAV1 (VOR/LOC) KX 165 KING		7.165	23.23
A	K812 61M	VHF assy COM1/NAV1 (VOR/ILS) KX 165 KING		5.644	23.23
A	K813 00M	VOR/ILS indicator KI 206-04 KING		1.631	21.65
A	K813 10M	VOR/ILS indicator KI 206-05 KING		1.764	21.65
A	K814 00M	VOR/ILS indicator KI 204 KING		1.918	21.65

SECTION 6
WEIGHT AND BALANCE

SOCATA
MODEL TB 10

S/ R/ A/ O	ITEM OPT10	REQUIRED (R) OR STANDARD (S) OR OPTIONAL (A or O) EQUIPMENT	*	WEIGHT per unit lb (kg)	ARM in. (m)
A	K847 00M	Converter VOR/LOC KN 72 KING 34-52 - NAV 2 installation		1.653	43.31
A	K663 21M	VHF assy COM2/NAV2 (VOR/LOC) KX 155 KING		7.275	20.08
A	K663 31M	VHF assy COM2/NAV2 (VOR/ILS) KX 155 KING		6.415	23.23
A	K812 11M	VHF assy COM2/NAV2 (VOR/ILS) KX 165 KING		5.997	22.83
A	K812 31M	VHF assy COM2/NAV2 (VOR/LOC) KX 165 KING		7.341	23.23
A	K813 00M	VOR/ILS indicator KI 206-04 KING		1.631	21.65
A	K813 10M	VOR/ILS indicator KI 206-05 KING		1.764	21.65
A	K814 00M	VOR/ILS indicator KI 204 KING 34-53 - Transponder		1.918	21.65
A	34-501A	Transponder GTX 320 GARMIN		3.086	29.53
A	34-504A	Transponder GTX 327 GARMIN		3.968	21.65
A	K656 00M	ATC KT 76 A KING on radio console		3.682	20.08
A	K656 20M	ATC KT 76 A KING on R.H. panel strip (with support)		3.836	21.65
A	K876 00M	Transponder ATC KT 71 KING		4.630	22.44
A	K876 10M	Transponder ATC KT 71 KING (on R.H. panel strip)		4.630	22.44
A	K929 00M	Transponder ATC KT 76C KING (on R.H. panel strip) 34-54 - Automatic Direction Finder (ADF)		3.527	23.62
A	34-300A	ADF assy KR 87 SC+ (Indicator KI 227.01) HONEYWELL		8.885	90.16

S/ R/ A/ O	ITEM OPT10	REQUIRED (R) OR STANDARD (S) OR OPTIONAL (A or O) EQUIPMENT	*	WEIGHT per unit lb (kg)	ARM in. (m)
A	34-300B	ADF assy KR 87 SC+ (Indicator KI 227.00) HONEYWELL		8.885	90.16
A	34-300C	ADF assy KR 87 SC+ (Indicator KI 229) HONEYWELL		11.045	76.77
A	34-300D	ADF assy KR 87 SC+ (Indicator KNI 582) HONEYWELL		11.177	76.77
A	K655 00M	ADF KR 87.01/04 (Indicator KI 227.00) KING (on radio console)		8.730	90.16
A	K655 10M	ADF KR 87.01/04 (Indicator KI 227.01) KING (on radio console)		8.730	90.16
A	K655 20M	ADF KR 87 KING		8.025	96.06
A	K655 40M	ADF KR 87 (Indicator KI 227.01) KING (on R.H. panel strip)		8.730	90.16
A	K917 00M	ADF2 KR 87 KING		9.436	94.49
		34-55 - DME installation			
A	34-305A	DME KN 62A SC+ HONEYWELL		3.527	30.71
A	K657 00M	DME KN 62A KING		3.682	21.26
A	K657 10M	DME KN 64 KING		3.682	21.26
A	K664 00M	DME KN 63 KING		5.489	40.94
		34-57 - Global Positioning System (GPS)			
A	34-301A	GPS KLN 94 HONEYWELL interfaced with HSI		5.952	25.98
A	34-306A	GPS KLN 94 HONEYWELL "Stand alone"		4.850	28.74
A	34-500A	Color Skymap capability CM 2000 SKYFORCE		0.970	30.51
A	K920 10M	GPS KLN 89B KING "Stand alone"		4.519	25.20

SECTION 6
WEIGHT AND BALANCE

SOCATA
MODEL TB 10

S/ R/ A/ O	ITEM OPT10	REQUIRED (R) OR STANDARD (S) OR OPTIONAL (A or O) EQUIPMENT	*	WEIGHT per unit lb (kg)	ARM in. (m)
A	K926 10M	GPS KLN 89B KING interfaced with HSI KI 525A (KCS 55A compass system)		5.578	22.83
A	K927 10M	GPS KLN 90B KING interfaced with HSI and A/P, without RMI (KA92 antenna) 34-60 - Flight management computing 34-62 - Multifunction display		9.943	21.26
A	34-304A	MFD KMD 550 HONEYWELL		6.614	21.65

S/ R/ A/ O	ITEM OPT10	REQUIRED (R) OR STANDARD (S) OR OPTIONAL (A or O) EQUIPMENT	*	WEIGHT per unit lb (kg)	ARM in. (m)
		37 - VACUUM			
		37-11 - Distribution (normal)			
S		Vacuum pump SIGMA-TEK (with filter) or Vacuum pump CHAMPION or AERO ACCESSORIES (with AIRBORNE filter) TB20 78817		5.225	- 15.75
A	A904 10M	Vacuum pump SIGMA-TEK (with filter) (when stormscope installed, refer to ATA 34)		5.225	- 15.75
		37-12 - Distribution (emergency)			
A	C632 00M	Auxiliary dry air pump		12.456	30.31
		37-20 - Indicating			
S		Vacuum system warning light TB20 78817		0.198	0.39

SECTION 6
WEIGHT AND BALANCE

SOCATA
MODEL TB 10

S/ R/ A/ O	ITEM OPT10	REQUIRED (R) OR STANDARD (S) OR OPTIONAL (A or O) EQUIPMENT	*	WEIGHT per unit lb (kg)	ARM in. (m)
A	B896 00M	<p>53 - FUSELAGE</p> <p>Tail cone protection</p>		0.661	215.67

S/ R/ A/ O	ITEM OPT10	REQUIRED (R) OR STANDARD (S) OR OPTIONAL (A or O) EQUIPMENT	*	WEIGHT per unit lb (kg)	ARM in. (m)
		56 - WINDOWS			
S		Colourless windows assy TB10 24000 : - Windshield - Door window - Rear side window		11.640 4.056 2.535	27.56 55.12 86.61
A	F868 00M	Ventilation scoops		0.220	79.53

SECTION 6
WEIGHT AND BALANCE

SOCATA
MODEL TB 10

S/ R/ A/ O	ITEM OPT10	REQUIRED (R) OR STANDARD (S) OR OPTIONAL (A or O) EQUIPMENT	*	WEIGHT per unit lb (kg)	ARM in. (m)
R		61 - PROPELLER Propeller HC-C2YK-1BF/F 7666 A-2 HARTZELL		54.233	- 47.64
R		61-20 - Controls Propeller governor F4 HARTZELL		5.731	- 14.96

S/ R/ A/ O	ITEM OPT10	REQUIRED (R) OR STANDARD (S) OR OPTIONAL (A or O) EQUIPMENT	*	WEIGHT per unit lb (kg)	ARM in. (m)
R		72 - PISTON ENGINE Engine O-360-A1AD LYCOMING		287.70	- 27.95

SECTION 6
WEIGHT AND BALANCE

SOCATA
MODEL TB 10

S/ R/ A/ O	ITEM OPT10	REQUIRED (R) OR STANDARD (S) OR OPTIONAL (A or O) EQUIPMENT	*	WEIGHT per unit lb (kg)	ARM in. (m)
R		74 - IGNITION 74-10 - Electric generation system Dual magneto D4LN 3000 BENDIX		10.582	- 17.32

S/ R/ A/ O	ITEM OPT10	REQUIRED (R) OR STANDARD (S) OR OPTIONAL (A or O) EQUIPMENT	*	WEIGHT per unit lb (kg)	ARM in. (m)
		77 - ENGINE INDICATING			
		77-10 - Power			
R		Manifold pressure TB10 76224 P/N 6111 Code D73 UNITED INSTRUMENTS		0.948	25.59
R		Tachometer-Hourmeter NRF 80 P/N LM 03 or LM 031 or LM 033 LMI		0.860	23.62
		77-20 - Temperature			
S		EGT/CHT TB20 76802 ALCOR		1.323	19.69
A	D684 10M	Carburetor temperature (without cover on R.H. instrument panel)		0.331	23.62

SECTION 6
WEIGHT AND BALANCE

SOCATA
MODEL TB 10

S/ R/ A/ O	ITEM OPT10	REQUIRED (R) OR STANDARD (S) OR OPTIONAL (A or O) EQUIPMENT	*	WEIGHT per unit lb (kg)	ARM in. (m)
		79 - LUBRICATION			
		79-10 - Storage			
A	065810 M	Oil drain door		0.220	- 25.59
		79-20 - Distribution			
R		Oil cooler 20002A NDM		1.742	- 20.47

S/ R/ A/ O	ITEM OPT10	REQUIRED (R) OR STANDARD (S) OR OPTIONAL (A or O) EQUIPMENT	*	WEIGHT per unit lb (kg)	ARM in. (m)
		80 - STARTING			
R		Starter : - PRESTOLITE/ELECTROSYSTEMS MHB 4016 or MHB 6016 or - LYCOMING LW 15572 or 31B22474		17.990 8.091	- 39.37 - 37.40
R		Starter relay CE 1971 060 F PARIS RHONE		1.499	87.40

INTENTIONALLY LEFT BLANK

SECTION 7

DESCRIPTION

TABLE OF CONTENTS

	Page
GENERAL	7.5
AIRFRAME	7.5
■ WINGS	7.5
EMPELLAGE	7.6
FLIGHT CONTROLS	7.7
SURFACES	7.7
TRIM SYSTEMS	7.7
INSTRUMENT PANEL	7.9
ADVISORY PANEL	7.14
SWITCH-BREAKERS PANEL	7.14
CIRCUIT BREAKERS PANEL	7.14
GROUND CONTROL	7.17
WING FLAPS	7.19
LANDING GEAR	7.19
BAGGAGE COMPARTMENT	7.20
CARGO CONFIGURATION	7.20
SEATS, SEAT BELTS AND SHOULDER HARNESSSES	7.21
FRONT SEATS	7.21
■ REAR BENCH OR, <u>Post-MOD.151</u> , REAR SEATS	7.21
HEAD-RESTS	7.21
SEAT BELTS	7.24

TABLE OF CONTENTS
(Continued)

	Page
DOORS AND EXITS	7.26
DOORS	7.26
EXITS	7.26
CONTROLS LOCK	7.26
ENGINE	7.27
ENGINE CONTROLS	7.28
ENGINE INSTRUMENTS	7.29
IGNITION - STARTER SYSTEM	7.29
NEW ENGINE BREAK-IN AND OPERATION	7.30
ENGINE LUBRICATION SYSTEM	7.30
AIR INDUCTION SYSTEM	7.30
EXHAUST SYSTEM	7.31
PROPELLER	7.31
FUEL SYSTEM	7.31
BRAKE SYSTEM	7.36
BRAKING	7.36
PARKING BRAKE	7.36
STANDARD ELECTRICAL SYSTEM	7.37
ALTERNATOR CONTROL UNIT	7.37
MAIN SWITCH	7.37
ALTERNATOR CONTROL	7.37
AVIONICS POWER SWITCH	7.39
VOLTMETER	7.40
AMMETER	7.40
VOLTMETER AND AMMETER (<u>Post-MOD.182</u>)	7.40A
CIRCUIT BREAKERS AND FUSES	7.41
"ALT" WARNING LIGHT (LOW VOLTAGE)	7.42
GROUND POWER RECEPTACLE	7.42

TABLE OF CONTENTS
(Continued)

	Page
IFR AND NIGHT VFR ELECTRICAL SYSTEMS	7.42
LIGHTING SYSTEMS	7.42
EXTERIOR LIGHTING	7.42
INTERIOR LIGHTING	7.43
DEMISTING, AIR REGULATION, VENTILATION, FIRE CUT-OFF	7.45
DEMISTING	7.45
AIR REGULATION	7.45
VENTILATION	7.47
FIRE CUT-OFF	7.47
AIRSPEED INDICATING SYSTEM AND INSTRUMENTS	7.48
TRUE AIRSPEED INDICATOR	7.48
VERTICAL SPEED INDICATOR	7.51
ALTIMETER	7.51
ALTERNATE STATIC SOURCE	7.51
VACUUM SYSTEM AND INSTRUMENTS	7.52
ATTITUDE GYRO INDICATOR	7.52
HEADING INDICATOR	7.53
VACUUM GAGE	7.53
AUXILIARY DRY AIR PUMP	7.53
AUTOPILOTS	7.54
STALL WARNING SYSTEM	7.54
STATIC DISCHARGERS	7.54
RADIO EQUIPMENT	7.55
TURN AND BANK INDICATOR	7.55
CLEAR-VISION WINDOW	7.55

TABLE OF CONTENTS
(Continued)

	Page
SUN VISOR	7.55
FIRE EXTINGUISHER	7.55
■ EMERGENCY LOCATOR TRANSMITTER	7.56

GENERAL

This section provides description and operation of the SOCATA Model TB 10 airplane and its systems. Some of the equipment described herein is optional and may not be installed in the airplane.

Details of other optional systems and equipment are presented in Section 9 "Supplements" of this Manual and any airplane/country specifics are given in Section "Specifics" hereto.

AIRFRAME

The TB 10 is an all-metal, four/five-place, cantilever low wing, single-engine airplane equipped with fixed tricycle landing gear and is designed to be used in normal and utility categories.

The fuselage consists of an all-metal aluminium alloy structure of semimonocoque design. It includes 10 frames. The main frames are as follows :

- Frame No. 0 on which firewall, engine mount and nose gear mount are fixed.
- Frame No. 1 on which wing front attachments are fixed.
- Frame No. 2 double frame which allows crossing and attachment of the wing spar.
- Frame No. 3 on which wing rear attachments are fixed.
- Frame No. 7 on which vertical stabilizer front attachment is fixed.
- Frame No. 8 on which vertical stabilizer rear attachment is fixed.
- Frame No. 9 on which horizontal stabilator hinge fittings are fixed.

The cabin section, from frame No. 0 to frame No. 6, is reinforced by horizontal spars made of extruded aluminium sections.

The streamlined fairing is ensured by a composite material upper duct which includes the two access "gull-wing" doors.

Access to the baggage compartment (behind the bench seat) is provided through a door located on the L.H. side of the fuselage.

WINGS

The wings contain integral fuel tanks. They consist of stamped metal ribs riveted to the wing skin and to monobloc spar.

Wings characteristics :

Profile	RA16-3C3
Aspect ratio	8
Dihedral	4°5
Aerodynamic chord	4.002 ft - 1.220 m
True chord	4.085 ft - 1.245 m
Wing area	128.091 sq.ft - 11.90 m ²
Wing setting	+ 3°
Ailerons :	
Unit area	4.897 sq.ft - 0.46 m ²
Mean span	4.081 ft - 1.244 m
Recoil and slotted type wing flaps :	
Unit area	10.010 sq.ft - 0.93 m ²
Mean span	8.366 ft - 2.550 m

EMPENNAGE

The vertical stabilizer consists of a fin and a rudder.

The horizontal stabilizer is of stabilator type with an automatic anti-tab controlled in its stabilator tab function.

Both are of conventional metal structure type (spar, ribs and skin).

Empennage characteristics :

Conventional type vertical stabilizer :

Fin area (fixed section)	
<u>Pre-MOD.151</u>	9.472 sq.ft - 0.88 m ²
Fin area (fixed section)	
<u>Post-MOD.151</u>	11.194 sq.ft - 1.04 m ²
Rudder area	6.781 sq.ft - 0.63 m ²

Stabilator type horizontal stabilizer :

Span	10.499 ft - 3.200 m
Stabilator area, anti-tab included	26.694 sq.ft - 2.48 m ²
Tab area	5.813 sq.ft - 0.54 m ²
Tab automaticity	85 %

FLIGHT CONTROLS

SURFACES

The airplane is equipped with a conventional three-axis surface system, consisting of aileron, stabilator and rudder surfaces.

Each front seat is provided with a control wheel which actuates ailerons and stabilator through rods and bellcranks. The control wheel being actuated fully, ailerons deflection (angles reference : wing chord) must be :

- upwards $15^{\circ} \pm 1.5^{\circ}$
- downwards $15^{\circ} \pm 1.5^{\circ}$

Stabilator deflection (angles reference : fuselage upper spar) must be :

- nose-up $- 17^{\circ} \pm 1^{\circ}$
- nose-down $+ 2^{\circ} \pm 1^{\circ}$

The stabilator consists of an automatic anti-tab, which automaticity is 85 %. This anti-tab can also be controlled through the pitch trim.

Each front seat is provided with a rudder pedal which controls the rudder through rods and bellcranks.

Rudder deflection (angles reference : fin chord) to the left and to the right is $25^{\circ} \pm 2^{\circ}$.

TRIM SYSTEMS

A manually-operated pitch trim is provided.

Stabilator trimming is accomplished by actuating on stabilator anti-tab through a control wheel vertically mounted on L.H. side of the control panel.

This control wheel actuates stabilator anti-tab through cables and an irreversibility system.

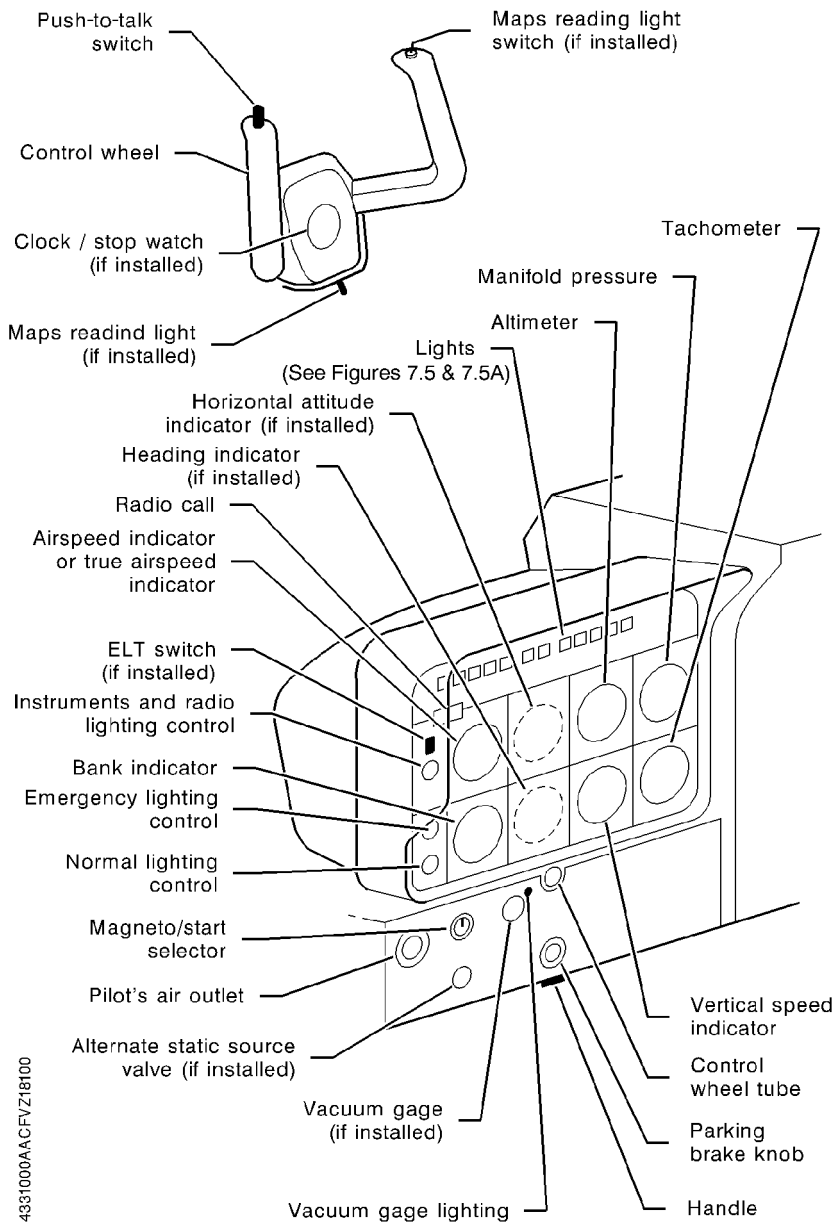

14331000AA CFVZ18100

Figure 7.1 - EXAMPLE OF INSTRUMENT PANEL AND L.H. SUBPANEL

A pointer indicator located on the right of the trim control wheel gives the anti-tab position. Forward rotation of the control wheel will trim nose-down, conversely, rearward rotation will trim nose-up.

Stabilator tab deflection (angles reference : stabilator profile chord) with stabilator in maximum nose-up attitude must be :

- nose-up - $2.5^{\circ} \pm 0.5^{\circ}$
- nose-down - $17^{\circ} \pm 1.5^{\circ}$

INSTRUMENT PANEL

L.H. instrument panel (see Figure 7.1) is designed around the basic "T" configuration.

The gyros (if installed) are located in front of the pilot and arranged vertically. The airspeed indicator or the true airspeed indicator and the altimeter are to the left and right of the gyros, respectively.

The upper edge of the instrument panel contains the advisory panel (see Figures 7.5 and 7.5A).

The left side of the panel contains lighting controls, emergency locator transmitter switch (if installed) and registration (enabling airplane radio call).

The L.H. panel strip (see Figure 7.1) contains from left to right : L.H. air outlet, magneto/start selector, parking brake knob ; alternate static source valve and vacuum gage (if installed) complete the L.H. panel strip.

The central console (see Figure 7.2) contains in the upper edge, the engine monitoring cluster, then radionavigation equipment vertically mounted to console lower edge.

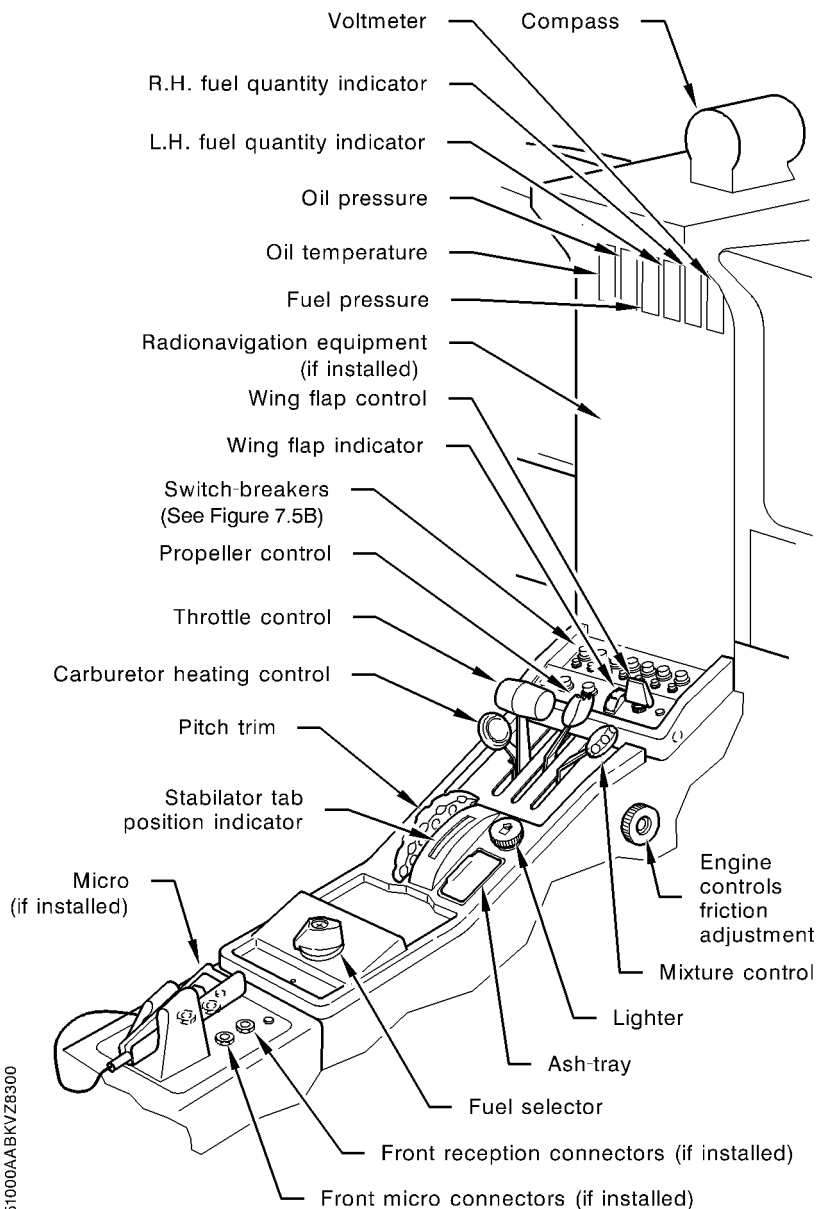

I4251000AABKVZ8300

Figure 7.2 - EXAMPLE OF CONSOLE AND PEDESTAL

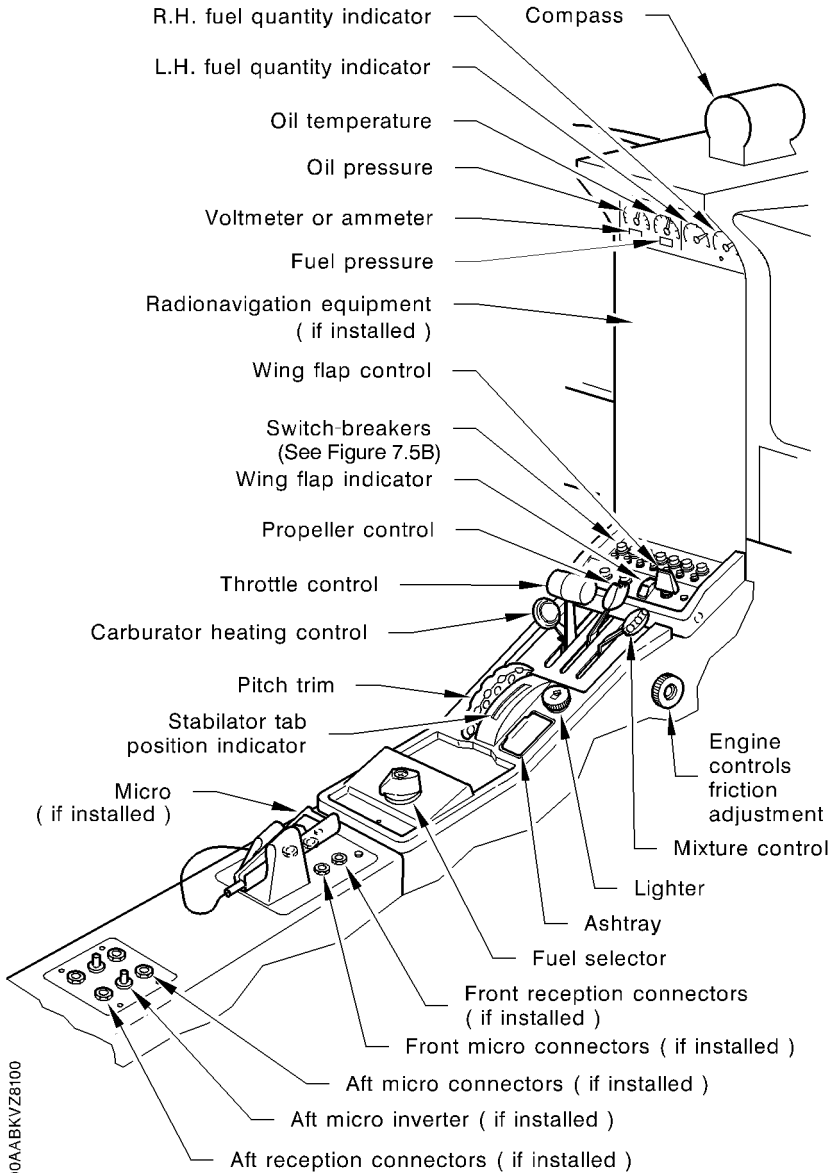

Figure 7.2A - EXAMPLE OF CONSOLE AND PEDESTAL

INTENTIONALLY LEFT BLANK

The central pedestal (see Figure 7.2) contains fore to aft :

- the switch-breakers panel, flap control and indicator
- the engine controls (from left to right : carburetor heating, throttle, propeller, mixture)
- the pitch trim and its indicator
- the lighter and the ash-tray
- the fuel selector
- the micro (if installed)
- the reception and micro jacks (if installed)
- on pedestal R.H. side, engine controls friction device.

Pre-MOD.151

The R.H. instrument panel (see Figure 7.3) contains the tachometer or tachometer-hourmeter and the manifold pressure indicator and spare locations for additional equipment [2nd altimeter, VOR/LOC indicator, outside air temperature, cylinder head temperature, exhaust gas temperature, ELT switch (according to ELT model)...].

Post-MOD.151

The R.H. instrument panel (see Figure 7.3A) contains the tachometer-hourmeter, the manifold pressure indicator, the outside air temperature indicator (OAT), the EGT/CHT indicator and spare locations for additional equipment [2nd altimeter, VOR/LOC indicator, ELT switch (according to ELT model)...].

The R.H. panel strip (see Figure 7.3) contains a location for radio equipment or any other one, cabin air selector, R.H. air outlet.

Upper duct central part (see Figure 7.4) contains fore to aft :

- "Flight conditions" placard,
- "Instruction" plate,
- Front overhead lights,
- Radio loud-speaker (if installed),
- Blower switch (if installed),
- Autopilot alarm (if installed),
- Rear overhead light,
- Rear air outlets,
- Stall warning (buzzer),
- Altitude selector alarm (if installed).

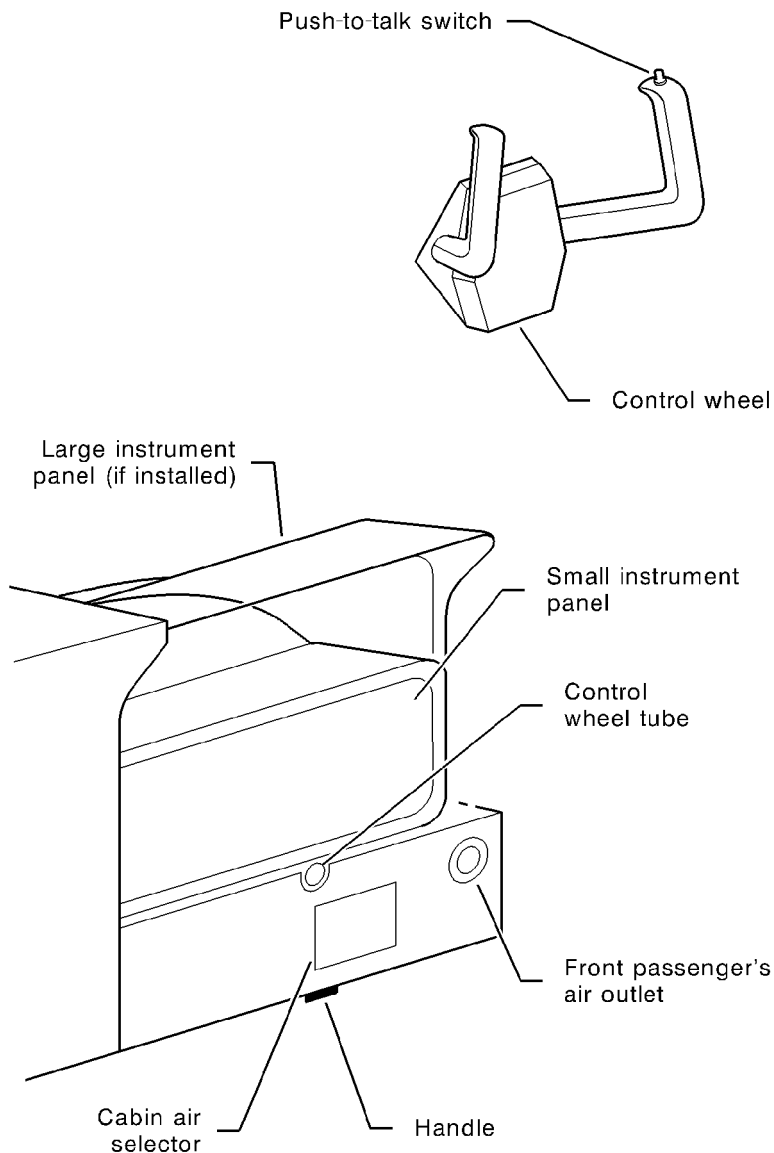

I4351000AACIVZ8100

Figure 7.3 - EXAMPLE OF INSTRUMENT PANEL AND R.H. SUBPANEL

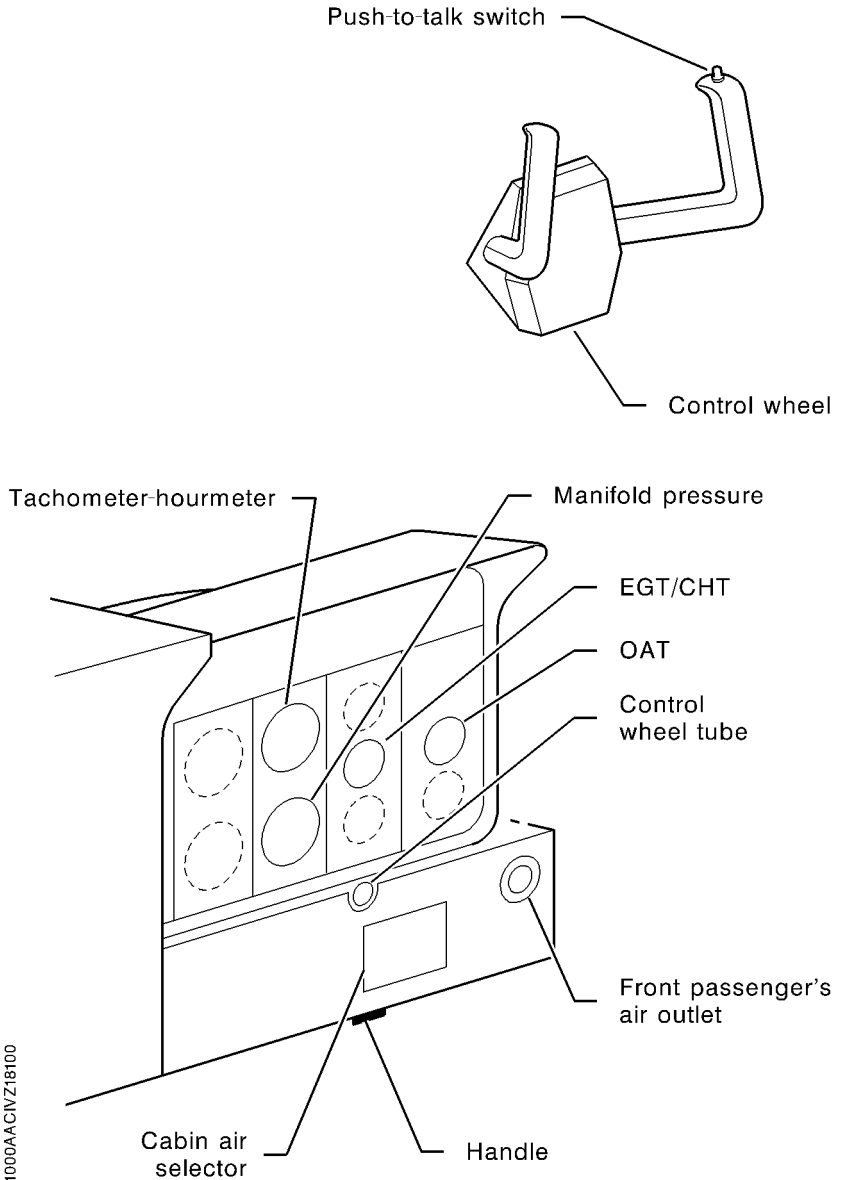

I4331000AA CIVZ18100

Figure 7.3A - EXAMPLE OF INSTRUMENT PANEL AND R.H. SUBPANEL

INTENTIONALLY LEFT BLANK

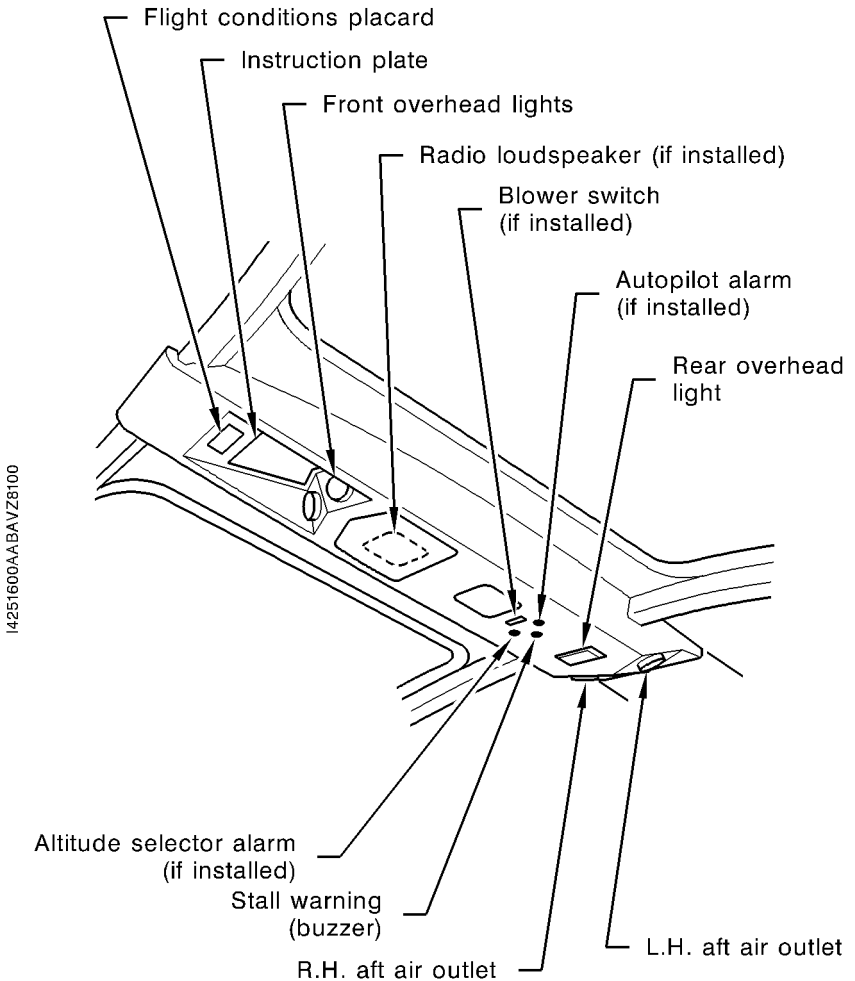
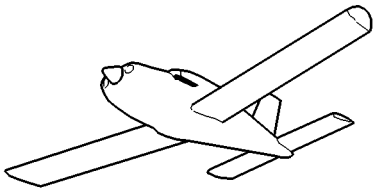

Figure 7.4 - EXAMPLE OF UPPER DUCT CENTRAL PART

ADVISORY PANEL

The advisory panel (see Figures 7.5 and 7.5A) is located at the top edge of the L.H. instrument panel, directly in front of the pilot. The panel contains separate indicator lights which illuminate green, amber or red when a specific condition occurs in the associated airplane system. A green colored light is illuminated to indicate a normal or safe condition in the system. However, an illuminated amber lamp indicates that a cautionary condition exists, but which may not require immediate corrective action. When a hazardous condition exists requiring immediate corrective action, a red light illuminates.

A day / night switch is installed in the centre of the advisory panel to control the intensity of the green indicator lights and of the GPS annunciators (if GPS installed).

Additional annunciators, associated to the GPS (if installed) are installed in the centre of the advisory panel.

SWITCH-BREAKERS PANEL

The general electrical equipment switch-breakers are located on the front part of the central pedestal.

The switch-breakers located on this panel are illustrated in Figure 7.5B.

CIRCUIT BREAKERS PANEL

The electrical equipment circuit breakers are located on a separate panel mounted on the L.H. cabin sidewall adjacent to the pilot.

Circuit breakers located on this panel are illustrated in Figure 7.6.

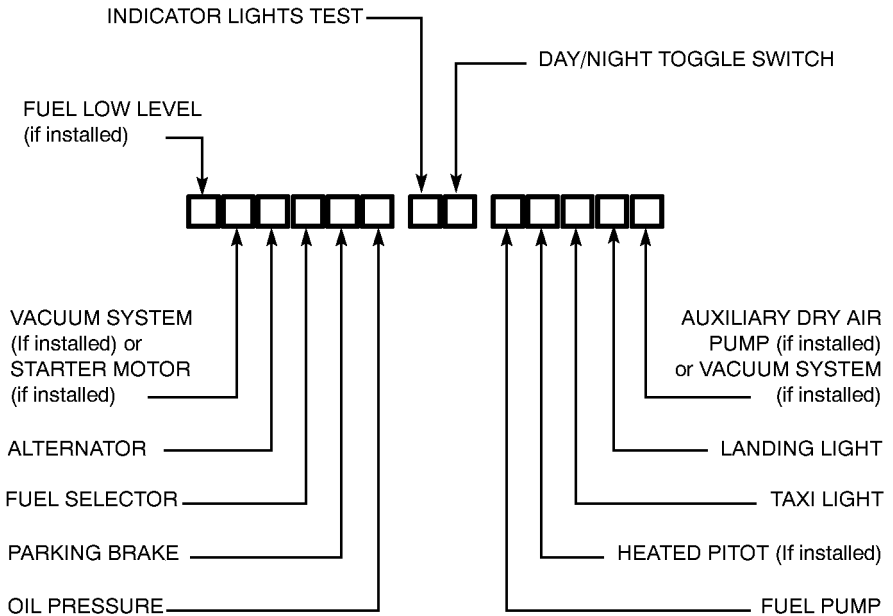
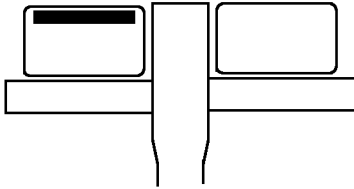
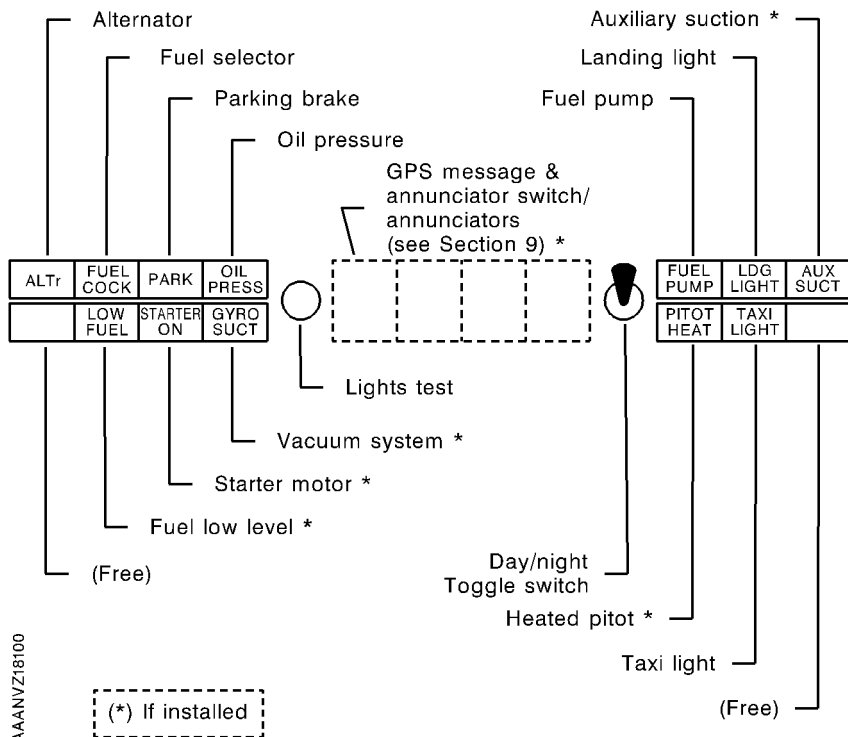
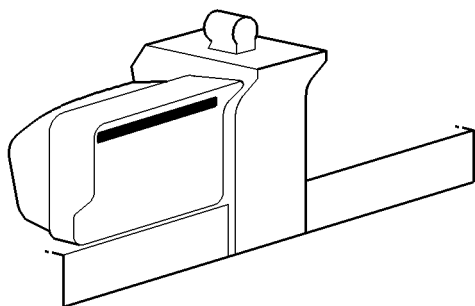
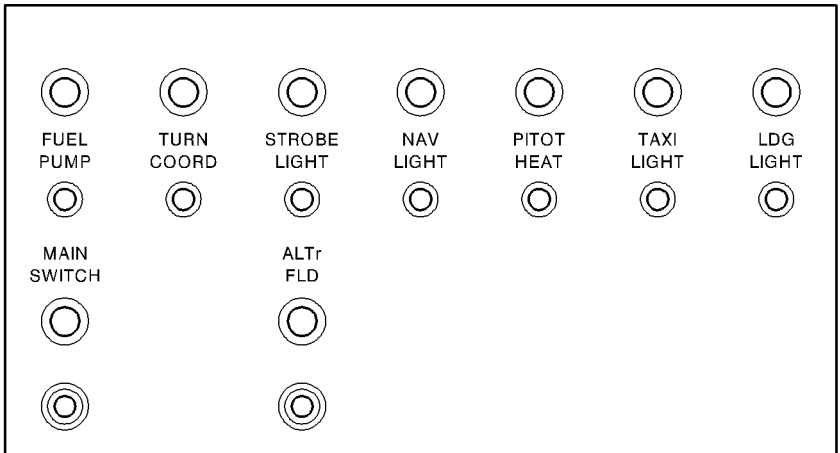
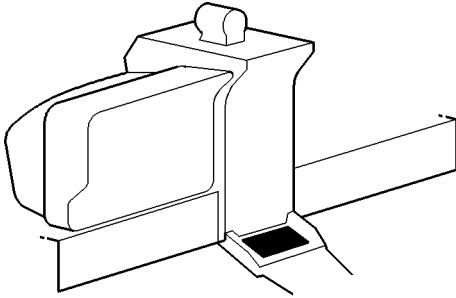

Figure 7.5 - ADVISORY PANEL (BASIC)



14245000AAANVZ18100

Figure 7.5A - ADVISORY PANEL (EXTENDED)



14245000AA CDVZ8100

Figure 7.5B - SWITCH-BREAKERS (SB)

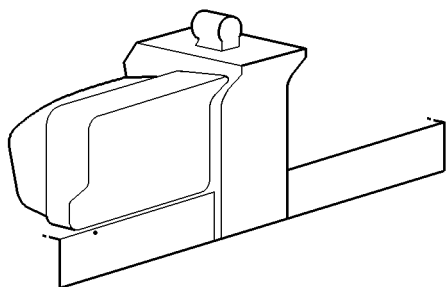

KEY :

Key :

- Circuit breaker (Std)
- ⦿ "Pull off" type circuit breaker (Std)
- Circuit breaker (Opt)
- ⊙ "Pull off" type circuit breaker (Opt)
- △ Switch (Opt)

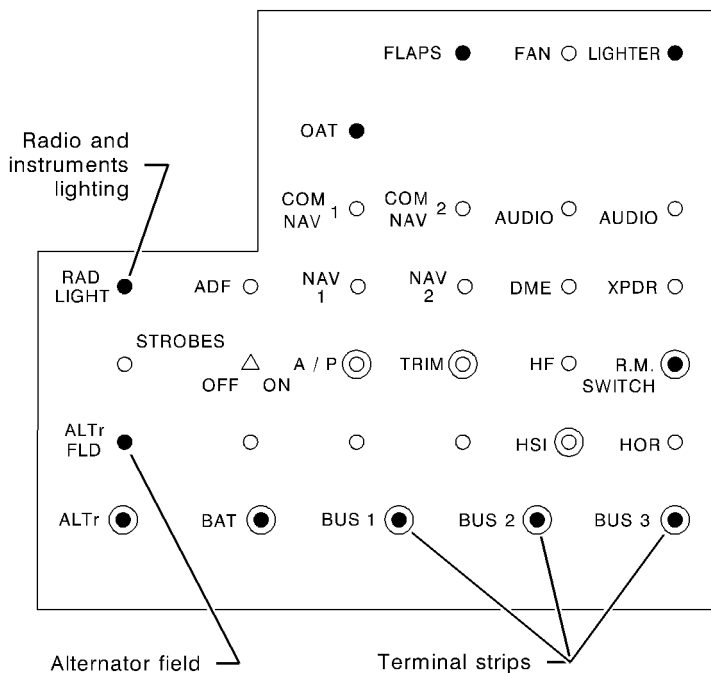
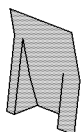

I4245003AAA AEVZ8100

Figure 7.6 - CIRCUIT BREAKERS ASSEMBLY
(Typical arrangement)

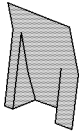
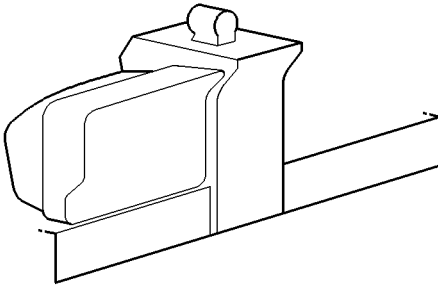

Key :

- Circuit breaker (Std)
- ⊙ "Pull off" type circuit breaker (Std)
- Circuit breaker (Opt)
- ⊙ "Pull off" type circuit breaker (Opt)
- △ Switch (Opt)

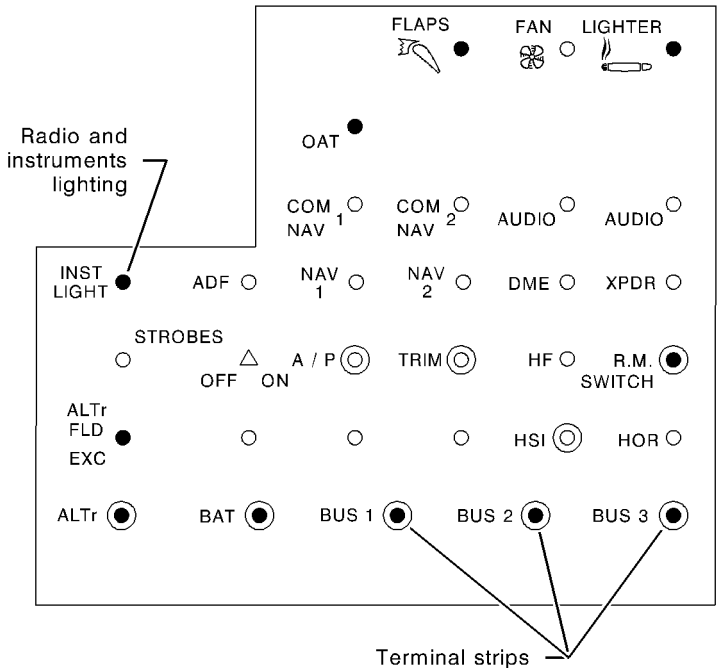

14245003AAAEEVZ18100

Figure 7.6A - CIRCUIT BREAKERS ASSEMBLY
(Typical arrangement)

INTENTIONALLY LEFT BLANK

GROUND CONTROL

Effective ground control while taxiing is accomplished through nose-wheel steering by using the rudder pedals connected to nose-wheel through rods.

When a rudder pedal is fully pushed, the nose-wheel rotates through an arc of approximately 22° to the left and $18^{\circ}30'$ to the right. By applying either left or right brake, the degree of turn may be increased.

The minimum turning radius of the airplane is obtained by using differential braking and nose gear steering (see Figure 7.7).

Moving the airplane by hand is most easily accomplished by attaching a tow bar (stowed in the baggage compartment) to the nose gear leg.

If the airplane is to be towed by vehicle, never turn the nose gear more than 22° to the left and $18^{\circ}30'$ to the right or structural damage to the nose gear could result.

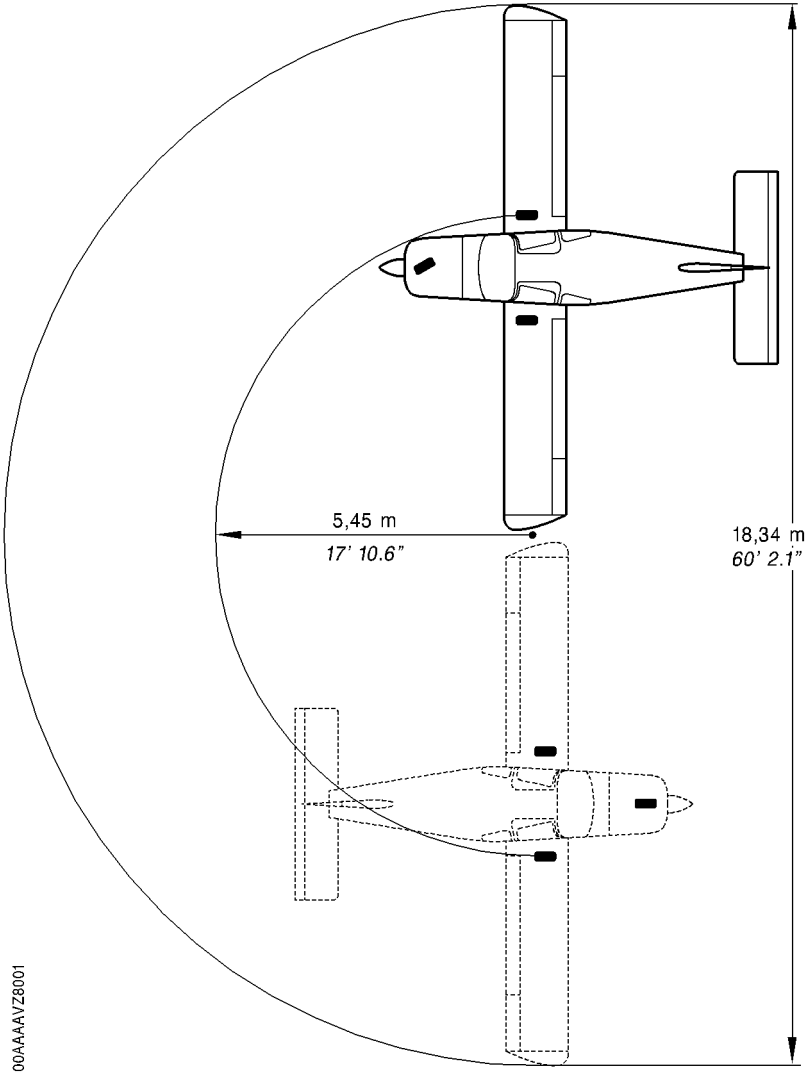

I4062000AAAAYZ8001

Figure 7.7 - MINIMUM TURNING RADIUS

WING FLAPS

The wing flaps are of the large span, single-slot type. They are retracted or extended by positioning to the desired flap deflection position the flaps control located on the pedestal, on R.H. side of the switch-breakers.

The switch lever tilts up or down with stops at 0° and 25°30'. If your aircraft is equipped with pre-setting flaps, the switch lever is moved up or down in a slotted panel with mechanical stops at "retracted" (0°) ; "take-off" (10°) and "landing" (25°30') positions (see Figure 7.2). An indicator located near the control provides various flaps positions.

The wing flaps system is protected by a 8-amp. circuit breaker, labelled "FLAPS" located on L.H. circuit breakers side panel (see Figure 7.6).

LANDING GEAR

Aircraft not equipped with modification MOD. 118 or MOD. 120 :

The landing gear system is of stationary tricycle type with conventional steerable nose gear. Nose gear and main gears are equipped with telescopic and oil / air shock absorbers incorporated in landing gear leg. Each main gear wheel is equipped with a hydraulically-actuated, single-disc brake on the inboard side of the wheel.

Aircraft equipped with modification MOD. 118 or MOD. 120 :

The landing gear system is of stationary tricycle type with conventional steerable nose gear. The nose gear is equipped with a telescopic and oil / air shock absorber incorporated in the landing gear leg. Each main gear includes a rear shock compensating rocker beam connected to the landing gear leg by means of an oil / air shock absorber. Each main gear wheel is equipped with a hydraulically-actuated, single-disc brake on the inboard side of the wheel.

BAGGAGE COMPARTMENT

The baggage compartment extends from the rear bench or, Post-MOD.151, rear seats to the rear bulkhead of the cabin (former No. 6). The access is possible either through a lockable door located on the left side of the airplane, or from the inside of the cabin.

Prior to any flight, check that this door is locked.

To open the access door, proceed as follows :

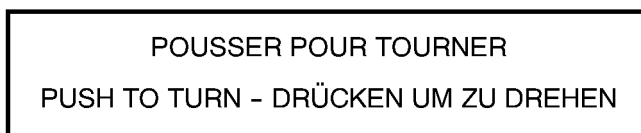

Figure 7.8

WARNING

**ANY PARCEL OR BAGGAGE MUST BE FIXED WITH STRAPS.
IT IS FORBIDDEN TO TRANSPORT PEOPLE IN THE BAGGAGE
COMPARTMENT.**

**ANY MATERIAL THAT MIGHT BE DANGEROUS FOR THE
AIRPLANE OR THE OCCUPANTS SHOULD NOT BE PLACED
IN THE AIRPLANE**

CARGO CONFIGURATION

The rear bench or, Post-MOD.151, rear seats may be taken off for easy loading in cargo configuration. For further information, refer to Section 6 "Weight and balance".

SEATS, SEAT BELTS AND SHOULDER HARNESSSES

FRONT SEATS

The various possibilities of seats adjustment depend on the version chosen.

- To move the seat forward and rearward (*) :
Use the adjustment bar located on the front part of the seat, under the seating and grasp handle under instrument panel strip.
- To tilt the seat (*) :
Use the lever located on the outboard side of the seat.
- To change the seat back angle (if installed) :
Use the knurled knob located at the bottom part on the inboard side of the seat back.
- To adjust the back, at lumbar level (if installed) :
Use the knob located over the knurled knob on the inboard side of the seat back.
Press on the knob and moderately lean back to the desired position, release the button, the seat back should fit perfectly with your back.

(*) Lift up adjustment bar or lever to unlock ; when in desired position, release it and make sure it is locked.

REAR BENCH OR, Post-MOD.151, REAR SEATS

- To remove rear bench or rear seats, refer to Section 6 "Weight and Balance".
Rear bench or rear seats is/are not adjustable.

HEAD-RESTS (if installed)

- Before Model "95" :
 - . To adjust and remove the head-rest :
Simply make it slide vertically.
 - . To fit the head-rest into the seat back :
Turn the centering bush (bearing an arrow) of ¼ turn clockwise (in the arrow direction) and maintain it to fit the head-rest in the seat back.
- Model "95" :
 - . To install, adjust and remove the head-rest, simply make it slide vertically.

"STANDARD" VERSION
Pre-MOD.151

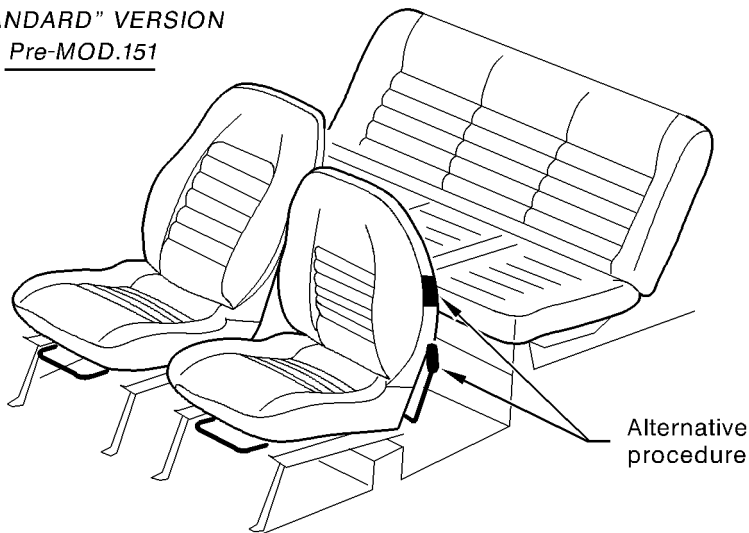

Alternative procedure

"LUXE" AND
"EXECUTIVE" VERSIONS

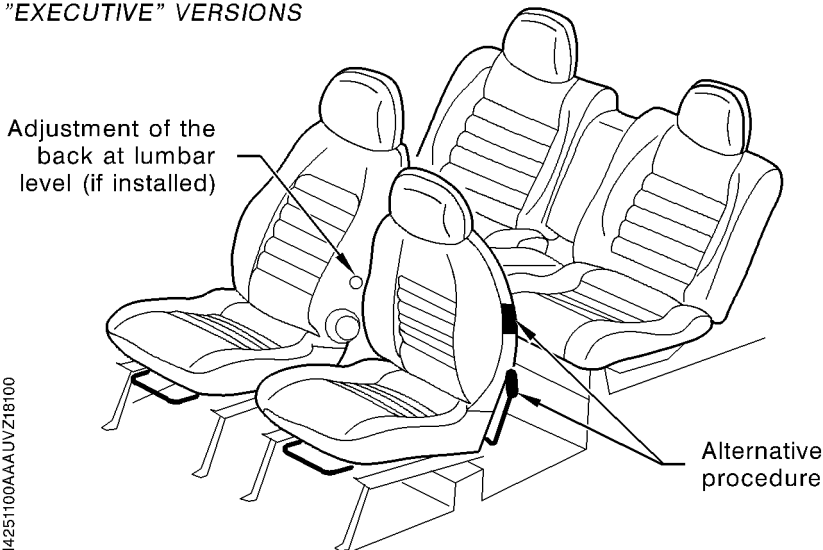

Alternative procedure

Figure 7.9 - FRONT SEATS AND REAR SEAT

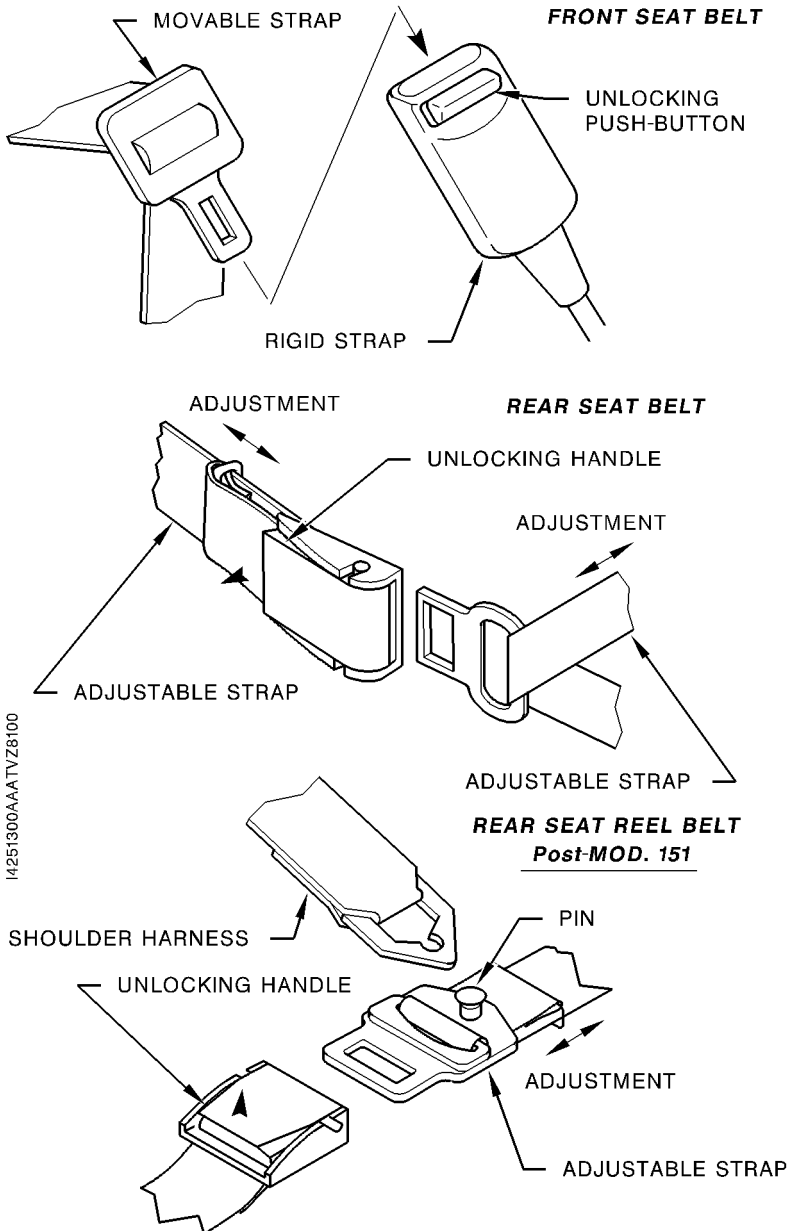

Figure 7.10 - SEAT BELTS

SEAT BELTS (see Figure 7.10)

RECOMMENDATIONS

Misuse of the safety belt may introduce a risk.

Be sure the belt is tightened when it is fastened.

To be effective, the seat belt shall not be twisted.

In any case and for all types of belts, check that they are not impeded in their operation.

Further to a severe accident, replace the belts which were installed when the accident happened.

Front seat belts

- To lock them :
Engage movable strap into rigid strap up to clipping.
Should a blocking occur during operation, slightly ease back [5 in. (10 cm) approximately], then unwind strap again.
- To unlock them :
Depress red unlocking push-button to free movable strap.

Rear seat belts

- To lock them :
Engage both straps up to clipping.
Be sure the belt is properly tightened (adjustment is possible on both straps).
- To unlock them :
Pull on unlocking handle to release straps.

Post-MOD.151

Rear seat reel belts

- To lock them :
Engage reel shoulder harness rigid part on adjustable strap pin. Then engage straps so attached in the locking handle up to clipping.
Be sure the belt is properly tightened.
- To unlock them :
Pull on unlocking handle to release straps.
Disengage shoulder harness rigid part from the pin.

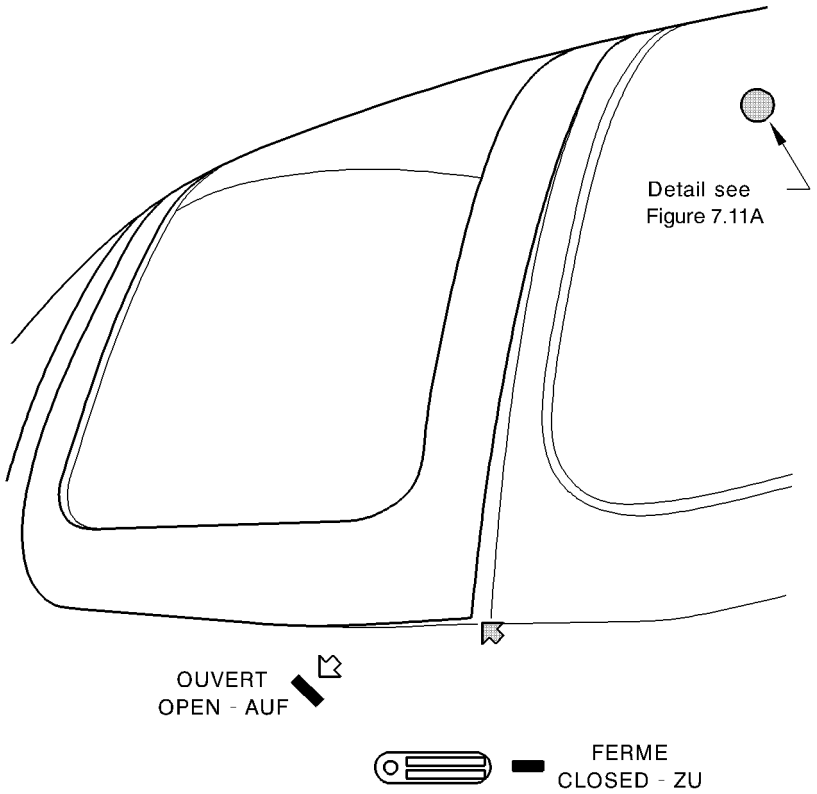

Figure 7.11 - DOORS OPENING AND CLOSING



Figure 7.11A - EMERGENCY EXIT - Pre-MOD.151

I4521000AACCTY8100

DOORS AND EXITS (see Figure 7.11)

DOORS

- To open them :
Push handle forward.
Lift the door at the location marked with a shaded arrow.
Follow door up to maximum position.
- To close them :
Close the door and set handle to "Closed" position .

WARNING

**PRIOR TO EACH FLIGHT, CHECK THAT BOTH CABIN
ACCESS DOORS ARE NOT KEY-LOCKED**

**CHECK THAT BOTH LOCKING HOOKS ARE
PROPERLY NOTCHED**

EXITS

■ Pre-MOD.151

In case of L.H. and R.H. doors locking, and if it is necessary to leave the airplane in a hurry (risks of fire, drowning...) jettison one or both rear windows, kicking out at the location of the placard.

The placard (see Figure 7.11A) is located on both rear windows and is legible from the inside of the airplane.

CONTROLS LOCK

A locking pin located in lateral case on pilot's side is provided to block the control wheel.

To insert the blocking pin into the control wheel tube pull the control wheel backwards to approximately half-way and line up the tube hole with that of the fixed part on the panel. The blocking pin will be inserted vertically from top to bottom.

A safety device preventing the introduction of the magneto/start selector key forbids operation of the engine with blocked control wheel.

Pull the blocking pin upwards to free the control wheel and the magneto/start selector.

ENGINE

The TB 10 airplane is powered by a four-cylinder, horizontally opposed, direct drive LYCOMING O-360-A1AD engine rated at 180 BHP at 2700 RPM. It is provided with a starter, a 24-volt / 70-amp alternator, an all-weather shielded ignition harness, a dual magneto, a vacuum pump drive, a fuel pump and a manifold air filter.

The engine cowl is a laminate cantilever structure, fixed on the firewall and made of two elements. The upper cowl is fitted with an inspection door provided to check oil level ; it can also be fitted with an access door to the propeller deicing fluid tank. The lower cowl is fitted with incorporated air intakes and may be fitted with an inspection door to easy quick drain. Both cowls are completely removable without requiring removal of the propeller.

The engine mount is made of steel tube, rigidly attached on firewall. Engine attachment is provided by dynafocal mounting brackets to attenuate vibrations.

Engine and accessories cooling is provided by a downwards airflow. Air penetrates through holes located on each side of the propeller cone, is guided around the engine by airproof deflectors, then conducted to two air outlets located on the lower cowl.

Engine inlet air penetrates through an air intake located on the left side of the lower cowl and goes directly through a filter, before being admitted in the air duct under the carburetor. The air duct comprises an alternate air intake with mechanical closing, the purpose of which is to supply the carburetor with heated air when the airplane is involuntary in icing conditions.

The stainless steel exhaust system comprises a silencer with a heat exchanger in order to provide cabin hot air supply. Exhaust gases are evacuated through the exhaust duct at the basis of engine lower cowl, on R.H. side.

In order to obtain the maximum engine performance and T.B.O, the pilot should apply the procedures recommended by Lycoming Operator's Manual concerning the engine.

ENGINE CONTROLS

- Engine manifold pressure is controlled by the throttle (large black knob) located on the control pedestal. In the forward position, the throttle is open (full power) ; in the aft position, it is closed (engine idling).
- The propeller governor is controlled by the propeller control (blue notched knob) located on the central pedestal. In the forward position, the propeller moves to "low pitch" position (high RPM), in the aft position, it moves to "high pitch" position (low RPM).
- The mixture is controlled by the mixture control (red notched knob) located on R.H. side of the central pedestal. In the forward position, the mixture is open (full rich) ; in the aft position, the mixture is closed (idle cut-off).
- - The carburetor air temperature is controlled by the carburetor heating control (grey round knob) located on the control pedestal on the L.H. side. If control lever is in forward position, the outside temperature air is carried through the air filter to the carburetor, if in the aft position, exchanger heated air, mixed with outside temperature air, is directly carried to the carburetor.
- - Engine controls friction is controlled by a knurled knob located in the alignment of the controls on the R.H. side of the pedestal.

ENGINE INSTRUMENTS

Indicators enable the pilot to assure a permanent check of fuel pressure, oil pressure, oil temperature, tachometer and (if installed) EGT and CHT.

Post-MOD.182

A "TEST" knob, located on the engine monitoring cluster front face, enables to test :

- digital indicators,
- analogue indicators (pointers at 12 o'clock),
- lamps (VDC, AMP and PSI),
- equipment both power supplies are available. In case of loss of one of the power supplies, the yellow lamp (AMP) flashes during the test.

IGNITION - STARTER SYSTEM

Engine ignition is provided by two magnetos and two spark plugs per cylinder.

The R.H. magneto fires the R.H. lower and L.H. upper spark plugs ; the L.H. magneto fires the L.H. lower and R.H. upper spark plugs.

Ignition is controlled by a key-operated rotating selector, located on L.H. side of the L.H. panel strip.

The selector operates clockwise : "OFF" ; "L.H." magneto ; "R.H." magneto ; "L.H. + R.H." magnetos ; "STARTER" by pushing.

CAUTION

**RELEASE THE PRESSURE ON THE KEY
AFTER ENGINE START**

NEW ENGINE BREAK-IN AND OPERATION

The engine has undergone a break-in at the factory and is ready for the full range of use. It is, however, recommended that cruising flights be accomplished at 65 to 75 % until a total of 50 hours has accumulated or oil consumption has stabilized.

However for new, remanufactured or recently overhauled engines, as well as engines on which cylinders have been recently installed, it is required to perform according to **TEXTRON LYCOMING Service Bulletin No. 480** at last revision the following inspections :

- an inspection within the 10 first flight hours,
- an inspection within the 25 following flight hours.

Use dispersant oil in compliance with Specification MIL-L-22851 only after the first 50 hours.

ENGINE LUBRICATION SYSTEM

The engine is lubricated by an oil system powered by a pump located on engine rear accessory housing. A sump located at the bottom of the engine allowing oil recovery, a cartridge throw-away type filter located on engine rear accessory housing and a strainer type filter located in the sump complete the system.

A pressure probe and a temperature probe transmitting the values to two indicators located on upper edge of the console enable the pilot to check the oil system.

An inspection door located on engine upper cowl provides access to oil system filling port.

A dipstick attached on the port blanking cap enables to check oil level in the sump. A union located under the engine case enables a quick drain of the latter.

AIR INDUCTION SYSTEM

The engine is supplied with an air intake located on the L.H. side of the lower cowling. This air intake is fitted with a filter which removes dust and other foreign matters from the induction air so that they do not penetrate into the air duct. However, in the event the air filter becomes blocked, place carburetor heating control in the ON position to open an alternate air door allowing air to enter the engine.

For flights in sandy or dusty atmosphere, install a second specific filter.

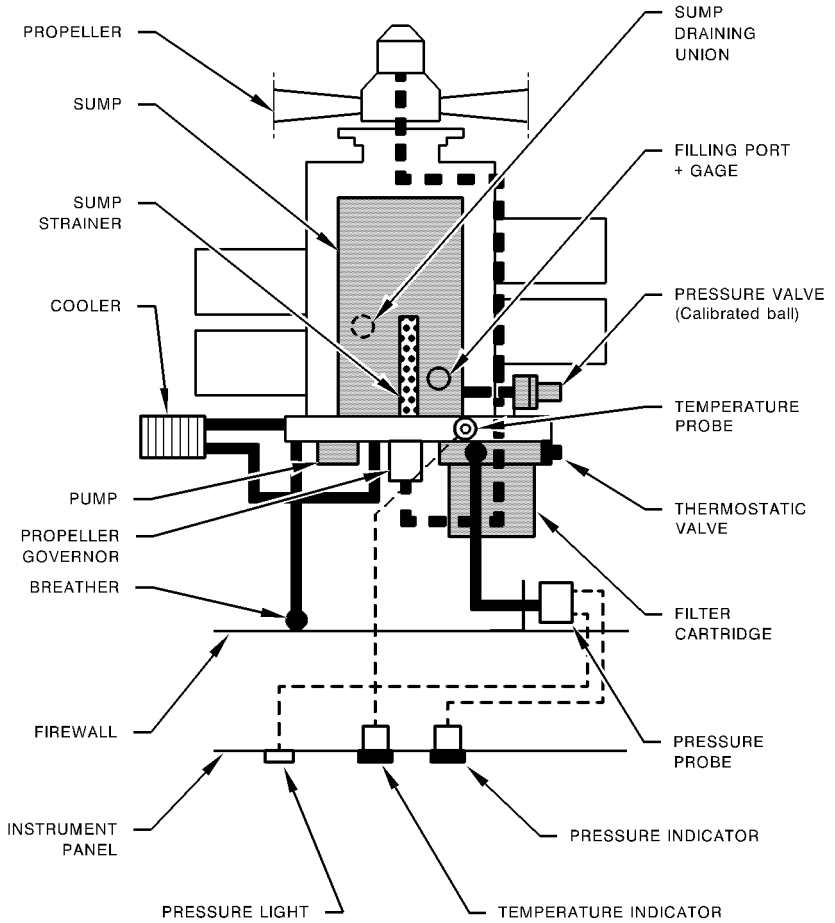

I4790000AAA4KVZ8100

Figure 7.12 - OIL SYSTEM

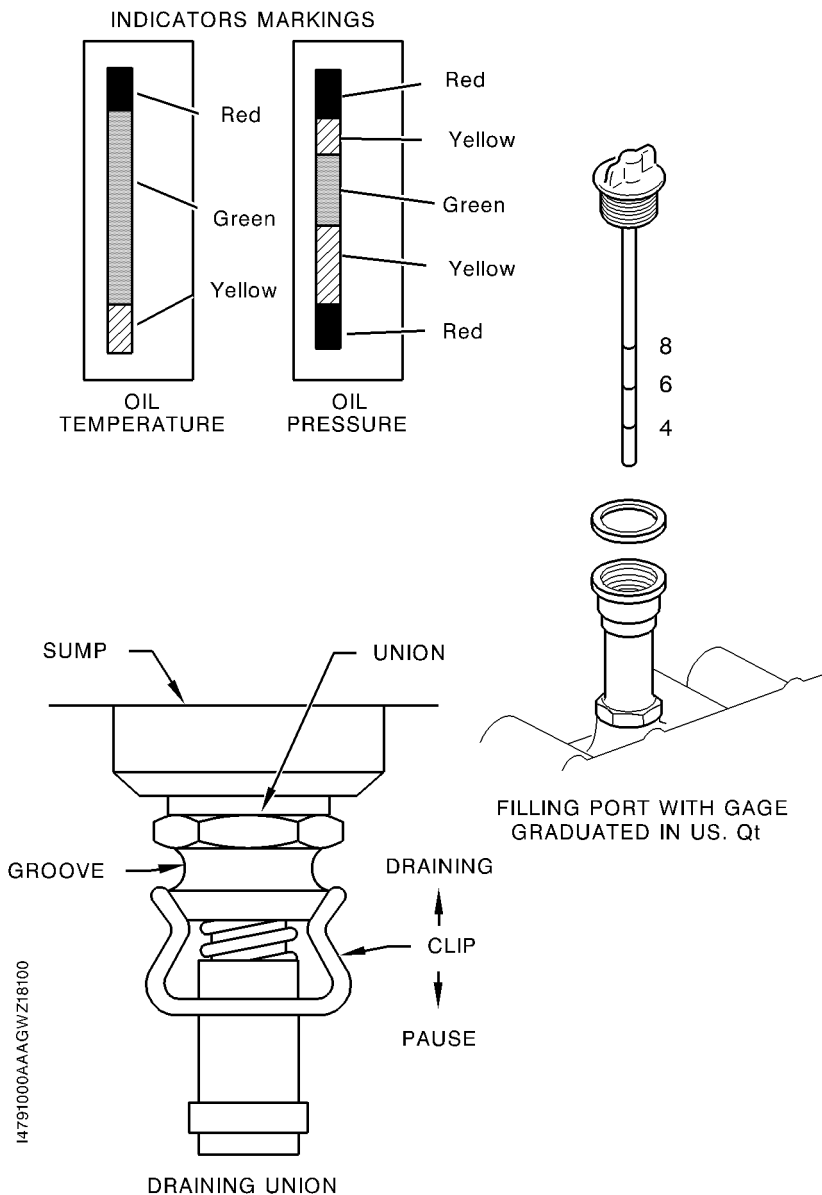

Figure 7.12A - OIL SYSTEM

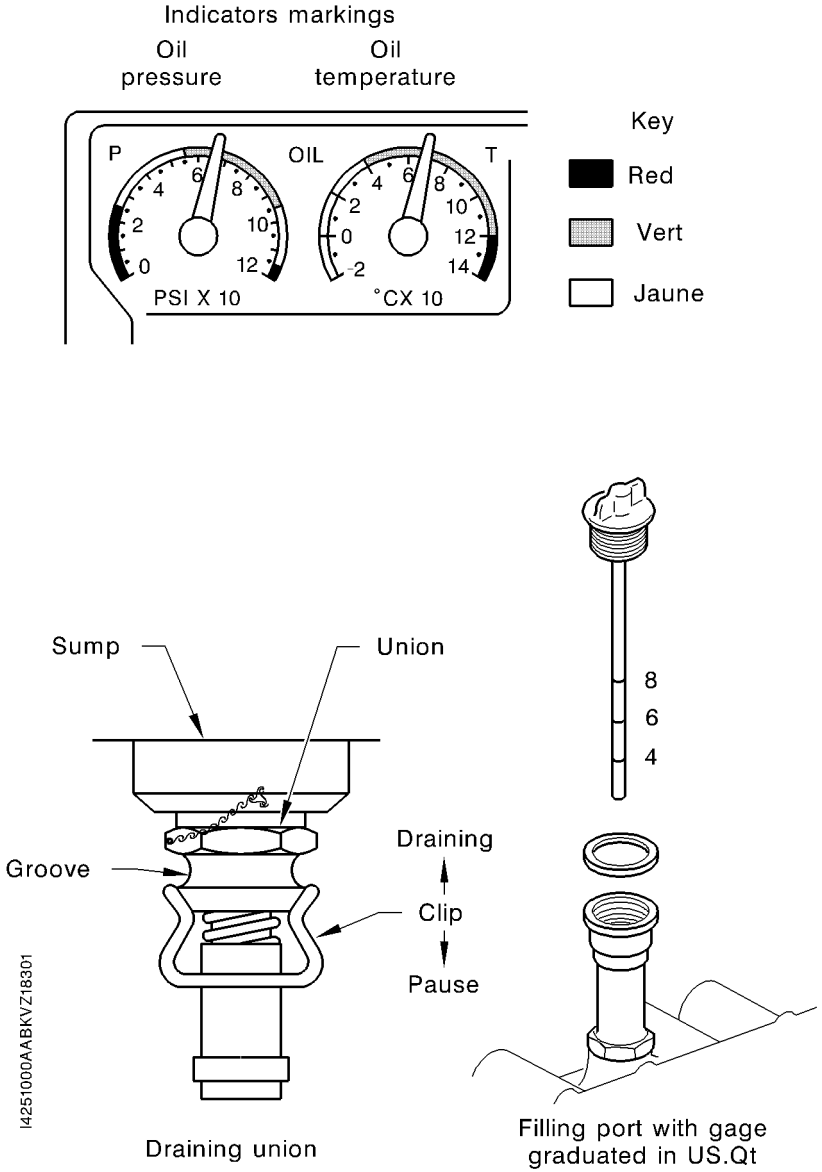

Figure 7.12B - OIL SYSTEM

INTENTIONALLY LEFT BLANK

EXHAUST SYSTEM

Exhaust gas from each cylinder is collected by pipes to be conducted, in order to reduce its noise level to an exhaust duct which vents it outboard on R.H. side of lower engine cowl.

PROPELLER

The airplane is fitted with all-metal, two-bladed, constant-speed, governor-regulated propeller. The propeller control actuates on the governor. According to the control position, the governor determines propeller rotation speed, and thus the engine speed to be maintained. The governor controls flow of engine oil, boosted to high pressure by the governing pump, on a piston located in propeller hub. Oil pressure twists the blades toward high pitch (low RPM). When oil pressure to the piston is relieved, the blades twist to low pitch (high RPM).

FUEL SYSTEM

The fuel system (see Figures 7.13 and 7.14) consists of two vented integral fuel tanks (one in each wing), a selector valve, a filter, an auxiliary fuel pump as well as an engine-driven fuel pump and a carburetor.

Engine-driven fuel pump suction draws fuel from L.H. or R.H. tank through the three-position selector valve and a filter.

The selector valve is controlled through a knob labelled "FUEL SELECTOR"

The selector valve knob has following positions labelled : "CLOSED", "LEFT", "RIGHT".

Then, the fuel goes through the auxiliary fuel pump (electric) and supplies the engine fuel pump. The engine pump supplies fuel under pressure to the carburetor.

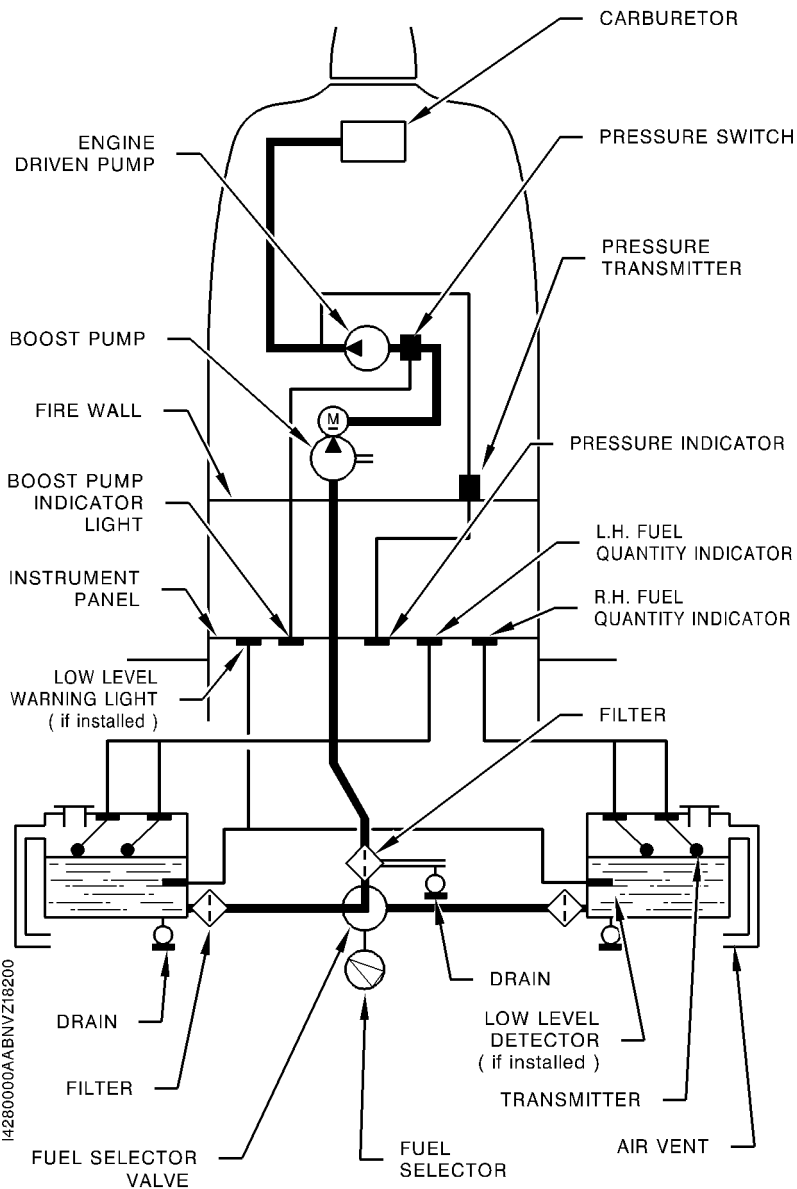

Figure 7.13 - FUEL SYSTEM

Fuel quantities :

- Total maximum : 55.4 U.S Gal. (210 l)
- Total usable : 53.9 U.S Gal. (204 l)
- Unusable : 1.6 U.S Gal. (6 l)

In cruise flight, a continuation of fuel flow must be assured as the new tank is being selected. When switching from one tank to the other, place the auxiliary fuel pump switch momentarily in the "ON" position until normal fuel flow has been restored.

Each fuel tank is equipped with its own ventilation system, an essential element in the operation of the fuel system. Should a vent become blocked, the fuel flow from the tank concerned is reduced and the engine may cut out. The ventilation is ensured by ducts which run to the lower surface of each wing.

Fuel quantity is measured by four fuel quantity gages and is shown by two fuel quantity indicators located on the upper portion of the central console.

Airplanes equipped with resistor/float gages

The float type gages, two on each wing, are attached to the rear of the tanks.

Airplanes equipped with capacity gages

The capacity type gages, two on each wing, are attached to the rear of the tanks, on the wing spar.

Fuel quantity measured by the gages is transmitted to the fuel quantity indicators by a gaging conditioner located under the seating of the rear bench or, Post-MOD.151, the rear seats.

All

The indicators are graduated in 1/4, 1/2, 3/4 and 4/4, with the zero indicating an empty tank. When the pointer of the indicator is at zero, approximately 0.8 U.S. Gal (3 litres) of unusable fuel remains in the tank.

The indicators cannot be relied upon for accurate readings during skids, slips or unusual attitudes. If both indicator pointers should rapidly move to a zero, check voltmeter and oil temperature indicators. If they are not indicating, an electrical malfunction has occurred.

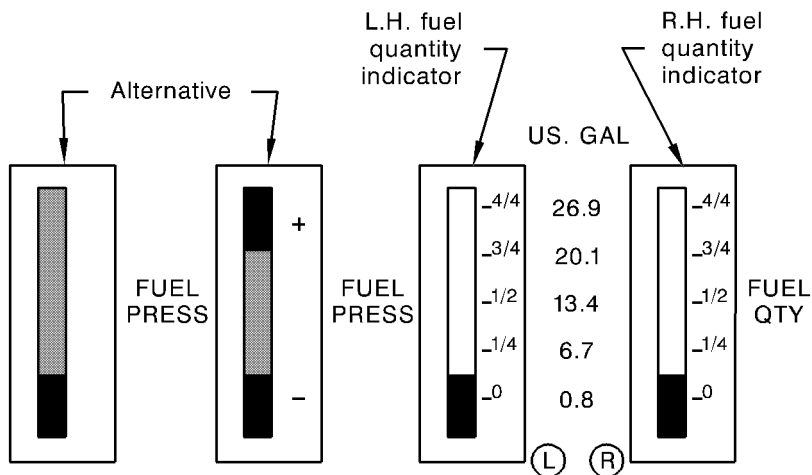
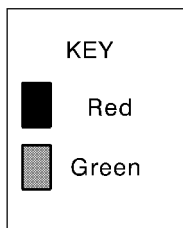
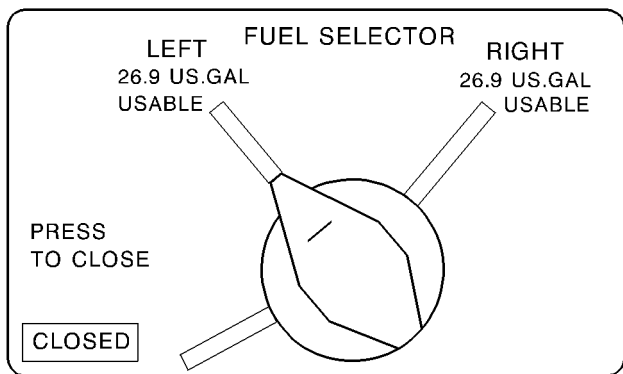

14284000AA CKVZ18300

Figure 7.14 - FUEL SYSTEM MARKINGS (U.S. Gallons)

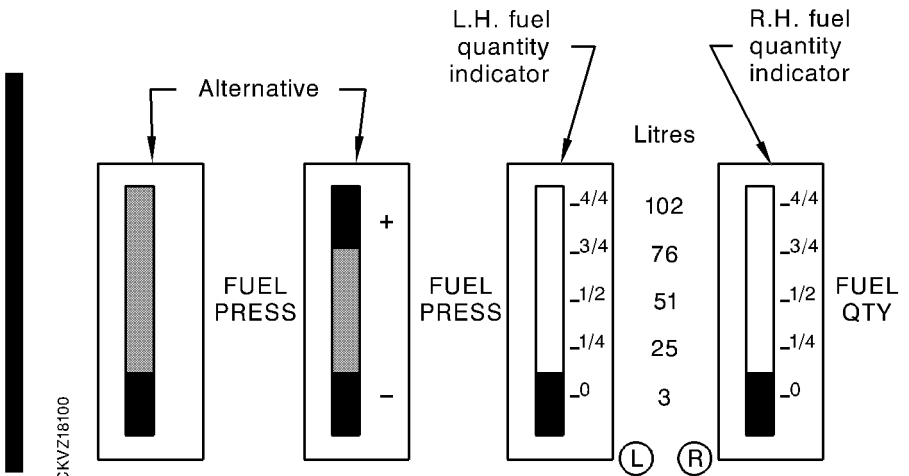
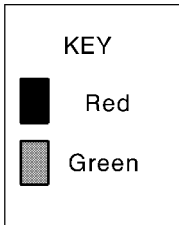
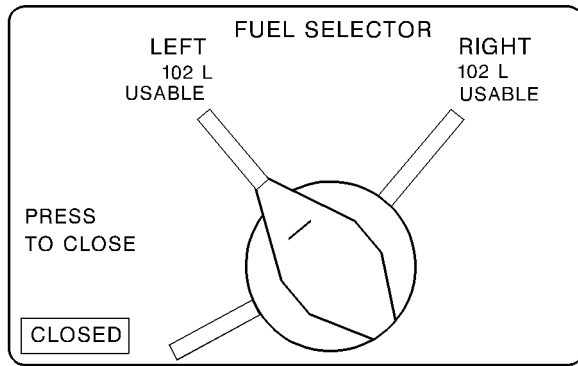

14284000ACKYZ18100

Figure 7.14A - FUEL SYSTEM MARKINGS (Litres)

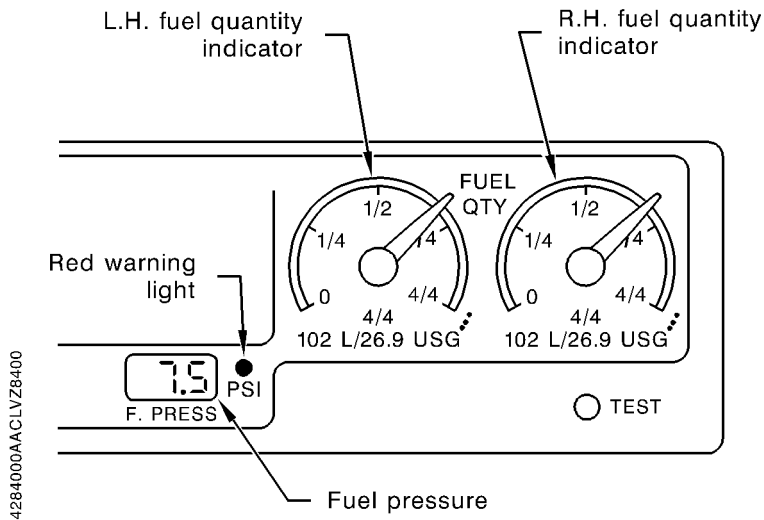
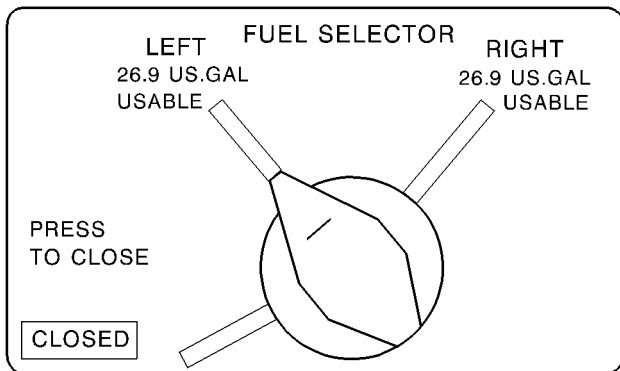

Figure 7.14B - FUEL SYSTEM MARKINGS (U.S. Gallons)

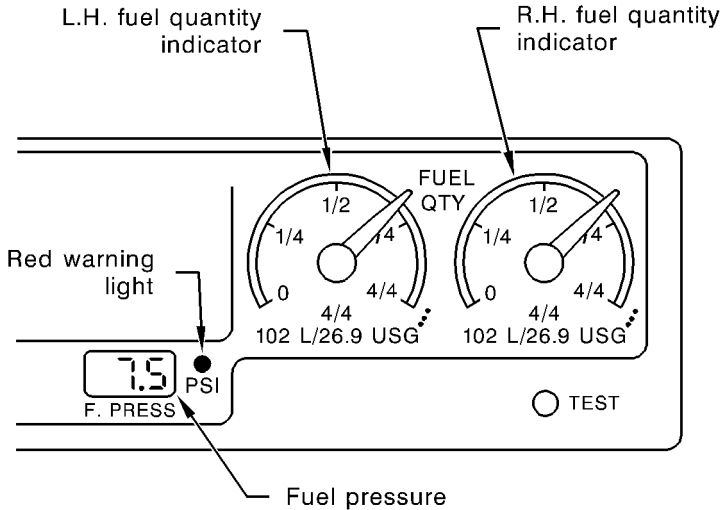
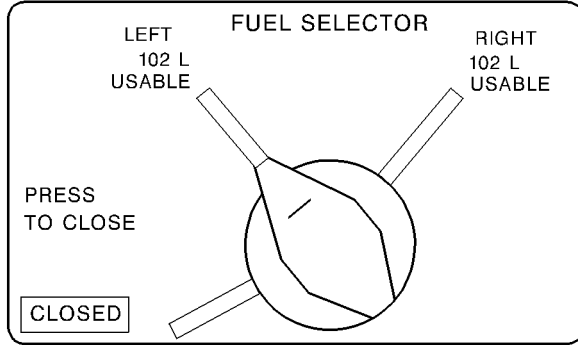

Figure 7.14C - FUEL SYSTEM MARKINGS (Litres)

INTENTIONALLY LEFT BLANK

Post option C866 00M or Post-MOD.151

A low level warning light, located on the advisory panel, comes on whenever usable fuel quantity, remaining in one of both tanks, (airplane in line of flight) reaches approximately 6.6 U.S. Gal (25 litres). In this configuration, the warning light illumination is controlled by a low level detector, located in each tank.

Post-MOD.171

A dual low level warning light, located on the L.H. instrument panel, receives information from R.H. and L.H. fuel tanks.

The warning light corresponding to the wing comes on whenever usable fuel quantity (airplane in line of flight) reaches approximately 6.6 U.S. Gal (25 litres). In this configuration, the warning light illumination is controlled by a low level detector, located in each tank.

All

The auxiliary fuel pump is controlled by a switch-breaker located on front part of pedestal.

An indicator light located on the advisory panel shows operation of the auxiliary pump.

The fuel system is equipped with drain valves to provide a means for the examination of the fuel in the system for contamination and grade. The system should be drained every day before the first flight and after each refueling by using the fuel sampler provided to drain fuel from the wing tank sump drain and the fuel strainers drains. The fuel tank sump drains are located just outboard of each main landing gear well and the fuel strainer drain is located under the R.H. front fuselage, near its intersection with R.H. wing.

The fuel tanks should be filled after each flight to minimize condensation, respecting the weight and balance limits.

The tanks are provided with a gage visible from the filling port.

Fuel tanks are full (fuel level not marked on the gage) when fuel is at the level of the filling port.

BRAKE SYSTEM

BRAKING

Braking is provided by hydraulic disk brakes actuated by brake pedals located on the L.H. station rudder pedals.

The R.H. station may also be equipped with brake pedals.

Differential braking helps to maneuver during taxiing :

- L.H. pedal actuates the L.H. wheel brake,
- R.H. pedal actuates the R.H. wheel brake.

PARKING BRAKE

- Parking brake is constituted with a knob located on the lower section of the L.H. strip, actuating a valve.
- To apply the parking brake, depress the pedals and turn the parking brake knob rightward.
- To release the parking brake, depress the pedals and set knob again in its vertical position (turn it leftward).
- An indicator light located on the advisory panel shows the position of the parking brake knob.

NOTE :

Operating the brake knob does not cause the parking brake to operate.

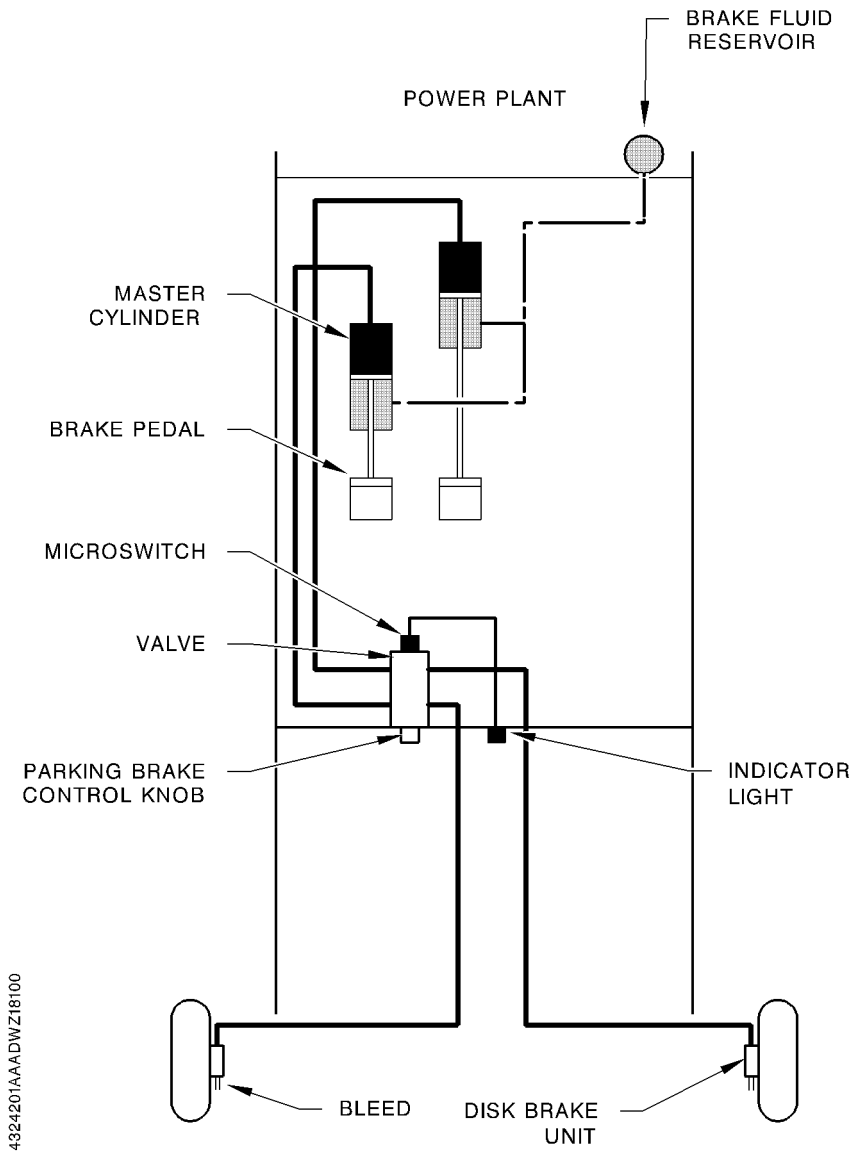

14324201AAADWZ18100

Figure 7.15 - BRAKE SYSTEM (L.H. station only)

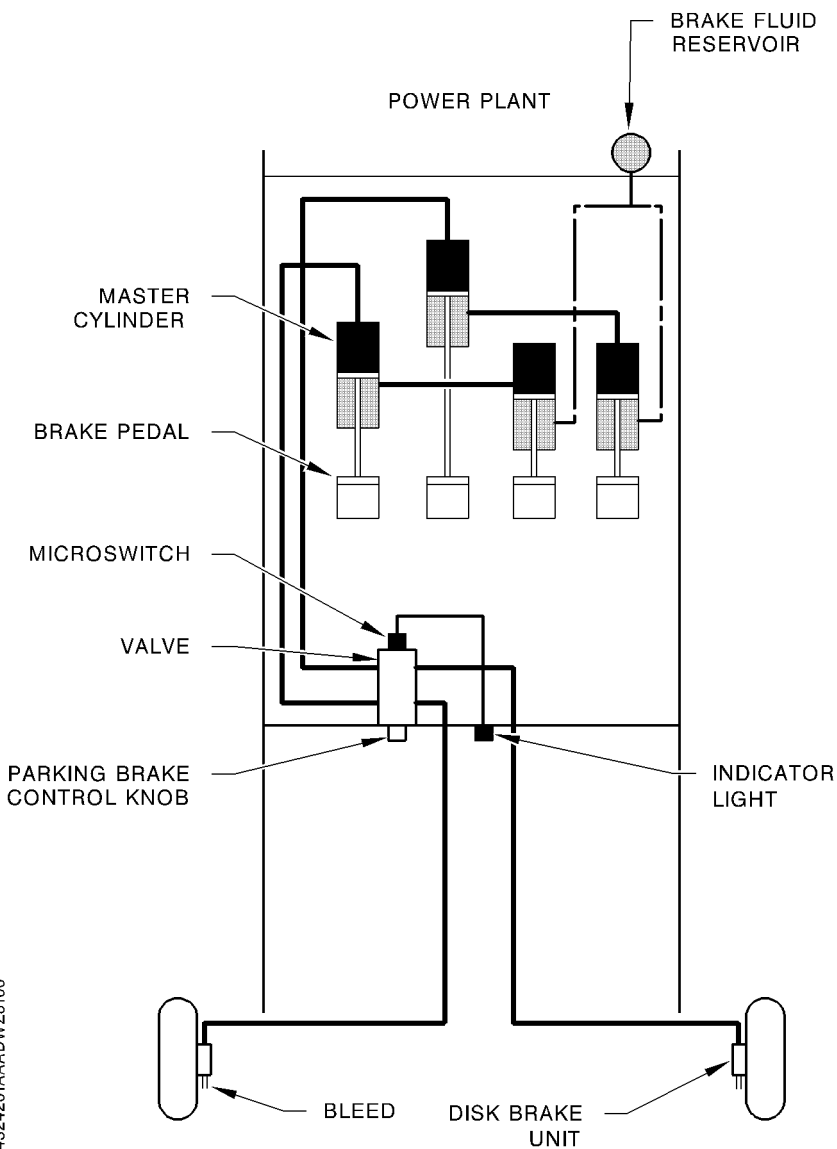

14324201AAA DWZ8100

Figure 7.15A - BRAKE SYSTEM (L.H. + R.H. stations) (if installed)

STANDARD ELECTRICAL SYSTEM

The airplane is equipped with a 28-volt, direct-current electrical system (see Figures 7.16 and 7.16A). A belt-driven 70-amp alternator installed on the engine and a battery located in the engine compartment on firewall R.H. side supply the system.

The alternator is controlled by an alternator control unit providing voltage regulation, plus overvoltage sensing.

A "pull-off" type circuit breaker calibrated at 60 amps limits the alternator electrical load to the battery and the networks.

ALTERNATOR CONTROL UNIT

The alternator control unit located on the firewall, on cabin side provides the alternator voltage regulation and overvoltage protection.

In the event of overvoltage, the alternator control unit cuts off the alternator field and the amber (red on UK airplanes) warning light labelled "ALTr" illuminates. In this case only the battery powers the airplane mains.

The reset of the alternator control unit is operated by disconnecting and closing the switch-breaker labelled "ALTr FLD".

MAIN SWITCH

Battery connection to the electrical network is made through the switch-breaker labelled "MAIN SWITCH".

Before connecting ground power receptacle (if installed) on external power unit, check that main switch is OFF.

ALTERNATOR CONTROL

Located on the R.H. side of the main switch, the alternator switch-breaker labelled "ALTr FLD" controls the operation of the alternator through the regulator.

In the event of an alternator disconnection, should the flight be continued, only the necessary electrical equipment will be used.

The tripping of "MAIN SWITCH" and "ALTr FLD" switch-breakers in flight cuts off simultaneously all electrical power supplies.

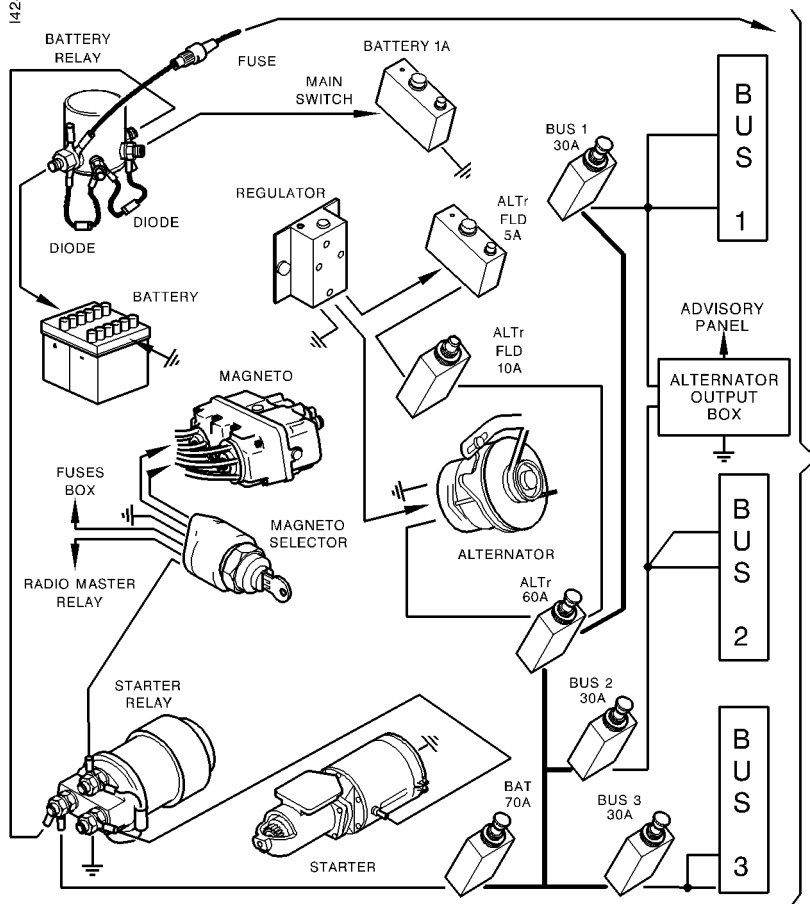
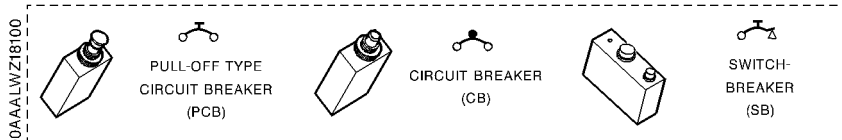

Figure 7.16 - TYPICAL ELECTRICAL SYSTEM

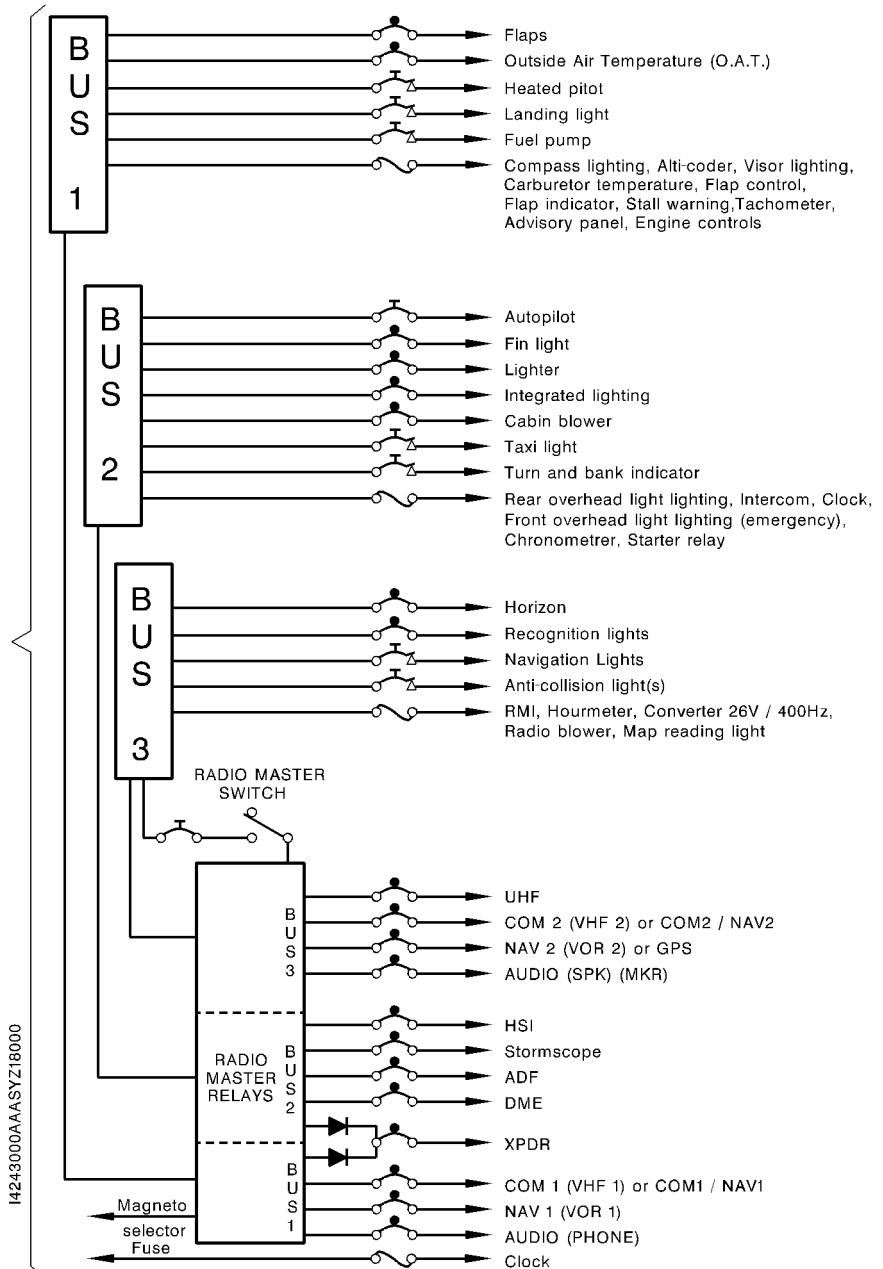

Figure 7.16A - TYPICAL ELECTRICAL SYSTEM

INTENTIONALLY LEFT BLANK

AVIONICS POWER SWITCH (if installed)

A switch labelled "RADIO MASTER" is installed on R.H. side of the L.H. strip to control power supply to avionics and enables automatic disconnection of avionics systems when the engine starts, or manual disconnection during abnormal conditions.

When the switch is in OFF position, no electrical power will be applied to the avionics equipment. The avionics power switch "RADIO MASTER" should be placed in the OFF position prior to turning main switch ON or OFF, or applying an external power source and may be utilized in place of the individual avionics equipment switches.

- The opening of the "R.M. SWITCH" circuit breaker enables to inhibit the "RADIO MASTER" switch operation, and so to recover the power supply of the radio set in case of faulty operation of the "RADIO MASTER" switch.

"RADIO MASTER" function does not concern some optional equipment such as electric trim, autopilot, HF transceiver...

VOLTMETER

A voltmeter is incorporated to the engine control instruments module, located on the upper part of the console, to monitor electric generation system efficiency.

With the alternator operating, the indication must stabilize in the green sector.

With the alternator off, indication may go down to the yellow sector.

If indication is within lower red sector, remove and charge the battery.

If indication is within the upper red sector with the alternator operating, the regulator has to be adjusted.

I4311003AAAADWZ8100

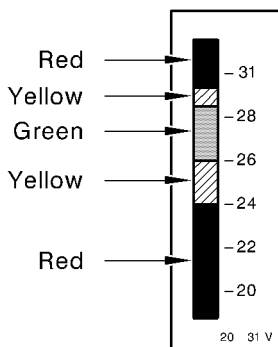

Figure 7.17 - VOLTMETER MARKING

AMMETER (if installed - standard equipment for "BRAZIL")

The ammeter indicates current flow, in amperes, from the alternator to the battery, or from the battery to the electrical system. With the engine operating and master switch "ON", the ammeter indicates the rate of charge being applied to the battery.

VOLTMETER AND AMMETER

A digital indicator displaying the voltmeter or ammeter data is incorporated to the engine monitoring cluster, located on the upper part of the console. A switch, located on L.H. side of this indicator, enables to select either the voltmeter function (V) or the ammeter function (A).

Voltmeter

The main function of the voltmeter is to monitor electric generation system efficiency.

With the alternator operating, the indicated value must stabilize between 26 and 29 Volts. With the alternator off, the indicated value may decrease below 24 Volts.

Red LED (VDC), located on the indicator R.H. side, illuminates for a voltage greater than 30.4 Volts or lower than 24 Volts :

- Illuminated LED with displayed voltage lower than 24 Volts :
 - . engine stopped : voltage lower than 22 Volts, remove and charge the battery,
 - . engine running : check alternator regulator system.
- Illuminated LED with displayed voltage greater than 30.4 Volts :
 - . check alternator regulator system.

Ammeter

The ammeter indicates current flow in amperes from the alternator to the battery or from the battery to electrical systems.

Yellow LED (AMP), located on indicator R.H side, illuminates when battery is discharging.

I4251000AABLZ8400A

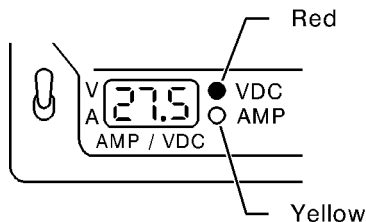

Figure 7.17A - VOLTMETER OR AMMETER MARKING

INTENTIONALLY LEFT BLANK

CIRCUIT BREAKERS AND FUSES

Most of electrical circuits are protected by circuit breakers installed on the L.H. side panel, adjacent to the pilot. Should an overload occur on a circuit, the circuit breaker trips and will switch off the circuit. Allow it to cool for three minutes approximately, then the circuit breaker may be closed again (pressed down).

Avionics equipment are protected by circuit breakers grouped in the lower part of the L.H. side circuit breakers panel.

In addition to protection of the alternator supply with a 60-amp pull-off type circuit breaker labelled "ALTr", the following pull-off type circuit breakers have been installed :

- 70 A labelled "BAT" between battery and network
- 30 A labelled "BUS 1" on bus bar 1 supply
- 30 A labelled "BUS 2" on bus bar 2 supply
- 30 A labelled "BUS 3" on bus bar 3 supply

These five pull-off type circuit breakers are manually-operated and can isolate the various sources or bus bars.

Fuses located on L.H. firewall door protect following circuits (from left to right) :

Upper row : advisory panel, spare, advisory panel, compass lighting, rear cabin light, starter relay, electric tachometer, emergency lighting,

and if installed : carburetor temperature, RMI, converter 26 V/400 Hz, radio fan, spare.

Lower row : engine monitoring cluster, engine monitoring cluster, spare, flap indicator, flap control, stall warning, visor lighting,

and if installed : chronometer, intercom, clock, alti-coder, maps light, spare, hourmeter, spare.

■ "ALTr" WARNING LIGHT (LOW VOLTAGE)

Anytime electrical system voltage falls below approximately 26 volts, as directly sensed by the distribution systems, an amber (red on UK airplanes) warning light labelled "ALTr" illuminates on advisory panel to warn the pilot.

■ GROUND POWER RECEPTACLE (if installed)

A ground power receptacle permits the use of an external power source for cold weather starting and during maintenance work on the airplane electrical system. Details of the ground power receptacle are presented in Section 9 "Supplements".

IFR AND NIGHT VFR ELECTRICAL SYSTEMS (if installed)

See Section 9 "Supplements".

LIGHTING SYSTEMS

EXTERIOR LIGHTING

■ Pre-MOD.151

Basic exterior lighting consists of conventional navigation lights located on the wing tips and tail cone, a landing light and a taxi light mounted on the L.H. wing leading edge.

The airplane may be equipped with an anticollision assembly, including a light on each wing tip and, as a replacement for the navigation light at the tail cone end, if required, with a double-function light (navigation light/strobe light).

■ Post-MOD.151

Basic exterior lighting consists of :

- a unit located on each wing tip including side and rear navigation lights, as well as an anticollision light,
- a landing light and a taxi light installed in the L.H. wing leading edge.

The airplane may be equipped, on each wing tip, with a recognition light.

■ All

In addition to the navigation lights, the exterior lighting may include a strobe light installed on the vertical stabilizer and under the fuselage.

Lighting controls :

The switch-breakers, located on the central pedestal front part (see Figure 7.5B), control the lighting of the landing and taxi lights, the navigation lights and anticollision lights.

NOTE :

The amperage of the wing tip anticollision light switch-breaker is increased when the airplane is equipped with the tail cone strobe light.

A switch, located on the circuit breaker panel (see Figure 7.6), controls the strobe light illumination. This circuit is protected by a circuit breaker located on the left of the switch.

- Anticollision lights and strobe lights should not be used when flying through clouds or overcast, the flashing light reflected from water droplets or particles in the atmosphere, particularly at night, can produce vertigo and loss of orientation.

INTERIOR LIGHTING

Instrument panel and control panels lighting is provided by integral, flood, post lights and electroluminescent lighting. Three lighting control knobs are grouped together on the L.H. part of the L.H. instrument panel.

- These three controls vary the intensity of all instrument panel and L.H. sidewall circuit breakers panel lightings, except for the rear overhead light. The following paragraphs describe the function of these controls.

Lighting controls :

They allow the operating from down to up of :

- "Normal" control which controls and modulates L.H. and R.H. instrument panels visors lighting.
- "Emergency" control Pre-MOD.151 :
which modulates lighting of overhead lights controlled by rotating them.
- "Emergency" control Post-MOD.151 :
which controls and modulates lighting of front overhead lights.
- "Radio and instruments" control which controls and modulates console visor lighting, instruments and equipment on instrument panel, emergency landing gear control and circuit breakers panel.

NOTE :

- *Both "normal" and "radio and instruments" controls and, Post-MOD.151, the emergency control operate and modulate lighting ; from high position "OFF", turn clockwise for "FULL INTENSITY OPERATION" then still clockwise, modulate towards "MINIMUM INTENSITY", turn back to "OFF" position turning counterclockwise.*
- *"Emergency" control, Pre-MOD.151, modulates lighting ; from high position "FULL INTENSITY" turn clockwise to modulate towards "MINIMUM INTENSITY" ; turn back to high position "FULL INTENSITY" turning counterclockwise .*

A courtesy light is installed in the cabin headliner, in front of the air outlets, to facilitate boarding or deplaning the airplane during night operations. The light circuit requires power to be applied to the main electrical system bus bars for operation (Main switch may remain OFF) .

This light is controlled by a toggle switch integrated to the light.

A maps reading light may be installed on the bottom of the control's wheel. This light illuminates the lower portion of the cabin in front of the pilot and is used for reading maps and other flight data during night operation. It is controlled by a switch located on the right horn of the pilot's control wheel.

DEMISTING, AIR REGULATION, VENTILATION, FIRE CUT-OFF

The temperature and air flow to the cabin are regulated by the cabin air regulation system and the air outlets (see Figure 7.18).

DEMISTING

The air intake located on the L.H. side of the propeller cone provides air supply to the exchanger located around the exhaust duct, the heated air supplies a box located on the upper portion of the aft face of the firewall. This box may be shut off by a fire cut-off shutter and allows hot air distribution on both sides of the windshield.

Hot airflow is regulated from the control panel located on R.H. side of instrument panel strip.

AIR REGULATION

Hot air

Comes from the exchanger (located around exhaust duct).

This heated air supplies a cabin air mixer located aft of the firewall (in front of front passenger's feet).

The hot airflow supplying this mixer is regulated by a fire cut-off shutter from the control panel located on R.H. portion of the instrument panel strip.

Cool air

Comes from R.H. NACA air intake. This cool air supplies cabin air mixer.

Hot/cool air mixing in cabin air mixer

Hot and cool airflows in cabin air mixer are actuated through a single control. Regulation is obtained by moving the control ; rightwards air becomes warmer, leftwards air becomes cooler, fully moved to the left in fire cut-off position for the cabin air mixer.

Distribution of regulated air

The mixed airflow in the cabin air mixer is regulated by a shutter before being distributed in the cabin towards pilot's feet, front and rear passengers' feet and in upper part of rear seat back-rest.

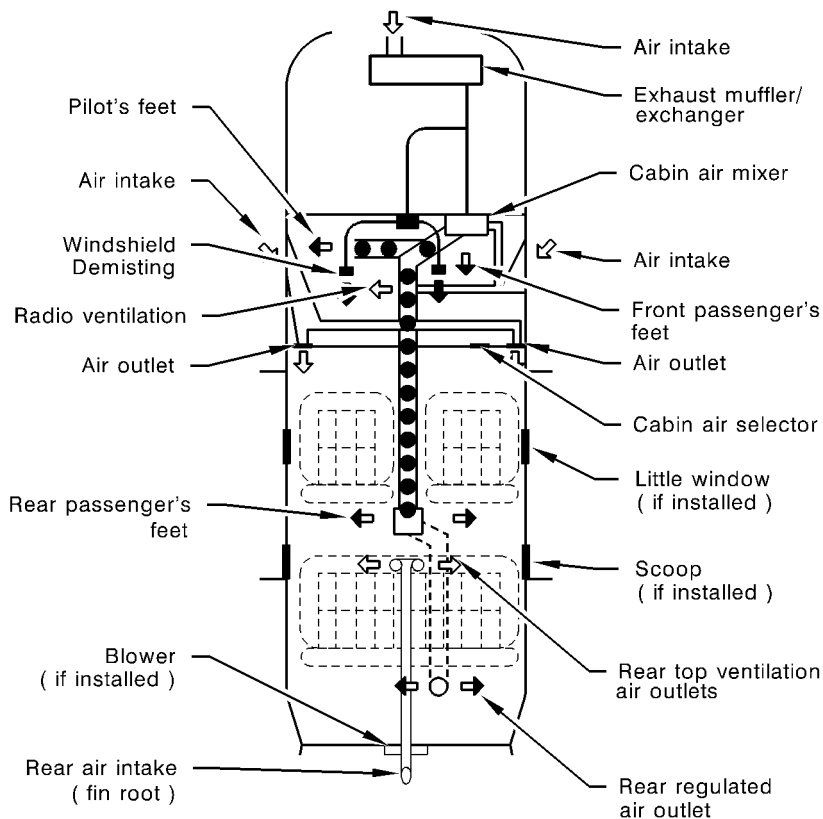

Key

- ◀ ◻ Cold air
- ◀ ◼ Hot air
- ◀ ◐ Regulated air

Cabin air selector

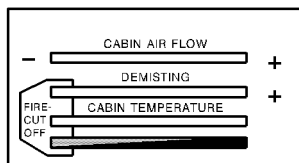

Figure 7.18 - DEMISTING, AIR REGULATION, VENTILATION, CUT-OFF SYSTEM

14210000AAACEY28100

VENTILATION

Low ventilation

See "Cold air" and "Distribution of regulated air" of the previous "AIR REGULATION" paragraph.

High ventilation

- Pilot + front passenger

Air (at outside temperature) coming from NACA L.H. air intake supplies two swivelling air outlets which airflow may be regulated, located on both parts of the instrument panel strip.

A little window may be installed on the access doors to facilitate high ventilation for pilot and front passenger.

- Rear passengers

An air intake (at outside temperature), located at the bottom part of the fin, supplies two air outlets (swivelling and which airflow may be regulated) installed on the upper duct.

A swivelling scoop may be installed on rear windows to facilitate high ventilation for rear passengers.

A blower (if installed) attached on aft face of the baggage compartment (former 6) and picking up outside air in aft fuselage permits to accelerate the cold airflow at rear seats. The blower switch is located on the upper duct, in front of air outlets (see Figure 7.4).

FIRE CUT-OFF

CAUTION

TO PROVIDE THE CUT-OFF OPERATION, BOTH "DEMISTING" AND "CABIN TEMPERATURE" CONTROLS MUST BE POSITIONED FULLY TO THE LEFT

AIRSPPEED INDICATING SYSTEM AND INSTRUMENTS

The airspeed indicating system (see Figure 7.19) supplies pitot air pressure to the airspeed indicator or to the true airspeed indicator and a static air pressure to the airspeed indicator or to the true airspeed indicator, the vertical speed indicator and the altimeter.

The system consists of a pitot, which can be heated, located on the lower surface of the L.H. wing, two static ports located on L.H. and R.H. side of aft fuselage, a static system drain located on the wings splicing.

The pitot heating system (if installed) is controlled by a switch-breaker located on the central pedestal.

The alternate static source (if installed) is controlled by a knob located on the L.H. strip, this knob controls a valve which supplies static pressure from inside the cabin.

Refer to Sections 3 "Emergency procedures" and 5 "Performance" of this manual for the pressure variations influence on instruments indication.

When stopped, protect the static ports and pitot with covers.

TRUE AIRSPPEED INDICATOR (if installed)

The true airspeed indicator is fitted with a rotatable ring which works in conjunction with its dial in a manner similar to a flight computer.

To set the indicator, first rotate the ring until pressure altitude is aligned with outside air temperature.

To obtain pressure altitude, set the barometric scale of the altimeter to 29.92 in.Hg (1013.2 hPa) and read pressure altitude. Pressure altitude should not be confused with QNH altitude.

Having set the ring to correct for altitude and temperature, read the true airspeed shown on the rotatable ring by the indicator pointer.

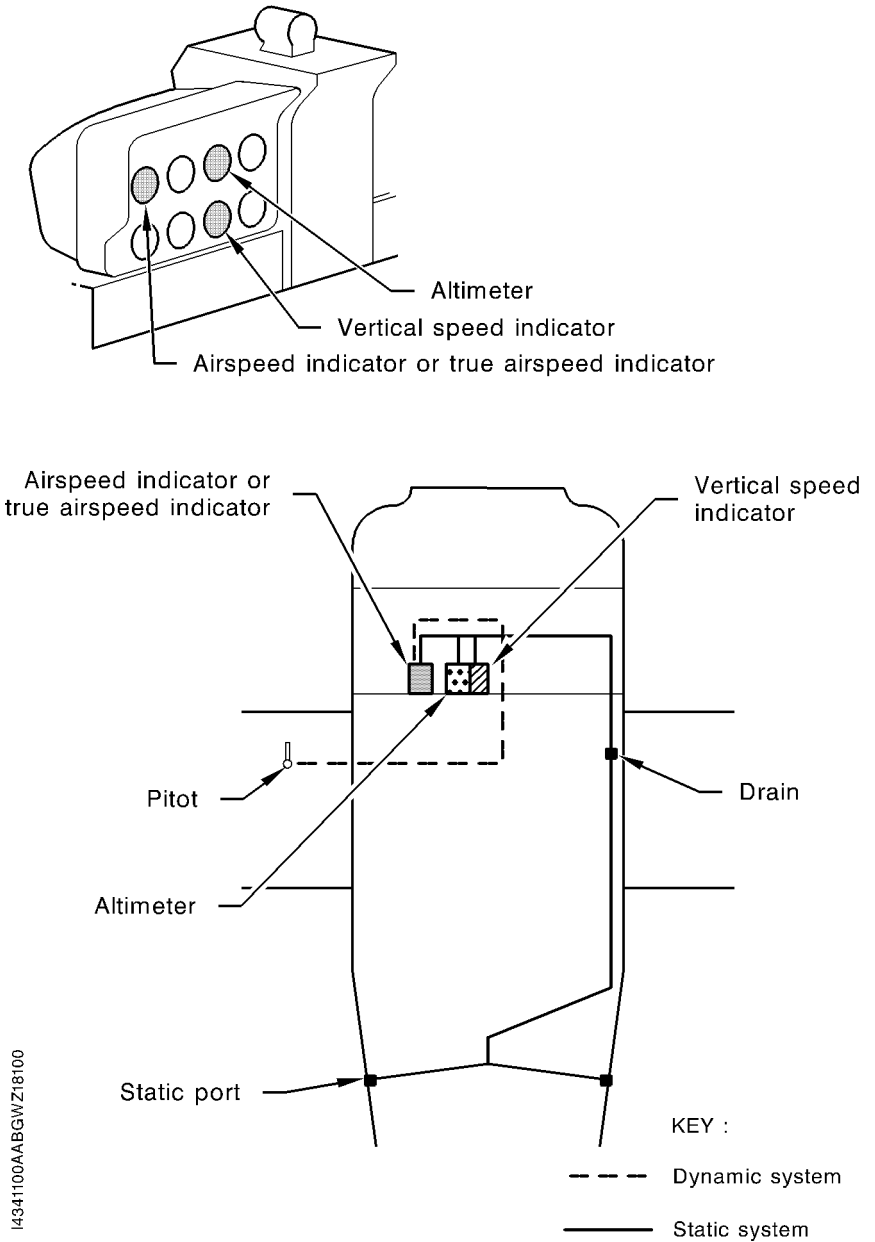

I4341100AABGWZ18100

Figure 7.19 - AIRSPEED INDICATING SYSTEM

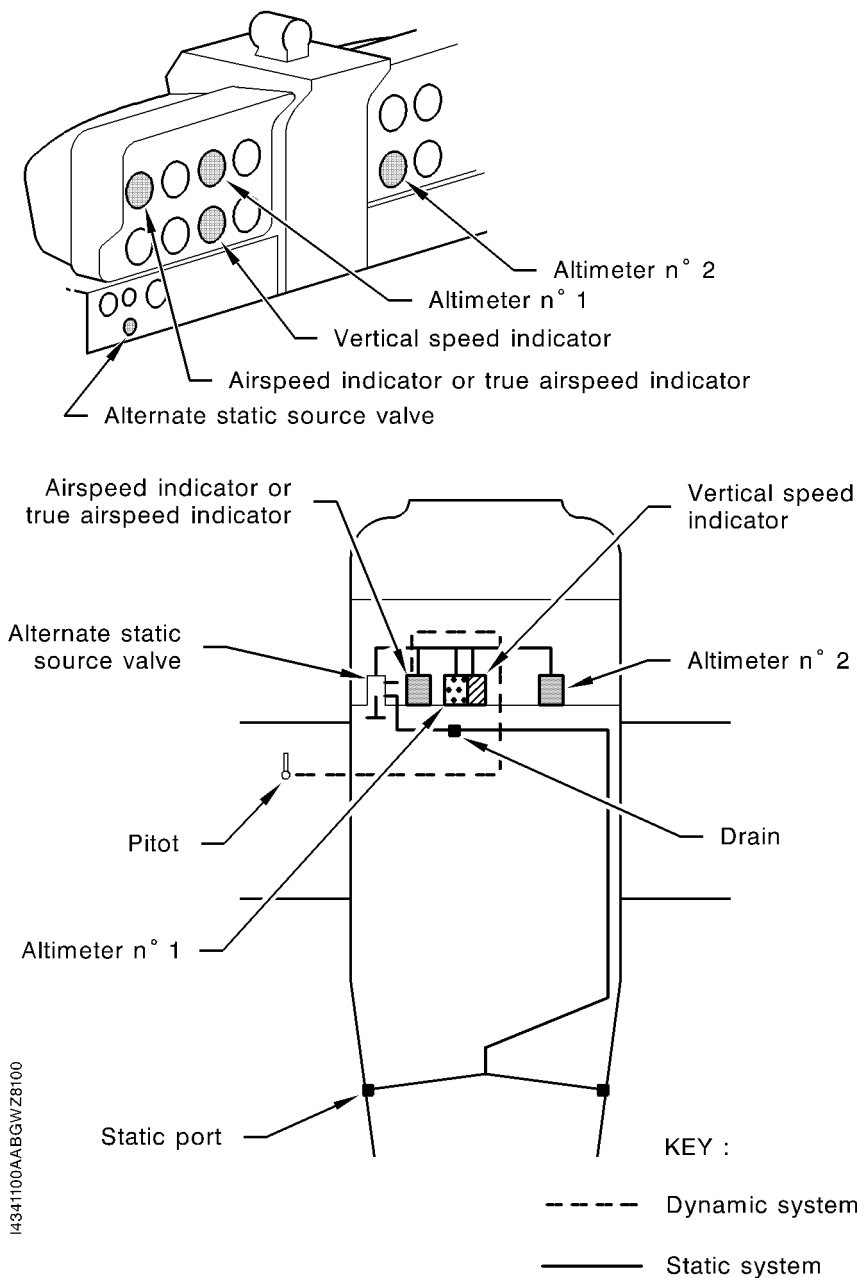

I4341100AABGWZ8100

Figure 7.19A - AIRSPEED INDICATING SYSTEM WITH ALTERNATE STATIC SOURCE

VERTICAL SPEED INDICATOR

The vertical speed indicator depicts airplane rate of climb or descent in feet per minute. The pointer is actuated by atmospheric pressure changes resulting from changes of altitude as supplied by the static source.

ALTIMETER

Airplane altitude is depicted by a barometric type altimeter. A knob near the lower left portion of the indicator provides adjustment of the instrument barometric scale to the current altimeter setting.

ALTERNATE STATIC SOURCE (if installed)

A two position selector allows the normal static source system of the airplane to be isolated in case of clogging or icing of static ports.

The ON position ("PULL") of the alternate static source valve admits cabin static pressure to the static system (see Figure 7.19A).

VACUUM SYSTEM AND INSTRUMENTS

The airplane may be fitted with a vacuum system (see Figures 7.20 and 7.20A) providing the suction necessary to operate an attitude gyro indicator and heading indicator.

The system consists of an engine-driven vacuum system, a vacuum relief valve and an air filter installed between the firewall and instrument panel, vacuum-operated instruments installed on L.H. instrument panel and a vacuum gage installed on L.H. panel strip, near the pilot's control wheel.

The system may be provided with an alarm, red warning light labelled "GYRO SUCT" on the advisory panel ; this warning light indicating an insufficient suction illuminates between 3 and 3.5 in.Hg.

ATTITUDE GYRO INDICATOR (if installed)

The attitude gyro indicator gives a visual indication of flight attitude. Bank attitude is presented by an index at the top of the indicator relative to the bank scale which has index marks at 10°, 20°, 30°, 60° and 90° either side of the center mark.

Pitch and roll attitudes are presented by a miniature airplane superimposed over a symbolic horizon area divided into two sections by a white horizon bar. The upper "sky blue" area and the lower "ground" area have arbitrary pitch reference lines useful for pitch attitude control.

A knob at the bottom of the instrument is provided for inflight adjustment of the miniature airplane to the horizon bar for a more accurate flight attitude indication.

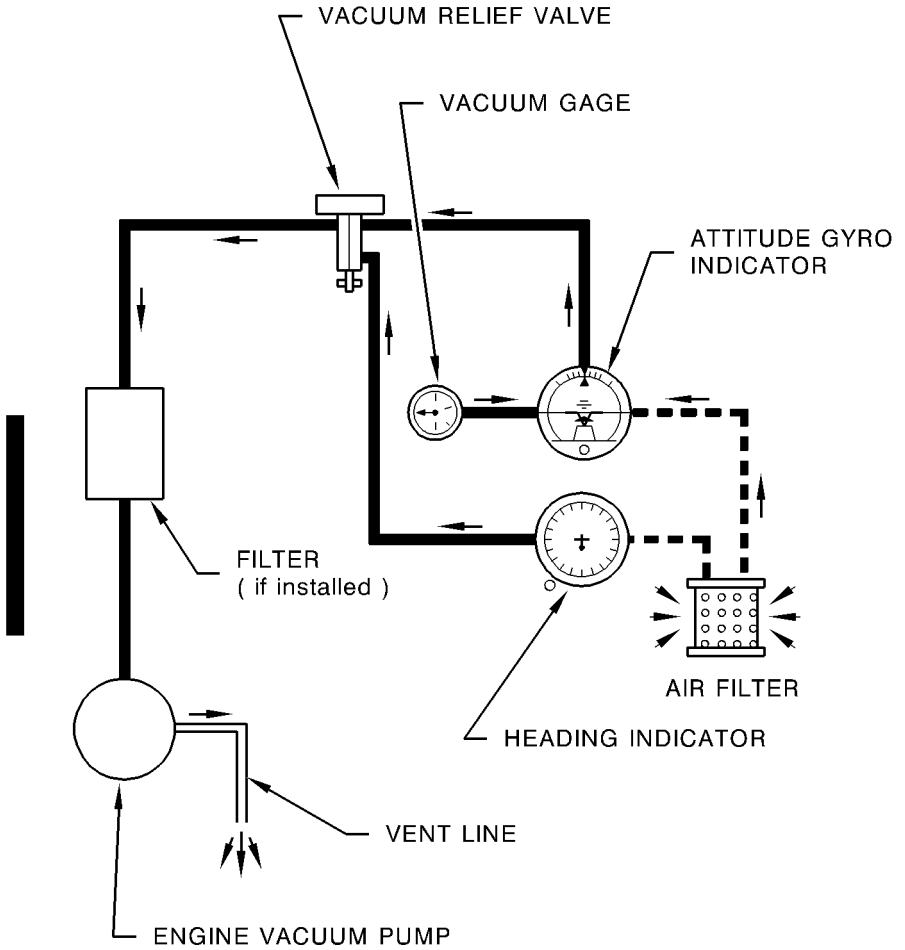

1437000AAA0VZ8100

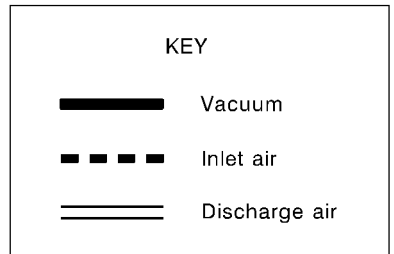
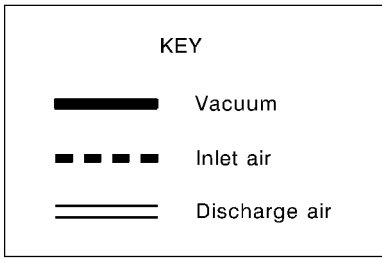
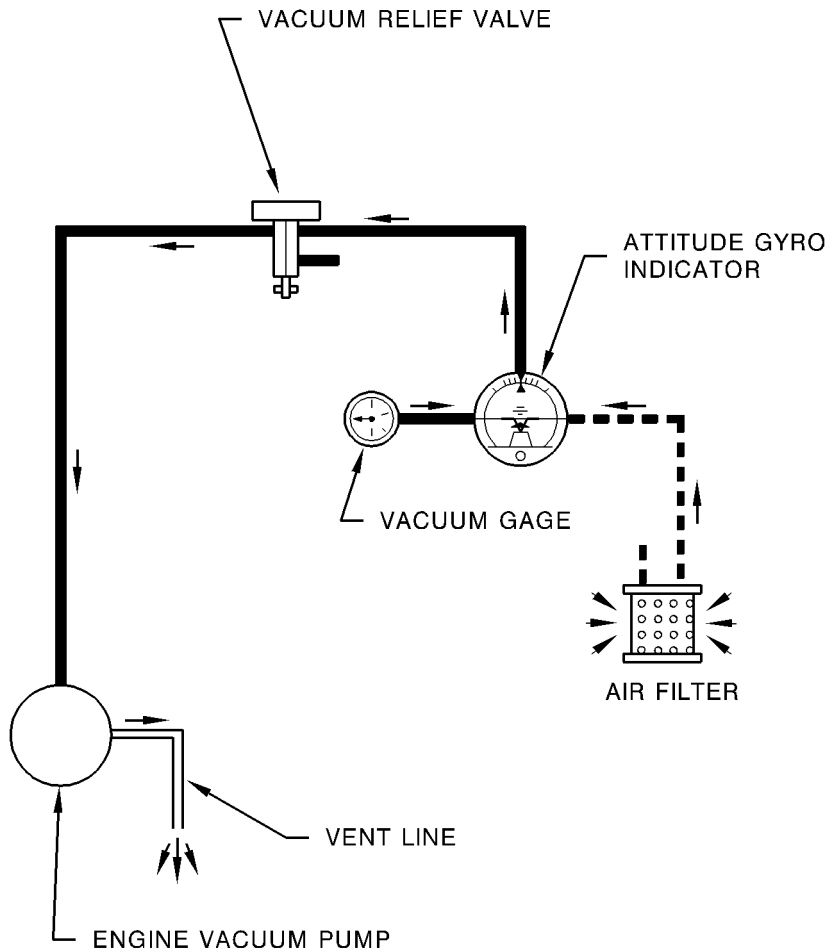

Figure 7.20 - VACUUM SYSTEM (With heading indicator)



I437000AAA0VZ18100

Figure 7.20A - VACUUM SYSTEM (Without heading indicator)

HEADING INDICATOR (if installed)

The heading indicator displays airplane heading on a compass card in relation to a fixed simulated airplane image and index. The directional indicator will precess slightly over a period of time. Therefore, the compass card should be set in accordance with the magnetic compass just prior to take-off and regularly re-adjusted on extended flights. A knob on the lower left edge of the instrument is used to adjust the compass card to correct for any precession.

VACUUM GAGE (if installed)

The vacuum gage is calibrated in inches of mercury and indicates the suction available for operation of the attitude and heading indicators. The desired suction range is 4.4 to 5.2 in.Hg.

A suction reading out of this range may indicate a system malfunction or improper adjustment, and in this case, the indicators should not be considered reliable.

AUXILIARY DRY AIR PUMP (if installed)

Refer to Section 9 "Supplements".

AUTOPILOTS

Refer to Section 9 "Supplements".

STALL WARNING SYSTEM

The airplane is equipped with a vane-type stall warning unit in the leading edge of the left wing. The unit is electrically connected to an aural warning. The vane in the wing senses the change in airflow over the wing and operates the warning unit, which produces a discontinuous tone on the buzzer located on the upper duct. This warning tone begins between 5 and 10 knots above the stall in all configurations.

The stall warning system should be checked during the preflight inspection by momentarily turning on the battery switch and actuating the vane in the wing. The system is operational if a discontinuous bell of the buzzer is heard.

STATIC DISCHARGERS (if installed)

As an aid in IFR flights, wick-type static dischargers are installed to improve radio communications during flight through dust or various forms of precipitation (rain, snow or ice crystals).

Under these conditions, the build-up and discharge of static electricity from the trailing edges of the wings (flaps and ailerons), rudder, stabilator, propeller tips and radio antennas can result in loss of usable radio signals on all communications and navigation radio equipment. Usually, the ADF is first to be affected and VHF communication equipment is the last to be affected.

Installation of static dischargers reduces interference from precipitation static, but it is possible to encounter severe precipitation static conditions which might cause the loss of radio signals, even with static dischargers installed. Whenever possible, avoid known severe precipitation areas to prevent loss of dependable radio signals. If avoidance is impractical, minimize airspeed and anticipate temporary loss of radio signals while in these areas.

RADIO EQUIPMENT

Refer to Section 9 "Supplements".

TURN-AND-BANK INDICATOR (if installed)

The bank indicator located under the airspeed indicator or the true airspeed indicator may be replaced by a turn and bank indicator ; it is controlled by a switch-breaker located in front of the pedestal and labeled "TURN COORD."

CLEAR-VISION WINDOW (if installed)

In case a lot of mist appears on the windshield, turn both clear-vision window attachment knobs upwards and tilt window downwards.

NOTE :

Close the clear-vision window and lock it with both knobs prior to opening "gull-wing" access door.

SUN VISOR (if installed)

To remove sun visor, firmly pull downwards the foamed attachment pin.

Up to S / N 1115, the attachment pin is equipped (in its upper part) with an adjusting screw which provides friction on arm swivelling. After adjustment, lock the screw using varnish.

From S / N 1116, an adjusting knurled knob located under the attachment pin stiffens sun visor arm rotation without removing the pin.

To reinstall the sun visor, hit it firmly upwards, at the base of the foamed attachment pin.

FIRE EXTINGUISHER (if installed)

The fire extinguisher is located under L.H. front seat. It is accessible by moving the seat full backwards. It is attached on the floor by means of a quick-disconnect clamp. A pressure gage allows checking the fire extinguisher condition, follow the recommendations indicated on the extinguisher.

EMERGENCY LOCATOR TRANSMITTER (if installed)

The airplane may be equipped with an emergency locator transmitter, which enables to locate it in case of distress. It is located in the baggage compartment.

The emergency locator transmitter assembly is constituted of a transmitter supplied by a battery, of a retractable antenna integrated in the locator transmitter and allowing use of the latter outside the airplane and of a remote control located on the instrument panel.

Operation of the emergency locator transmitter is obtained as follows :

- from the instrument panel by setting "ELT" remote control switch to ON or MAN position (locator transmitter "MANU-OFF-AUTO" or "MAN/RESET-OFF-AUTO" control switch in stand-by on AUTO position),
- from the locator transmitter by setting its "MANU-OFF-AUTO" or "MAN/RESET-OFF-AUTO" control switch to MANU or MAN/RESET position,
- automatically in case of shock, when both switches are set to AUTO.

When locator transmitter "MANU-OFF-AUTO" or "MAN/RESET-OFF-AUTO" switch is set to OFF, transmission is impossible.

"XMIT ALERT" indicator light (if installed) located above "ELT" remote control switch indicates to the pilot the emergency locator transmitter is transmitting.

Reset after an inadvertent activation

ELT 90 (EUROCAE) - ELT 91 (TSO)

- | | |
|---|---|
| 1) Set ELT switch to "MAN/RESET" or remote control switch to "MAN". | a) The ELT keeps on transmitting emergency signal.
b) On remote control, the "XMIT ALERT" red warning light remains on.
c) On ELT, the red warning light remains on. |
| 2) Set again ELT switch or remote control switch to "AUTO". | a) The ELT does not transmit emergency signal any longer.
b) On remote control, the "XMIT ALERT" red warning light goes off.
c) On ELT, the red warning light goes off. |

ELT 96 (EUROCAE) - ELT 97 (TSO)

- | | |
|--|--|
| 1) Set ELT switch to "MAN/RESET", then to "AUTO" or press push button "AUTO TEST/RESET" on the remote control. | a) The ELT does not transmit emergency signal any longer.
b) On remote control and on ELT switch, the "XMIT ALERT" red warning light illuminates during 2 seconds, then goes off. |
|--|--|

JE2, ELT 10 AND POINTER 3000

On ELT, press on button "RESET".

INTENTIONALLY LEFT BLANK

SECTION 8

AIRPLANE HANDLING, SERVICING AND MAINTENANCE

TABLE OF CONTENTS

	Page
GENERAL	8.3
IDENTIFICATION PLATE	8.3
PUBLICATIONS	8.4
INSPECTION PERIODS	8.4
ALTERATIONS OR REPAIRS	8.4
GROUND HANDLING	8.5
TOWING	8.5
PARKING	8.5
TIE-DOWN	8.7
JACKING	8.7
LEVELING	8.7
FLYABLE STORAGE	8.7
LONG TERM STORAGE WITHOUT FLYING POSSIBILITY	8.8
SERVICING	8.8
MAINTENANCE	8.8
ENGINE OIL	8.9
FUEL	8.11
LANDING GEAR	8.16

TABLE OF CONTENTS
(Continued)

	Page
AIRPLANE CLEANING AND CARE	8.17
WINDOWS AND WINDSHIELD	8.17
PAINTED SURFACES	8.17
PROPELLER CARE	8.18
ENGINE CARE	8.18
INTERIOR CARE	8.18
FRONT ASH-TRAY	8.18
REAR ASH-TRAYS	8.18

GENERAL

This section contains the procedures recommended by SOCATA for the proper ground handling and routine care and servicing of your SOCATA Model TB 10 airplane. Also included in this section are the inspection and maintenance requirements which must be followed if your airplane is to retain its performance and dependability.

It is recommended that a planned schedule of lubrication and preventive maintenance be followed, and that this schedule be tailored to the climatic or flying conditions to which the airplane is subjected.

For this, see Manufacturer's Maintenance Manual.

IDENTIFICATION PLATE

All correspondence regarding your airplane should include its serial number. This number together with the model number, type certificate number and production certificate number are stamped on the identification plate attached to the rear part of the fuselage beneath the horizontal stabilizer.

PUBLICATIONS

When the airplane is delivered from the factory, it is supplied with a Pilot's Operating Handbook and supplemental data covering optional equipment installed in the airplane.

In addition, the owner may purchase the following :

- Maintenance Manual
- Illustrated Parts Catalog
- Price Catalog
- Labor Allowance Guide

CAUTION

**PILOT'S OPERATING HANDBOOK MUST ALWAYS
BE IN THE AIRPLANE**

INSPECTION PERIODS

Refer to regulations in force in the certification country for information concerning preventive maintenance which is to be carried out by pilots.

A maintenance Manual should be obtained prior to performing any preventive maintenance to ensure that proper procedures are followed. Maintenance must be accomplished by licensed personnel.

ALTERATIONS OR REPAIRS

It is essential that the Airworthiness authorities be contacted prior to any alterations or repairs on the airplane to ensure that airworthiness of the airplane is not violated. Alterations or repairs must be accomplished by licensed personnel.

GROUND HANDLING

TOWING

CAUTION

USING THE PROPELLER FOR GROUND HANDLING COULD RESULT IN SERIOUS DAMAGE, ESPECIALLY IF PRESSURE OR PULL IS EXERTED ON BLADE TIPS

The airplane should be moved on the ground with the aid of nose gear strut fork tow bar which is stowed in the baggage compartment or with a vehicle which will not damage the nose gear steering device or exert excessive loads on the latter.

CAUTION

DO NOT TOW THE AIRPLANE WHEN CONTROLS ARE LOCKED

WHEN TOWING WITH A VEHICLE, DO NOT EXCEED THE NOSE GEAR TURNING ANGLE, OR DAMAGE TO THE GEAR AND STEERING DEVICE WILL RESULT

(see Figure 8.2)

PARKING

When parking the airplane, head into the wind. Do not set the parking brake when brakes are overheated or during cold weather when accumulated moisture may freeze the brakes. Care should be taken when using the parking brake for an extended period of time during which an air temperature rise or drop could cause difficulty in releasing the parking brake or damage the brake system.

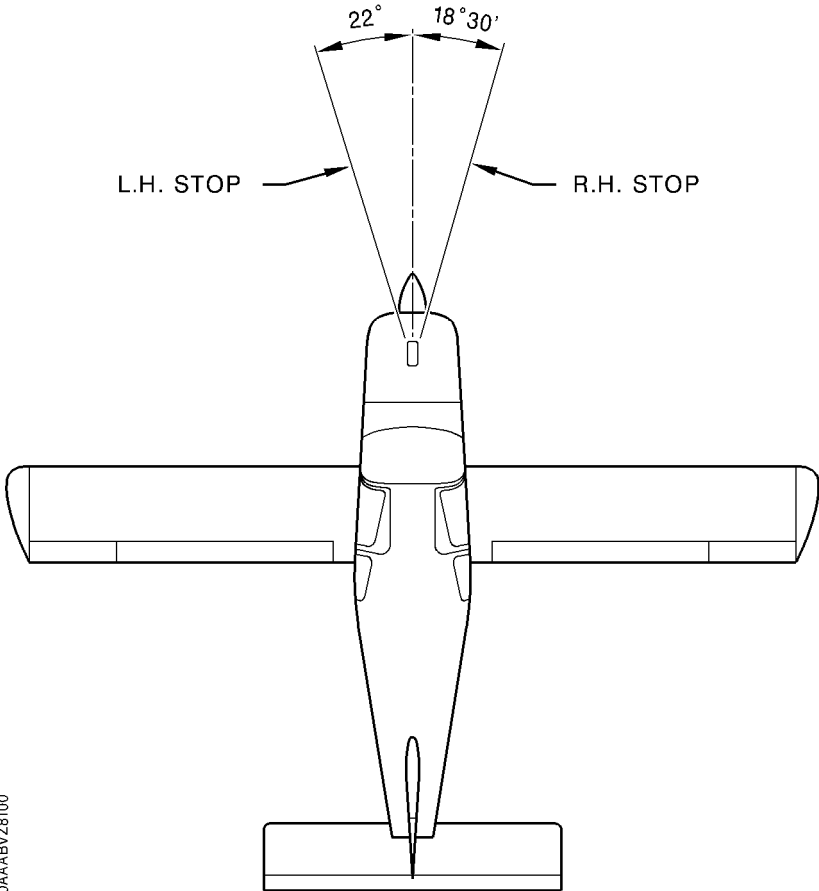

14062000AAAABVZ8100

Figure 8.2 - TURNING ANGLE LIMITS

For long term parking, blanking covers (static ports, pitot), cockpit cover, tie-downs, wheel chocks and control wheel lock are recommended. In severe weather and high wind conditions, tie the airplane down as outlined in the following paragraph.

TIE-DOWN

Proper tie-down procedure is the best protection against damage to the parked airplane by gusty or strong winds. To tie-down the airplane securely, proceed as follows :

- Install control wheel lock.
- Chock all wheels.
- Tie sufficiently strong ropes or chains to hold airplane back ; insert a rope in each tie-down hole located on flaps hinge arms and in rear tie-down fitting, located under horizontal stabilizer ; secure each rope to a ramp tie-down.
- Check that doors are closed and locked.

JACKING

When it is necessary to jack the airplane off the ground or when jacking points are used, refer to Maintenance Manual for specific procedures and equipment required.

LEVELING

Level the airplane as described in Maintenance Manual.

FLYABLE STORAGE

Airplanes placed in storage for a maximum of 30 days or those which receive only intermittent use for the first 25 hours are considered in flyable storage.

Every seventh day during these periods, the propeller should be rotated by hand through several revolutions. This action "limbers" the oil and prevents any accumulation of corrosion on engine cylinder walls.

CAUTION

CHECK THAT THE MAGNETO SELECTOR IS OFF, THE THROTTLE IS CLOSED, THE MIXTURE CONTROL IS IN THE IDLE CUT-OFF POSITION, AND THE AIRPLANE IS SECURED BEFORE ROTATING THE PROPELLER BY HAND. DO NOT STAND WITHIN THE ARC OF THE PROPELLER BLADES WHILE TURNING THE PROPELLER

After 30 days in storage, the airplane should be flown for at least 30 minutes, or a ground runup should be made just long enough to produce an oil temperature within the lower green arc range. Avoid prolonged runups.

Engine runup helps to eliminate excessive accumulations of water in the fuel system and other air spaces in the engine. Keep fuel tanks full to minimize condensation in the tanks. Keep the battery fully charged to prevent the electrolyte from freezing in cold weather.

LONG TERM STORAGE WITHOUT FLYING POSSIBILITY

Refer to Maintenance Manual for the procedures to follow.

SERVICING

MAINTENANCE

In addition to the preflight inspection in Section 4, servicing, inspection, and test requirements for your airplane are detailed in the Maintenance Manual.

Maintenance Manual outlines all items which require attention at 50, 100, 400, 500 and 1000 hours intervals plus those items which require servicing, inspection or testing at special intervals, first 25 flight hours, yearly inspection, major inspection.

ENGINE OIL

CAUTION

DO NOT MIX DIFFERENT BRANDS OR TYPES OF OIL

Grade and Viscosity for temperature range (Reference : TEXTRON LYCOMING Service Bulletin No. 480 at last revision) :

Outside Air Temperature	MIL-L-6082 Spec. Mineral Grades 50 first hours	MIL-L-22851 Spec. Dispersant Grades after 50 hours
All temperatures	SAE 15W50 or 20W50
Above 80°F (27°C)	SAE 60	SAE 60
Above 60°F (15°C)	SAE 50	SAE 40 or SAE 50
30°F (-1°C) to 90°F (32°C)	SAE 40	SAE 40
0°F (-18°C) to 70°F (21°C)	SAE 30	SAE 30, SAE 40 or SAE 20W40
0°F (-18°C) to 90°F (32°C)	SAE 20W50 or 15W50
Under 10°F (-12°C)	SAE 20	SAE 30 or SAE 20W30

NOTE :

This airplane was delivered from the factory with a corrosion-preventive aircraft engine oil. If oil must be added during the first 50 hours, use only aviation grade straight mineral oil conforming to specification MIL-L-6082.

Capacity of engine sump : 8 U.S. qt (7.6 litres)

Do not operate on less than 4 U.S. qt (3.8 litres). To minimize loss of oil through breather, fill to 6 U.S. qt (5.7 litres) for normal flights of less than 3 hours. For extended flights, fill to 8 U.S. qt (7.6 litres). These quantities refer to oil dipstick level readings. During oil and filter changes 0.45 additional U.S. qt (0.4 litres) is required for the filter.

Oil and oil filter change :

In addition to the preflight inspection in Section 4, servicing, inspection, and test requirements for your airplane are detailed in the Maintenance Manual.

Engine oil is changed with the filter. Drain the engine oil sump and replace the filter at least every 4 months even though less than the recommended hours have accumulated. Reduce intervals for prolonged operation in dusty areas, cold climates, or even when short flights and long idle periods result in sludging conditions.

FUEL

Approved fuel grades (and colors)

100 LL Grade Aviation Fuel (Blue)

100 Grade Aviation Fuel (Formerly 100 / 130) (Green).

CAUTION

NEVER FLY THE AIRPLANE WITH CONTAMINATED (WATER, SAND, RUST, DUST...) OR UNAPPROVED FUEL

NOTE :

Isopropyl alcohol or ethylene glycol monomethyl ether may be added to the fuel supply in quantities not to exceed 1 % or 0.15 % by volume, respectively, of the total. Refer to "Fuel Additives" paragraph hereafter for additional information.

Capacity each tank : 27.7 U.S Gal (105 l)

NOTE :

Service the fuel system after each flight and keep fuel tanks full to minimize condensation in the tanks, respecting weight and balance limits.

WARNING

DO NOT OPERATE ANY AVIONICS OR ELECTRICAL EQUIPMENT ON THE AIRPLANE DURING FUELING. DO NOT ALLOW OPEN FLAME OR SMOKING IN THE VICINITY OF THE AIRPLANE WHILE FUELING

DURING ALL FUELING OPERATIONS, FIRE FIGHTING EQUIPMENT MUST BE AVAILABLE ; ATTACH GROUNDING WIRE TO ANGLE (IF INSTALLED) ON UPPER SURFACE OF WING NEAR THE CAP ; IN CASE THERE IS NO ANGLE, ATTACH CABLE TO A METALLIC PART OF THE AIRPLANE WHICH IS NOT PAINTED

Fuel additives

Strict adherence to recommended preflight draining instructions as called for in Section 4 will eliminate any free water accumulations from the tank sumps. While small amounts of water may still remain in solution in the gasoline, it will normally be consumed and go unnoticed in the operation of the engine.

One exception to this can be encountered when operating under the combined effect of use of certain fuels, with high humidity conditions on the ground followed by flight at high altitude and low temperature. Under these unusual conditions, small amounts of water in solution can precipitate from the fuel stream and freeze in sufficient quantities to induce partial icing of the engine fuel system.

While these conditions are quite rare and will not normally pose a problem to owners and operators, they do exist in certain areas of the world and consequently must be dealt with, when encountered.

Therefore, to alleviate the possibility of fuel icing occurring under these unusual conditions, it is permissible to add isopropyl alcohol or ethylene glycol monomethyl ether (EGME) compound to the fuel supply.

The introduction of alcohol or EGME compound into the fuel provides two distinct effects :

- it absorbs the dissolved water from the fuel
- alcohol has a freezing temperature lowering effect.

Alcohol, if used, is to be mixed with the fuel in a concentration of 1 % by volume. Concentrations greater than 1 % are not recommended since they can be detrimental to fuel tank materials.

The manner in which the alcohol is added to the fuel is significant because alcohol is most effective when it is completely dissolved in the fuel.

To ensure proper mixing, the following is recommended :

- For best results, the alcohol should be added during the fueling operation by pouring the alcohol directly on the fuel stream issuing from the fueling nozzle.
- An alternate method that may be used is to premix the complete alcohol dosage with some fuel in a separate clean container (approximately 2 to 3 U.S Gal - 7 to 11 litres) and then transferring this mixture to the tank prior to the fueling operation.

Any high quality isopropyl alcohol may be used, such as anti-icing fluid or isopropyl alcohol (Federal Specification TT-I-735a). Figure 8.3 provides alcohol - fuel mixing ratio information.

Ethylene glycol monomethyl ether (EGME) compounds, in compliance with MIL-I-27686, if used, must be carefully mixed with the fuel in concentration not to exceed 0.15 % by volume. Figure 8.3 provides EGME - fuel mixing ratio information.

CAUTION

MIXING OF THE EGME COMPOUND WITH THE FUEL IS EXTREMELY IMPORTANT. A CONCENTRATION IN EXCESS OF THAT RECOMMENDED (0.15 % BY VOLUME MAXIMUM) WILL RESULT IN DETRIMENTAL EFFECTS TO THE FUEL TANKS (DETERIORATION OF PROTECTIVE PRIMER AND SEALANTS) TO FUEL SYSTEM AND ENGINE COMPONENTS (DAMAGE TO SEALS). USE ONLY BLENDING EQUIPMENT RECOMMENDED BY THE MANUFACTURER TO OBTAIN PROPER PROPORTIONING

DO NOT ALLOW CONCENTRATED EGME COMPOUND TO COME IN CONTACT WITH THE AIRPLANE FINISH AS DAMAGE CAN RESULT

Prolonged storage of the airplane will result in a water buildup in the fuel which "leeches out" the additive. An indication of this is when an excessive amount of water accumulates in the fuel tank sumps. The concentration can be checked using a differential refractometer. It is imperative that the technical manual for the differential refractometer be followed explicitly when checking the additive concentration.

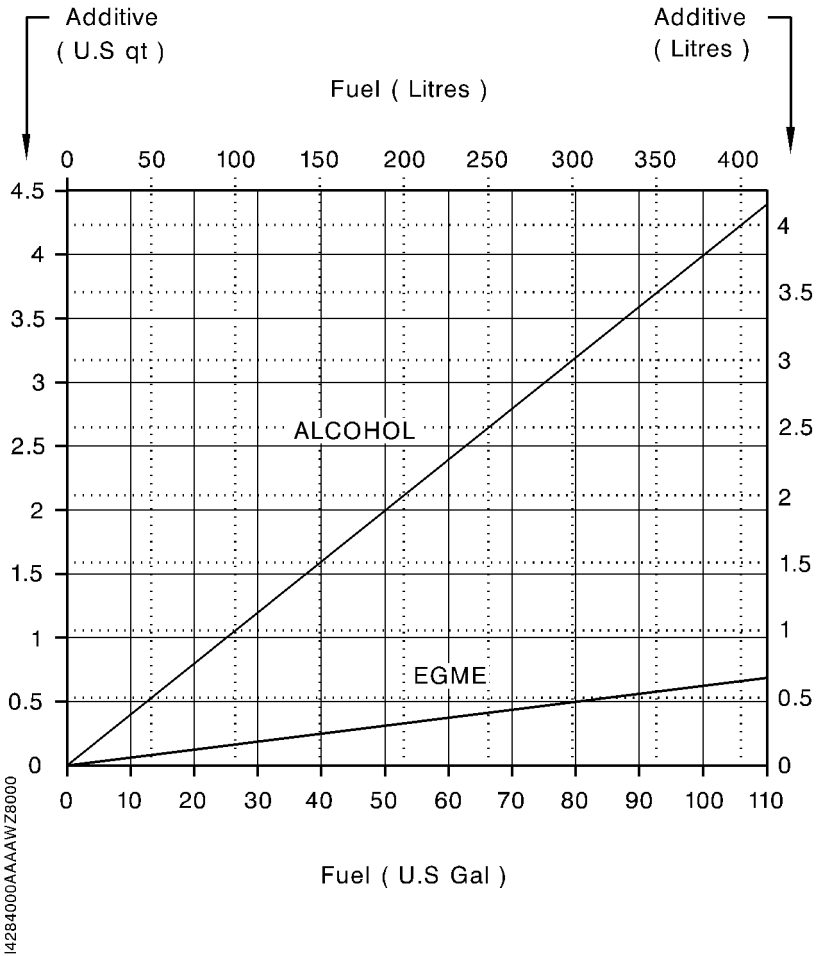

Figure 8.3 - ADDITIVE MIXING RATIO

LANDING GEAR

Nose gear tire :

5.00-5 6 PRTT - Inflating pressure : 44.9 psi (3.1 bars)

Main gear tires :

Aircraft not equipped with modification MOD. 118 or MOD. 120 :

Standard : 6.00-6 6 PRTT - Inflating pressure : 33.3 psi (2.3 bars)

Aircraft equipped with modification MOD. 118 or MOD. 120 :

6.00-6 6 PRTT - Inflating pressure : 40.6 psi (2.8 bars)

Nose gear shock absorber :

- Filling with hydraulic fluid MIL-H-5606 ; inflate with pressurized dry air or nitrogen to 98.6 psi (± 4) that is 6.8 bars (± 0.3).

Main gears shock absorbers :

Aircraft not equipped with modification MOD. 118 or MOD. 120 :

- Filling with hydraulic fluid MIL-H-5606 ; inflate with pressurized dry air or nitrogen to 130.5 psi (± 4) that is 9 bars (± 0.3).

Aircraft equipped with modification MOD. 118 or MOD. 120 :

- Filling with hydraulic fluid MIL-H-5606 ; inflate with pressurized dry air or nitrogen to 479 psi (+ 15 ; - 0) that is 33 bars (+ 1 ; - 0).

Brakes :

Service as required with MIL-H-5606 hydraulic fluid.

AIRPLANE CLEANING AND CARE

WINDOWS AND WINDSHIELD

The plastic windshield and windows should be cleaned with an airplane windshield cleaner. Apply the cleaner sparingly with soft cloths and rub with moderate pressure until all dirt, oil scum and bug stains are removed. Allow the cleaner to dry, then wipe it off with soft flannel cloths.

CAUTION

NEVER USE GASOLINE, BENZINE ALCOHOL, ACETONE, FIRE EXTINGUISHER OR ANTI-ICE FLUID, LACQUER THINNER OR GLASS CLEANER TO CLEAN THE PLASTIC. THESE MATERIALS WILL ATTACK THE PLASTIC AND MAY CAUSE IT TO CRAZE

Follow by carefully washing with a mild detergent and plenty of water. Rinse thoroughly, then dry with a clean moist chamois. Do not rub the plastic with a dry cloth since this builds up an electrostatic charge which attracts dust. Waxing with a good commercial wax will finish the cleaning job. A thin, even coat of wax polished out by hand with clean soft flannel cloths will fill in minor scratches and help prevent further scratching.

Do not use a canvas cover on the windshield unless freezing rain or sleet is anticipated since the cover may scratch the plastic surface.

PAINTED SURFACES

Refer to Maintenance Manual for the procedures to follow.

PROPELLER CARE

Preflight inspection of propeller blades for nicks and wiping them occasionally with an oily cloth to clean off grass and bug stains will assure long blade life. Small nicks on the propeller, particularly near the tips and on the leading edges, should be dressed out as soon as possible since these nicks produce stress concentrations, and if ignored, may result in cracks. Never use an alkaline cleaner on the blades ; remove grease and dirt.

ENGINE CARE

Refer to Maintenance Manual for the procedures to follow.

INTERIOR CARE

To remove dust and loose dirt from the upholstery and carpet, clean the interior regularly with a vacuum cleaner.

For additional information, refer to Maintenance Manual.

FRONT ASH-TRAY

To empty front ash-tray, remove it while holding it on its edges (if necessary, lift it up with a screwdriver wrapped up in a cloth.

REAR ASH-TRAYS

To empty a rear ash-tray, open it tilting its movable part to its stop, then push moderately on central part to disengage the ash-box.

To install again the ash-box, insert upper part then push on lower part.